



<i>Section</i>	<i>Page No.</i>
<b>INTRODUCTION</b>	<b>1</b>
<b>PURPOSE OF MACHINE</b>	<b>2</b>
<b>MACHINE DIMENSIONS &amp; SPECIFICATIONS</b>	<b>2</b>
<b>PARTS LOCATION DIAGRAMS</b>	<b>4</b>
<b>SAFE WORKING</b>	<b>6</b>
Operator's Personal Protective Equipment Required	6
Basic Shredding Safety	6
General Safety Matters - Do's and Dont's	7
Noise Test	8
<b>OPERATING INSTRUCTIONS</b>	<b>9</b>
Safe Transportation	9
Hitching onto the Tow Ball	9
Unhitching the Shredder	9
Stabilising the Shredder	9
Delivery	10
Operator's Personal Protective Equipment Required	10
Manual Controls	10
Auto Controls	11
Emergency Stopping	11
Hydraulic Oil Level Indicator	11
Fuel Level Indicator	11
Daily Checks Before Starting	11
Discharge Controls	11
Engine Controls - Diesel Models	12
Before Using the Shredder - Diesel Models	12
Starting the Engine - Diesel Models	12
Stopping the Engine - Diesel Models	12
Engine Controls - Petrol Models	13
Before Using the Shredder - Petrol Models	13
Starting the Engine - Petrol Models	13
Stopping the Engine - Petrol Models	13
Starting to Shred	14
Shredding	14
Blockages	14
<b>SERVICE INSTRUCTIONS</b>	<b>15</b>
Service Schedule	16
Safe Maintenance	17
Safe Lifting of the Shredder	17
Spares	17
Battery Removal and Maintenance	17
Check Fittings	17
Copper Ease Safety Information	18
Battery Safety Information	18
Change Hammers	19
Check for Free Rotation of Drum and Hammers	19
Servicing the Conveyor	21
Engine Servicing	21
Check Hoses	21
Tension Drive Belts	22
Change Hydraulic Oil and Filter	22
Grease the Discharge Flange	22
Grease the Roller Spline and Bearing	23
Grease the Roller Box Slides	23
Grease the Drum Bearings	23
<b>WARRANTY STATEMENT</b>	<b>24</b>
<b>EC DECLARATION OF CONFORMITY CERTIFICATES</b>	<b>25</b>
<b>IDENTIFICATION PLATE</b>	<b>27</b>
<b>DECALS</b>	<b>28</b>
<b>ELECTRICAL DETAILS</b>	<b>30</b>
<b>CIRCUIT DIAGRAMS</b>	<b>32</b>
<b>HYDRAULIC LAYOUT</b>	<b>34</b>
<b>PARTS LISTS</b>	<b>36</b>



# INTRODUCTION

Thank you for choosing this Timberwolf shredder. Timberwolf shredders are designed to give safe and dependable service if operated according to the instructions.

## IMPORTANT HEALTH AND SAFETY INFORMATION

Before using your new shredder, please take time to read this manual. Failure to do so could result in:

- PERSONAL INJURY
- EQUIPMENT DAMAGE
- DAMAGE TO PROPERTY
- 3RD PARTY INJURY

This manual covers the operation and maintenance of the Timberwolf TW SX200PHB/TW SX200PHB(c)/TW SX200DHB/TW SX200DHB(c). All information in this manual is based on the latest product information available at the time of purchase.

All the information you need to operate the machine safely and effectively is contained within pages 2 to 14. Ensure that all operators are **properly trained** for operating this machine, especially **safe working practices**.

Timberwolf's policy of regularly reviewing and improving their products may involve major or minor changes to the shredders or their accessories. Timberwolf reserves the right to make changes at any time without notice and without incurring any obligation.

Due to improvements in design and performance during production there may be (in some cases) minor discrepancies between the actual shredder and the text in this manual.

**The manual should be considered an important part of the machine and should remain with it if the machine is resold.**

***ALWAYS FOLLOW SAFE OPERATING AND MAINTENANCE PRACTICES***



## CAUTION or WARNING

***BE AWARE OF THIS SYMBOL AND WHERE SHOWN, CAREFULLY FOLLOW THE INSTRUCTIONS.***

This caution symbol indicates important safety messages in this manual. When you see this symbol, be alert to the possibility of injury to yourself or others and carefully read the message that follows.



## The Timberwolf TW SX200 - DIESEL MODELS

The Timberwolf SX200DHB(c) is a high speed, professional shredder. It is designed to shred general green waste (brush, general prunings, hedge trimmings, leylandii, Christmas trees, root balls, nursery waste (such as packaging, plastic plant pots/seed trays etc), gorse, black-thorn, laurel, privet and cotoneaster etc.

The maximum feed aperture opening is 150mm; the machine will handle solid brushwood up to a maximum diameter of 100mm.

The shredder mechanism is robust enough to tolerate medium levels of contamination such as dirt, small stones, tin cans, nails and other similar small items.

### DIMENSIONS

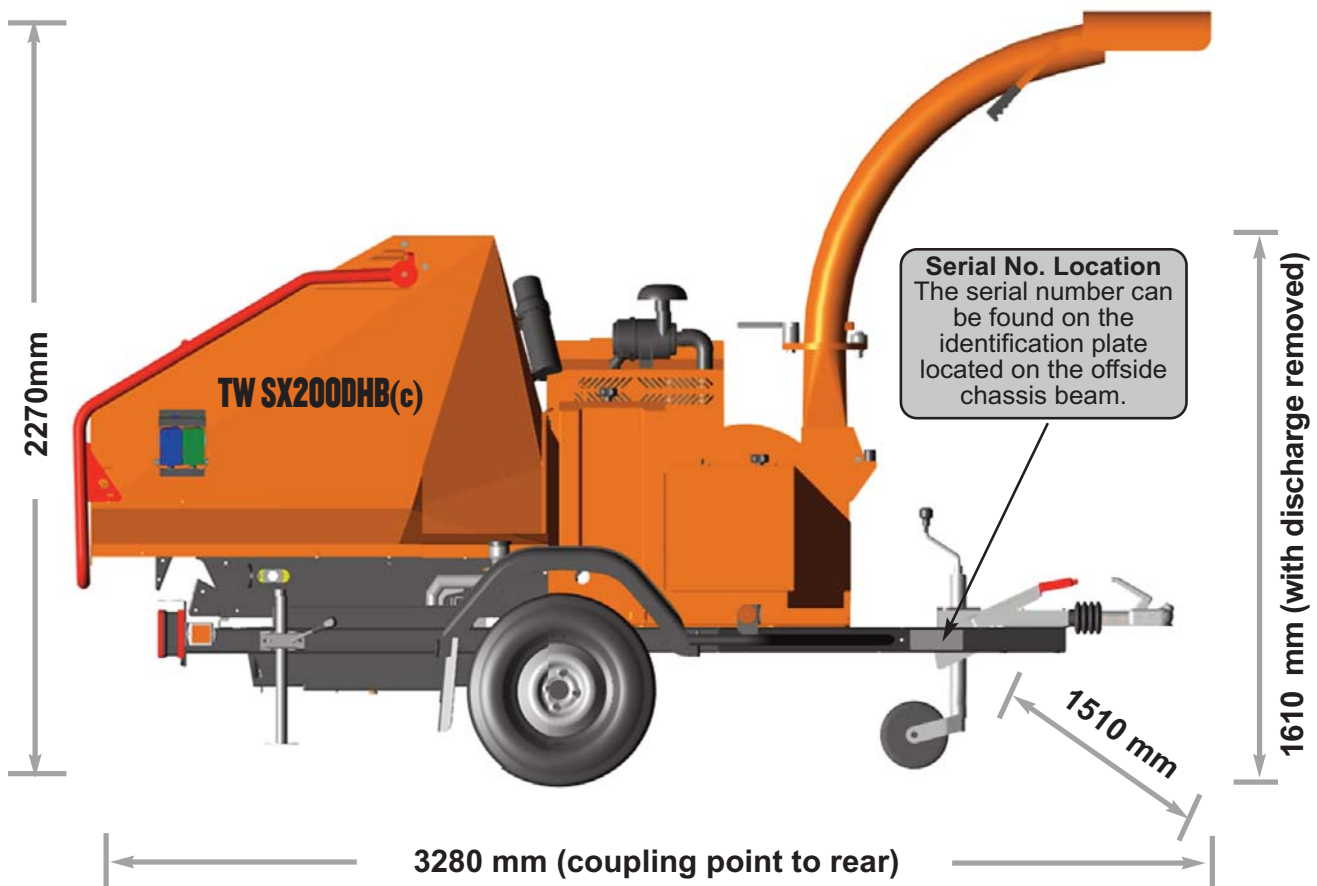

### TIMBERWOLF TW SX200PHB(c) SPECIFICATION

<b>Engine type:</b>	<i>Kubota diesel</i>	<b>Roller feed:</b>	<i>Hydraulic motor</i>
<b>Maximum power:</b>	<i>18.5 kW (25hp)</i>	<b>Maximum diameter material:</b>	<i>100 mm (4")</i>
<b>Cooling method:</b>	<i>Water cooled</i>	<b>Fuel capacity:</b>	<i>16 litres</i>
<b>Overall weight:</b>	<i>748 kg (with conveyor)</i> <i>700 kg (without conveyor)</i>	<b>Hydraulic oil capacity:</b>	<i>15 litres</i>
<b>Starting method:</b>	<i>Electric</i>	<b>Material processing capacity:</b>	<i>up to 2.5 tonnes/hr</i>
		<b>Fuel type:</b>	<i>Diesel</i>



## The Timberwolf TW SX200 - PETROL MODELS

The Timberwolf SX200PHB(c) is a high speed, professional shredder. It is designed to shred general green waste (brush, general prunings, hedge trimmings, leylandii, Christmas trees, root balls, nursery waste (such as packaging, plastic plant pots/seed trays etc), gorse, black-thorn, laurel, privet and cotoneaster etc.

The maximum feed aperture opening is 150mm; the machine will handle solid brushwood up to a maximum diameter of 100mm.

The shredder mechanism is robust enough to tolerate medium levels of contamination such as dirt, small stones, tin cans, nails and other similar small items.

### DIMENSIONS

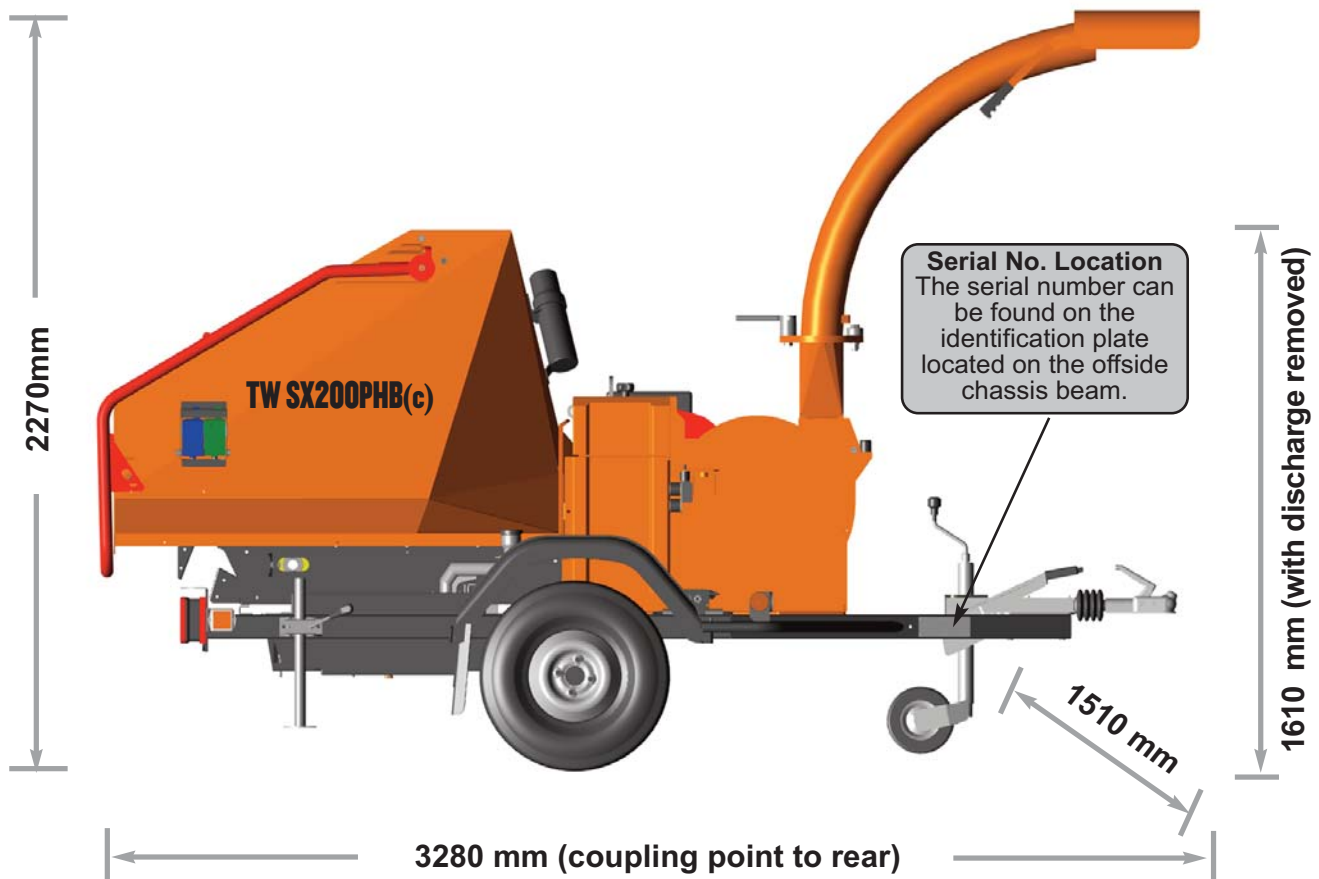

### TIMBERWOLF TW SX200PHB(c) SPECIFICATION

<b>Engine type:</b>	<i>Honda V-twin petrol</i>	<b>Roller feed:</b>	<i>Hydraulic motor</i>
<b>Maximum power:</b>	<i>14.9 kW (20hp)</i>	<b>Maximum diameter material:</b>	<i>100 mm (4")</i>
<b>Cooling method:</b>	<i>Air cooled</i>	<b>Fuel capacity:</b>	<i>16 litres</i>
<b>Overall weight:</b>	<i>745 kg (with conveyor)</i> <i>700 kg (without conveyor)</i>	<b>Hydraulic oil capacity:</b>	<i>15 litres</i>
<b>Starting method:</b>	<i>Electric</i>	<b>Material processing capacity:</b>	<i>up to 2 tonnes/hr</i>
		<b>Fuel type:</b>	<i>Unleaded petrol</i>



## PARTS LOCATOR - DIESEL MODELS

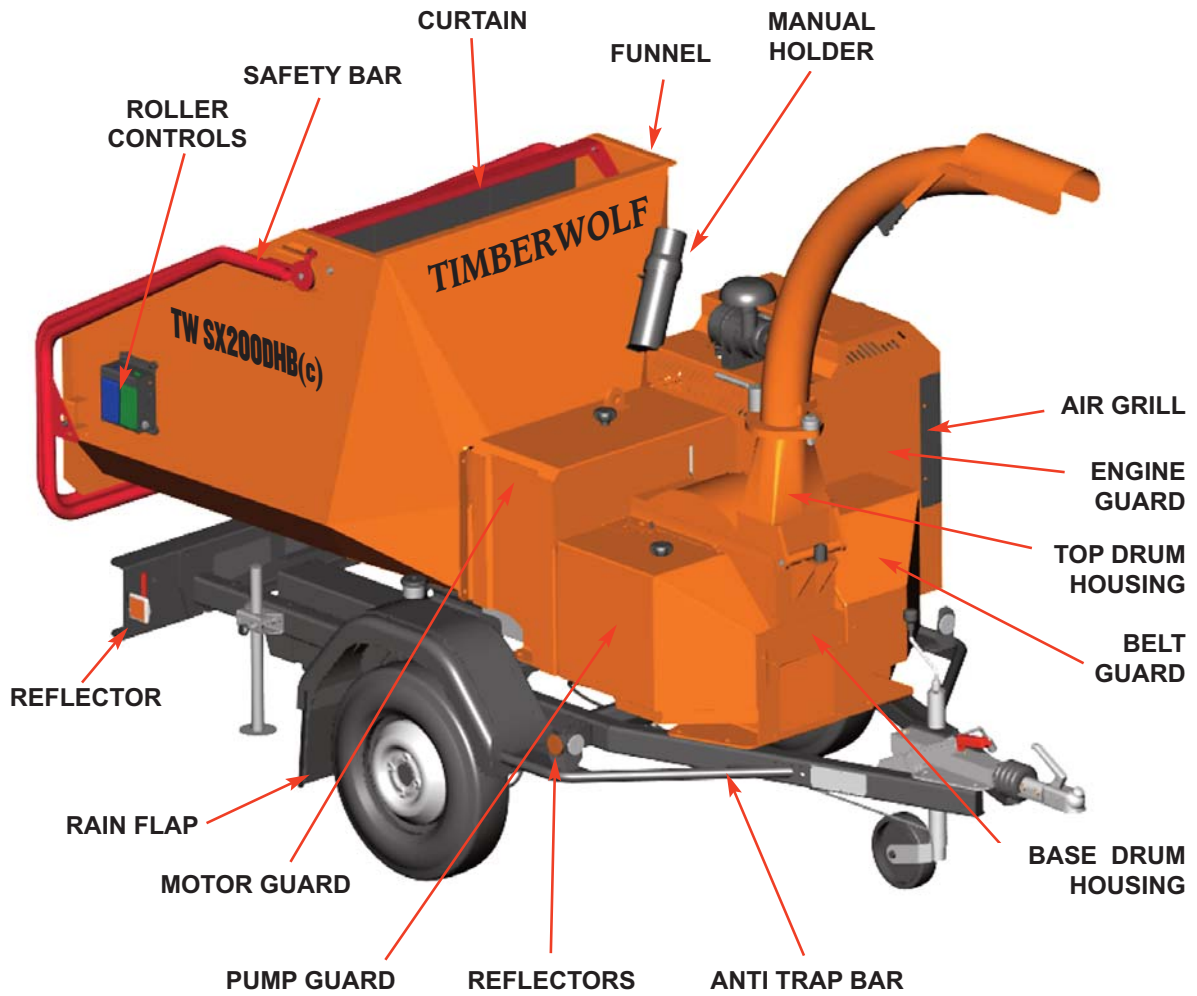

## PARTS LOCATOR - PETROL MODELS







# PARTS LOCATOR - ALL SX200 MODELS

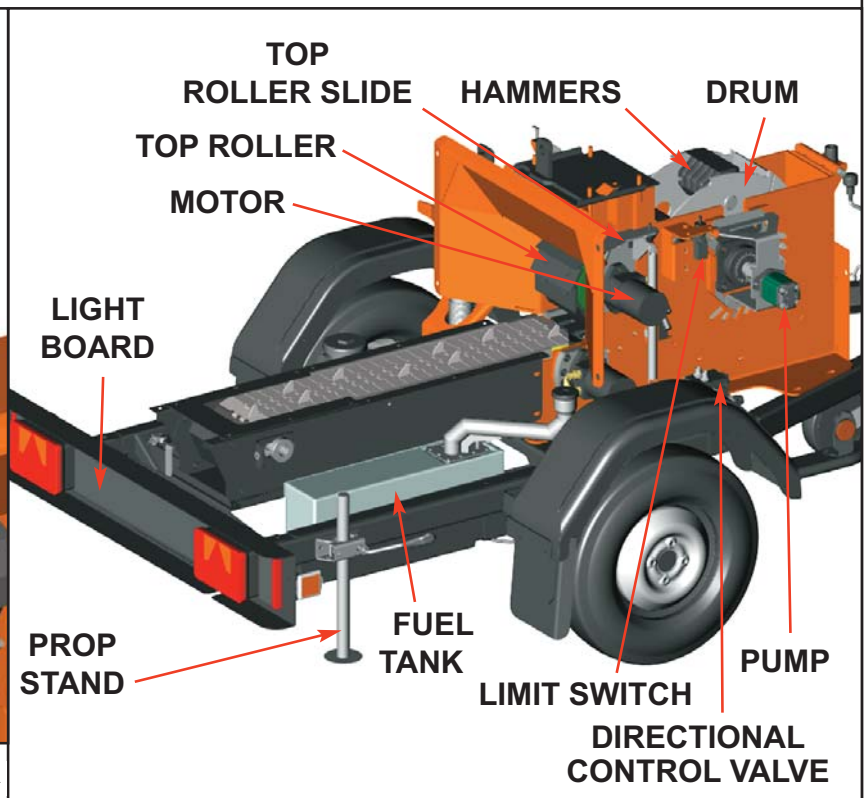
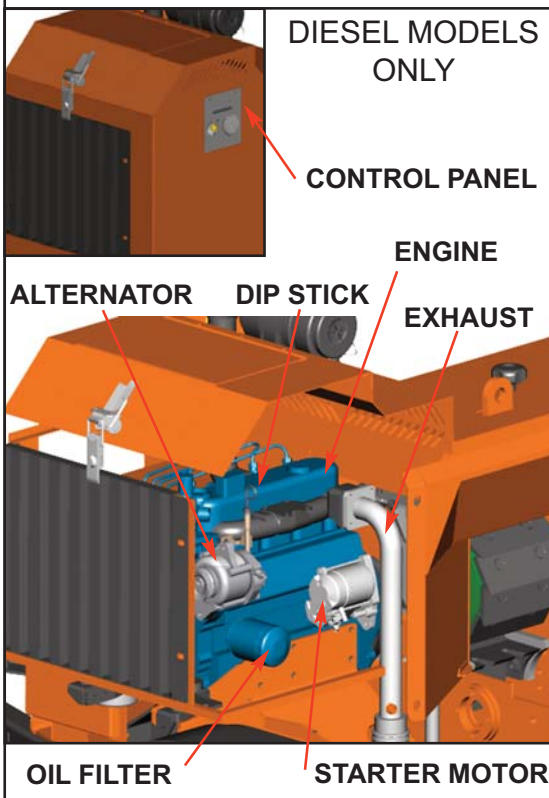
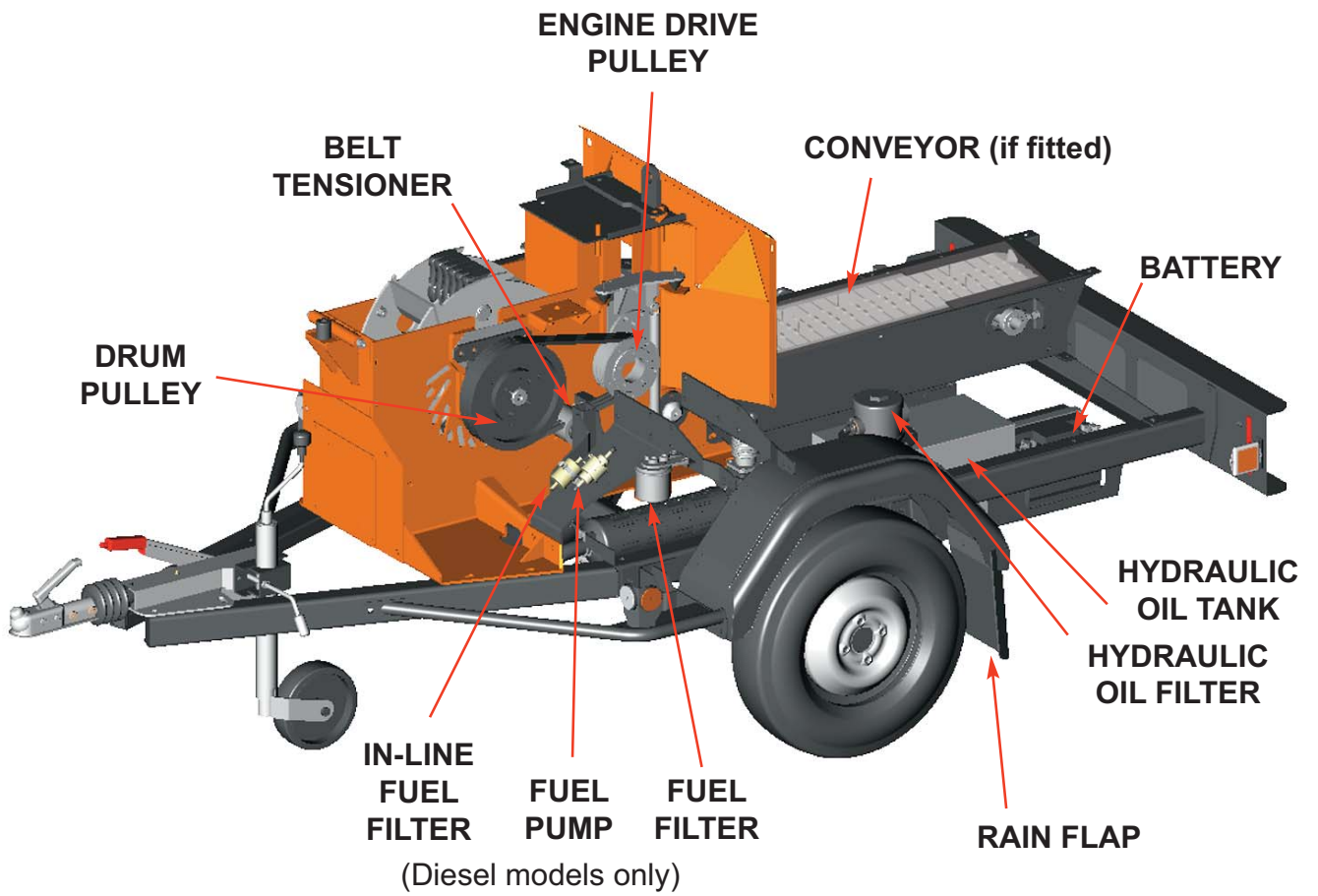



## WARNING

The shredder will feed material through on its own. To do this, it relies on the hammers to be free to swing. **DO NOT** put bricks, large stones, string, carpet, tyres or metal into the shredder.



## OPERATOR'S PERSONAL PROTECTIVE EQUIPMENT REQUIRED



Chainsaw safety helmet fitted with mesh visor and recommended ear defenders to the appropriate specifications.



Close fitting heavy-duty non-snag clothing.



Work gloves with elasticated wrist.



Face mask if appropriate.



Steel toe cap safety boots.



**DO NOT** wear rings, bracelets, watches, jewellery or any other items that could be caught in the material and draw you into the shredder.

## BASIC SHREDDING SAFETY

*The operator should be aware of the following points:*

- **MAINTAIN A SAFETY EXCLUSION ZONE** around the shredder of at least 10 metres for the general public or employees without adequate protection. Due to the nature of material being shredded and the distance/velocity of discharge, the exclusion zone must be extended to 20 metres in front of the discharge tube exit. Use hazard tape to identify this working area and keep it clear from debris build up. Shredded material should be ejected away from any area the general public have access to.
- **HAZARDOUS MATERIAL** - Some species of trees and bushes are poisonous. The shredding action can produce vapour, spray and dust that can irritate the skin. This may lead to respiratory problems or even cause serious poisoning. Check the material to be shredded before you start. Avoid confined spaces and use a facemask if necessary.
- **BE AWARE** when the shredder is processing material that is an awkward shape. The material can move from side to side in the funnel with great force. If the material extends beyond the funnel, the brash may push you to one side causing danger.
- **BE AWARE** that the shredder can eject material out of the feed funnel with considerable force. Always wear full head and face protection.
- **ALWAYS** work on the side of the machine furthest from any local danger, e.g. not road side.



# GENERAL SAFETY MATTERS



## DO'S AND DON'TS



**ALWAYS** stop the shredder engine before making any adjustments, refuelling or cleaning.

**ALWAYS** check machine has stopped rotating and remove shredder ignition key before maintenance of any kind, or whenever the machine is to be left unattended.

**ALWAYS** check machine is well supported and cannot move.

**ALWAYS** run with the engine set to maximum speed.

**ALWAYS** check (visually) for fluid leaks.

**ALWAYS** take regular breaks. Wearing personal protective equipment for long periods can be tiring and hot.

**ALWAYS** keep hands, feet and clothing out of feed opening, discharge and moving parts.

**ALWAYS** use the next piece of material or a push stick to push in short pieces. Under no circumstances should you reach into the funnel.

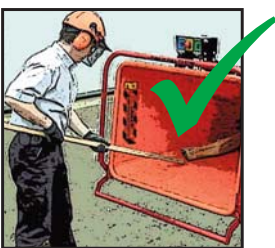

**ALWAYS** keep the operating area clear of people, animals and children.

**ALWAYS** keep the operating area clear from debris build up.

**ALWAYS** keep clear of the discharge tube. Foreign objects may be ejected with great force.

**ALWAYS** ensure protective guarding is in place before commencing work. Failure to do so may result in personal injury or loss of life.

**ALWAYS** use shredder in a well ventilated area - exhaust fumes are dangerous.

**DO NOT** use shredder unless available light is sufficient to see clearly.

**DO NOT** use or attempt to start the shredder without the feed funnel, belt guard, guards and discharge unit securely in place.

**DO NOT** start the shredder running unless properly guarded.

**DO NOT** stand directly in front of the feed funnel when using the shredder. Stand to one side.

**DO NOT** allow -



BRICKS



STRING

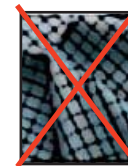

METAL

CLOTH OR  
CARPET

RUBBER

LARGE  
STONES

- to enter the machine, as damage is likely.

**DO NOT** smoke when refuelling. Petrol/diesel fuel is explosive!



**DO NOT** let anyone who has not received instruction operate the machine.

**DO NOT** climb on the machine at any time.

**DO NOT** handle material that is partially engaged in the machine.

**DO NOT** touch any exposed wiring while machine is running.

**DO NOT** use the shredder inside buildings.





# NOISE TEST

**MACHINE: TW SX200 - ALL MODELS**

**NOTES: Tested chipping 120mm x 120mm corsican pine 1.5m in length**

*Noise levels above 80dB (A) will be experienced at the working position. Wear ear protection at all times to prevent possible damage to hearing. All persons within a 4 metre radius must also wear good quality ear protection.*

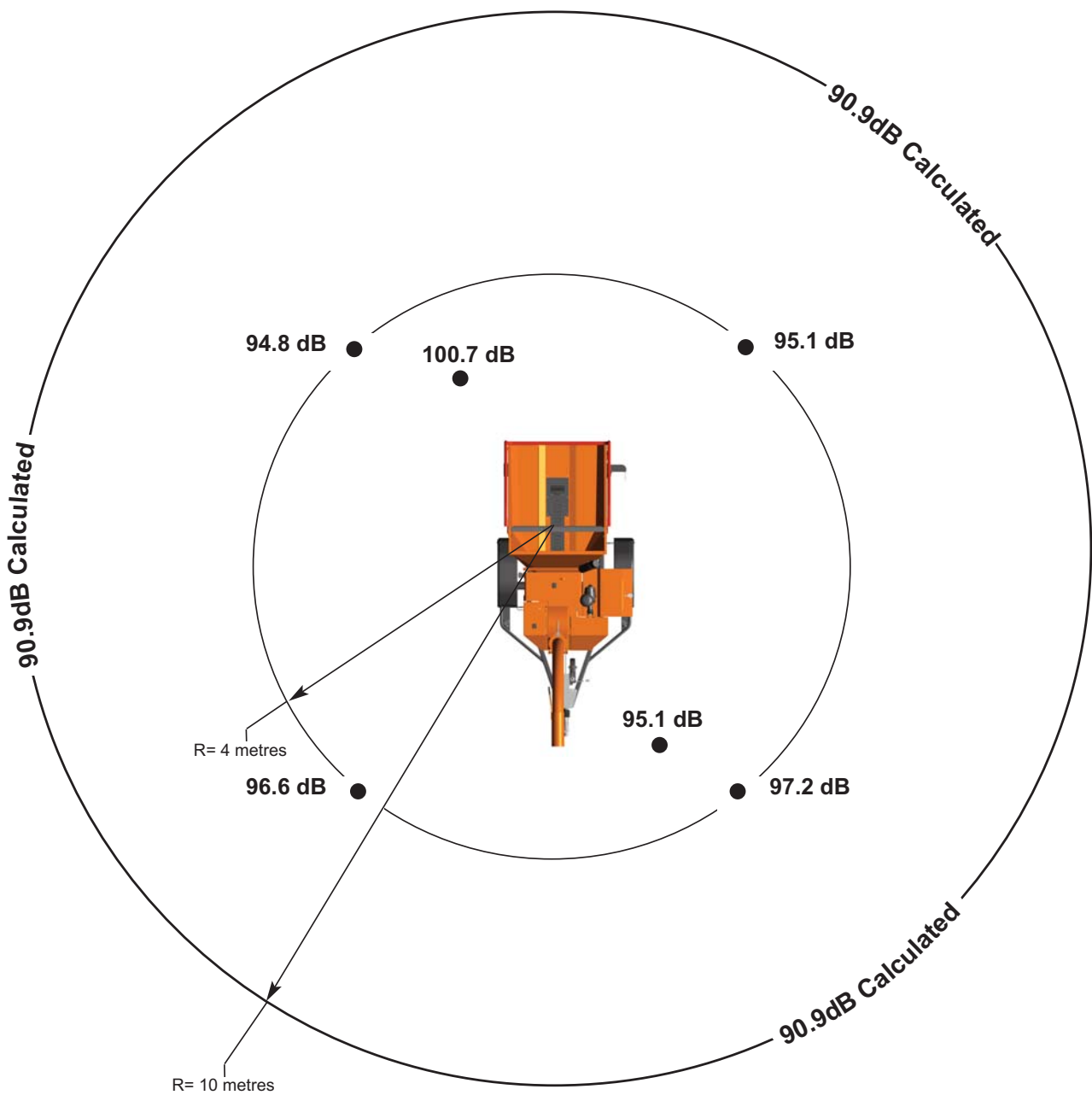

**Guaranteed Sound Power: 120dB (A)**

*As required by Annex III of Directive 2000/14/EC "Noise Emission in the environment by equipment for use outdoors".*



## SAFE TRANSPORTATION

### WARNING

DO NOT RIDE ON THE SHREDDER WHEN IT IS BEING TOWED.



- WHEN towing a shredder the maximum speed limit is 60 mph (100 kph).
- ON rough or bumpy road surfaces reduce speed accordingly to protect your machine from unnecessary vibration.
- WHEN towing off road be aware of objects that may catch the shredder undergear.
- WHEN towing off road ensure inclination is not excessive.
- AVOID excessively pot holed ground.
- WHEN reversing the shredder the short wheel base will react quickly to steering.
- ALWAYS check the discharge is tight before moving.
- KEEP tyre pressures inflated to 2.2 bar (32 psi).
- CHECK wheel nuts are tightened to 90Nm (65 lbs ft).
- CLEAR loose shreddings and debris from the machine before departing.
- ENSURE safety bar catch is properly engaged before departing

## HITCHING ONTO THE TOW BALL

- CHECK ball head is well greased.
- WIND jockey wheel assembly anticlockwise until the tow head is above the height of the ball hitch on the vehicle.
- REVERSE vehicle so the ball hitch is directly below the tow head.
- ATTACH breakaway cable to a strong point on the vehicle, not the ball hitch.
- GRASP handle on tow head and push back catch with thumb.
- WIND jockey wheel assembly clockwise, to lower the tow head onto the ball hitch.
- RELEASE handle and continue to wind jockey wheel clockwise. The tow head should snap into place on the ball hitch. If it doesn't, repeat previous 2 steps.
- WIND jockey wheel up until fully retracted and the jockey wheel frame is seated in its notch on the stem. The chipper weight should be fully on the vehicle.
- RELEASE jockey wheel clamp and slide the jockey wheel assembly fully up.
- TIGHTEN clamp on jockey wheel assembly.
- CONNECT electrical plug to socket on rear of towing vehicle and check operation of all the trailer and vehicle lights.
- THE shredder is now properly attached to the vehicle.

## UNHITCHING THE SHREDDER

- APPLY handbrake.
- DISCONNECT the electrical cable from the vehicle socket.
- RELEASE breakaway cable.
- RELEASE the jockey wheel assembly clamp.
- LOWER the jockey wheel assembly fully.
- RETIGHTEN the jockey wheel assembly clamp.
- WIND the jockey wheel assembly anticlockwise until it starts to take the weight of the shredder.
- GRASP the handle and release the catch with your thumb.
- CONTINUE to wind the jockey wheel anticlockwise. This should lift the tow head clear of the ball hitch.
- DRIVE the vehicle clear of the shredder.
- WIND the jockey wheel assembly to a suitable point where the shredder is level.
- THE shredder is now fully detached from the vehicle.

## STABILISING THE SHREDDER

When hitched to a vehicle the shredder handbrake should be released and the prop stand and jockey wheel stored in the towing position (a).

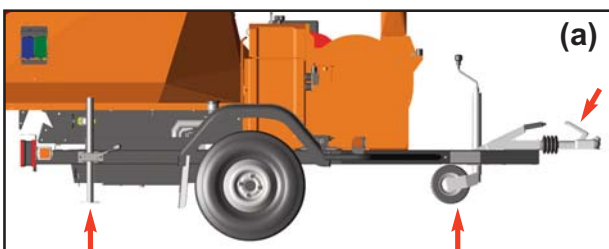

When the shredder is unhitched it should be made secure before starting work by applying the handbrake and lowering the prop stand and jockey wheel (b).

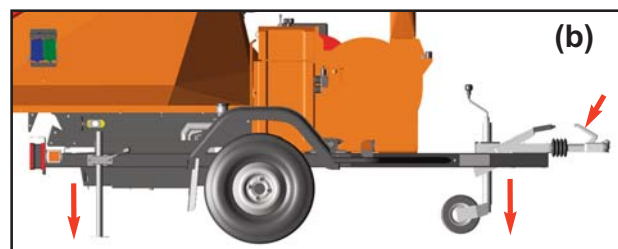



## DELIVERY

All Timberwolf TW SX200 machines have a full pre - delivery inspection before leaving the factory and are ready to use. Read and understand this instruction manual before attempting to operate the shredder. In particular, read pages 6 -8 which contain important health and safety information and advice.

## OPERATOR'S PERSONAL PROTECTIVE EQUIPMENT REQUIRED

- CHAINSAW safety helmet fitted with visor and recommended ear defenders to an appropriate specification.
- HEAVY-DUTY gloves with elasticated wrist area.
- CLOSE - FITTING heavy-duty non-sag clothing.
- SAFETY footwear.
- FACE MASK (if appropriate).

See page 6 for more detailed information.

## MANUAL CONTROLS

Roller control boxes- two control boxes are located on either side of the feed funnel. Their function is to control the feed roller\* whilst processing material. **They do not control the main drum.**

**RED SAFETY BAR** = This is the large red bar that surrounds the feed funnel. The bar is spring loaded and connected to a switch that will interrupt the power to the roller. The switch is designed so that it only activates if the bar is pushed to the limit of its travel. The roller will stop instantly, but can be made to turn again by pressing either the **GREEN FEED** or **BLUE REVERSE** control buttons.

### RED SAFETY BAR TEST

To ensure the safety bar is always operational it must be activated once before each work session.

## WARNING

**DO NOT** remove, jam, disable, bypass, override or otherwise impede the effectiveness of the red safety bar.



**GREEN BUTTON** = Forward feed - push the button once - this activates the in-feed roller\* and will allow you to start shredding (if the drum speed is high enough).

**BLUE BUTTON** = Reverse feed - push the button continuously to back material out of the shredder. The in-feed roller\* will only turn in reverse as long as you keep pressing the button.

### Control Box Diagram

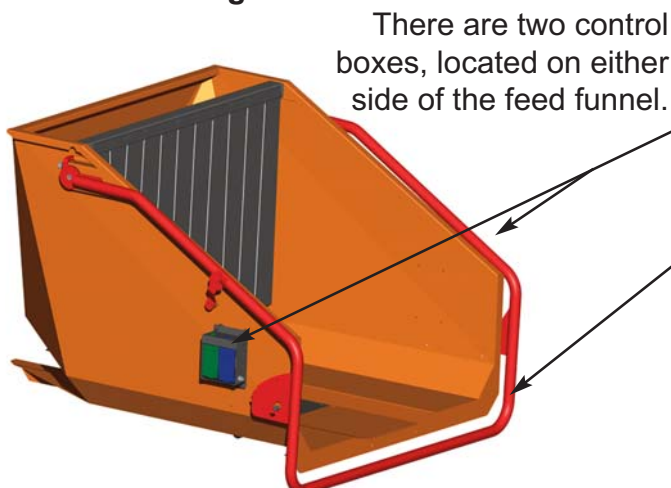

There are two control boxes, located on either side of the feed funnel.

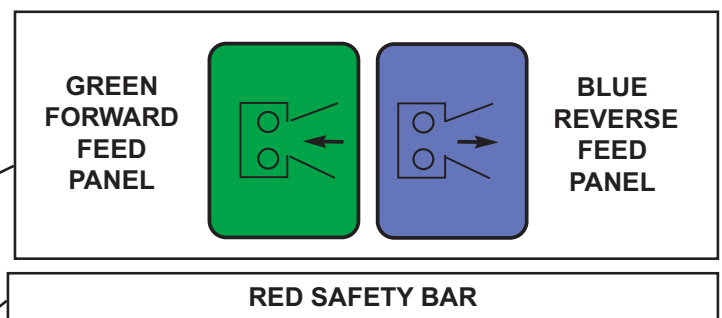

Do not rely on the red bar to keep the in-feed roller\* stationary if it is necessary to clear or touch either. Always switch off the machine and remove ignition key before approaching the in-feed roller.\*

\*in-feed roller and conveyor if conveyor option fitted

## AUTO CONTROLS

The no stress unit controls the feed rate of the material going into the shredding chamber. If the drum speed is below the predetermined level, the no stress unit will not allow the in-feed roller or conveyor to work in the forward direction, until the drum speed rises above the predetermined level. At this point, the in-feed roller will start turning without warning.

## EMERGENCY STOPPING

**Push the red safety bar. Turn off the engine ignition key.** The drum will still be turning. The engine must be powered down to stop the drum.

## HYDRAULIC OIL LEVEL INDICATOR

The oil level will be visible through the tank wall. It should be within the upper and lower level marks.

## FUEL LEVEL INDICATOR

The fuel level can be seen through the wall of the plastic tank.

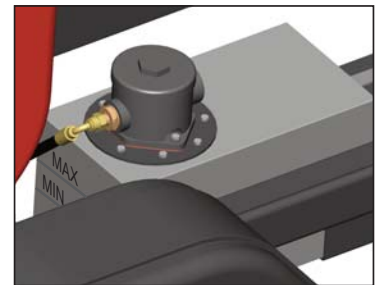

## DAILY CHECKS BEFORE STARTING

- LOCATE the machine on firm level ground.
- CHECK machine is well supported and cannot move.
- CHECK prop stand is lowered and secure.
- CHECK all guards are fitted and secure.
- CHECK the discharge unit is in place and fastened securely.
- CHECK discharge tube is pointing in a safe direction.
- CHECK the feed funnel to ensure no objects are inside.
- CHECK for free rotation of drum and hammers (see instructions on page 20).
- CHECK controls as described on page 12.
- CHECK (visually) for fluid leaks.
- CHECK fuel and hydraulic oil levels.

*For parts location see diagrams on pages 4 & 5.*

## DISCHARGE CONTROLS

Controlling the discharge is an essential part of safe working.

### ROTATION

1. Slacken nut using integral handle.
2. Rotate tube.
3. Retighten nut.

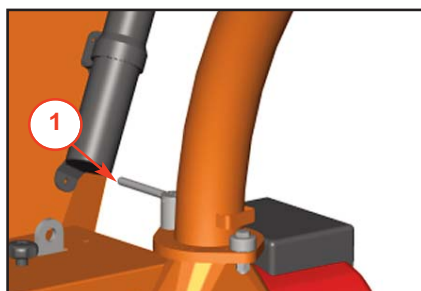

### BUCKET ANGLE

4. Adjust the bucket to the desired angle using the handle provided.

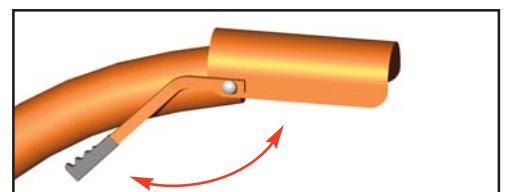





### ENGINE CONTROLS - DIESEL MODELS

The engine speed is controlled by the horizontally adjustable lever shown in the drawing. With the throttle lever in the FAST position the machine is ready to chip. It MUST be fully pushed to the left to achieve a suitable working speed. If no wood is to be chipped for a few minutes the throttle should be returned to the idle position.



### BEFORE USING THE SHREDDER- DIESEL MODELS

IT IS ESSENTIAL TO CARRY OUT THE FOLLOWING TESTS to check safety equipment - this sequence of tests will only take a few seconds to carry out. We recommend that these tests are carried out daily. Observing the function as described will confirm that the safety circuits are working correctly. This is also a good opportunity to remind all operators of the control and emergency stop systems.

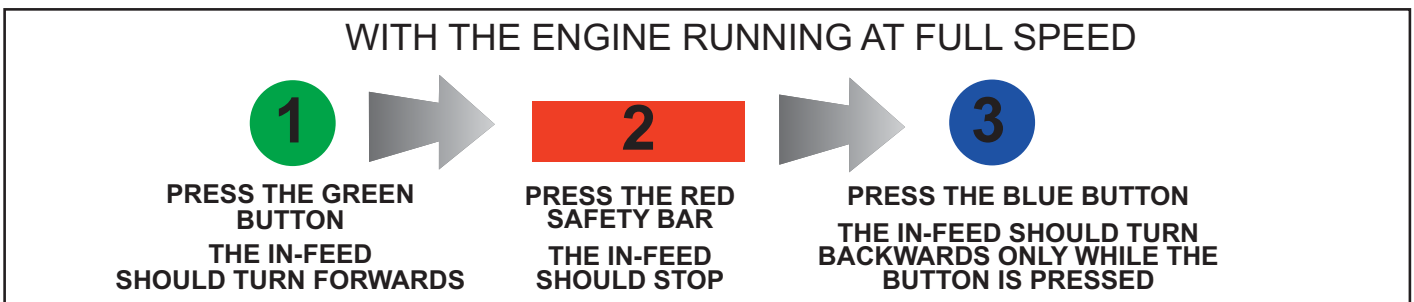

### STARTING THE ENGINE- DIESEL MODELS

- ENSURE throttle lever is in the slow (tortoise) position.
- INSERT key. Turn to heat.
- HEATER LED comes on.
- WAIT FOR HEATER LED TO GO OUT.
- TURN key to engage starter motor.
- RELEASE key once engine starts.

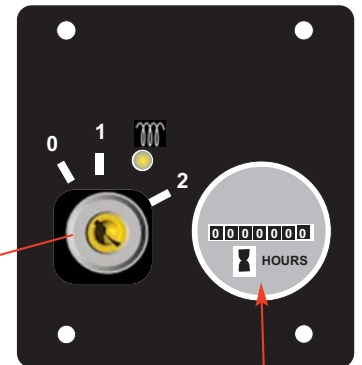

HOURS COUNTER

*Do not engage starter motor for more than 20 seconds - allow one minute before attempting to start. Investigate reasons for failure to start. Do not continuously crank engine.*

### STOPPING THE ENGINE- DIESEL MODELS

- MOVE the throttle lever to the 'Tortoise' to reduce the engine speed to idle.
- LEAVE the engine running for 1 minute.
- TURN the power switch to position 0. The engine should stop after a few seconds.
- REMOVE the ignition key.

*For more detailed information refer to the Engine Owner's Manual*



### ENGINE CONTROLS - PETROL MODELS

This label indicates the speed setting of the shredder. With the throttle lever in the fast position (hare) the machine is ready to shred.

When the machine is not in use for short periods of time move the lever to the idle position (tortoise) or turn off completely.



### BEFORE USING THE SHREDDER - PETROL MODELS

IT IS ESSENTIAL TO CARRY OUT THE FOLLOWING TESTS to check safety equipment - this sequence of tests will only take a few seconds to carry out. We recommend that these tests are carried out daily - **checking the control boxes on both sides of the funnel**. Observing the function as described will confirm that the safety circuits are working correctly. This is also a good opportunity to remind all operators of the control and emergency stop systems.

WITH THE ENGINE RUNNING AT FULL SPEED

1

PRESS THE GREEN BUTTON  
THE IN-FEED SHOULD TURN FORWARDS



2

PRESS THE RED SAFETY BAR  
THE IN-FEED SHOULD STOP



3

PRESS THE BLUE BUTTON  
THE IN-FEED SHOULD TURN BACKWARDS ONLY WHILE THE BUTTON IS PRESSED

### STARTING THE ENGINE - PETROL MODELS



- FOR A COLD ENGINE:**  
Place the throttle control at 1/3 throttle and pull the choke out. Insert ignition key into starter switch. Turn the key to start the engine. Release the key as soon as the engine starts. Gradually return the choke to the off position as the engine starts and warms up. Allow the engine to warm up for at least one minute before shredding.
- FOR A WARM ENGINE:**  
Follow the instructions for a 'cold engine' but return the choke to the off position as soon as the engine starts.

*If engine fails to start after 10 seconds leave for 1 minute and try again. Do not continuously crank engine.*

### STOPPING THE ENGINE - PETROL MODELS

- MOVE the throttle lever to the 'Tortoise' to reduce the engine speed to idle.
- LEAVE the engine running for 1 minute.
- TURN the power switch to position 0. The engine should stop after a few seconds.
- REMOVE the ignition key.

*For more detailed information refer to the Engine Owner's Manual*



## STARTING TO SHRED

### WARNING

Do not use or attempt to start the shredder without the protective guarding and discharge unit securely in place. Failure to do so may result in personal injury or loss of life.



- CHECK that the shredder is running smoothly.
- PERFORM the “before using the shredder” tests (see page 13).
- PRESS the green control button. The in-feed will commence turning.
- STAND to one side of the feed funnel.
- PROCEED to feed material into the feed funnel.

## SHREDDING

Wood up to the recommended diameter can be fed into the feed funnel. Put the butt end in first and engage it with the feed roller. The hydraulic feed roller will pull the branch into the machine quite quickly. Large diameter material will have its feed rate automatically controlled by the no stress unit.

Sometimes a piece of wood that is a particularly awkward shape is too strong for the feed rollers to break. This will cause the in-feed roller to either bounce up and down on the wood, or stall. If this occurs, press the **BLUE REVERSE** button until the material has been released. Pull the material out of the feed funnel and trim it so the shredder can handle it.

If the roller stops or suddenly slows down it may be that a piece of wood has become stuck behind the roller. If this occurs, press the **BLUE REVERSE** button and hold for 2 seconds - then repress **GREEN FEED** button. This should enable the roller to free the offending piece of material and continue rotating at the correct speed. If the roller continues to stall in the 'forward feed' or 'reverse feed' position push the **RED STOP BAR**, turn the engine off, remove the ignition key and investigate.

## BLOCKAGES

Always be aware that what you are putting into the shredder must come out. If the shreds stop coming out of the discharge tube but the shredder is taking material in - STOP IMMEDIATELY. Continuing to feed material into a blocked machine may cause damage and will make it difficult to clear.

***If the shredder becomes blocked, proceed as follows:***

- STOP the engine and remove the ignition keys.
- REMOVE the discharge tube. Check that it is clear.
- WEARING gloves, reach into the drum housing and scoop out the majority of the debris causing the blockage.

### WARNING

Do not reach into the drum housing with unprotected hands. There are sharp edges and any small movement of the drum may cause serious injury.



- REPLACE the discharge tube.
- RESTART the engine and increase to full speed.
- ALLOW machine time to clear excess shreds still remaining in drum housing before you continue feeding brushwood. Feed in a small piece of wood while watching to make sure that it comes out of the discharge. If this does not clear it, repeat the process and carefully inspect the discharge tube to find any obstruction.

### NOTE

Continuing to feed the shredder with brushwood once it has become blocked will cause the shredder to compact the shreds in the drum housing and it will be difficult and time consuming to clear.

**AVOID THIS SITUATION - WATCH THE DISCHARGE TUBE AT ALL TIMES.**



**THE FOLLOWING PAGES DETAIL ONLY  
BASIC MAINTENANCE GUIDELINES SPECIFIC  
TO YOUR SHREDDER.**



## **THIS IS NOT A WORKSHOP MANUAL.**

THE FOLLOWING GUIDELINES ARE NOT EXHAUSTIVE AND DO NOT EXTEND TO GENERALLY ACCEPTED STANDARDS OF ENGINEERING/MECHANICAL MAINTENANCE THAT SHOULD BE APPLIED TO ANY PIECE OF MECHANICAL EQUIPMENT AND THE CHASSIS TO WHICH IT IS MOUNTED.

AUTHORISED TIMBERWOLF SERVICE AGENTS ARE FULLY TRAINED IN ALL ASPECTS OF TOTAL SERVICE AND MAINTENANCE OF TIMBERWOLF WOOD SHREDDERS. YOU ARE STRONGLY ADVISED TO TAKE YOUR SHREDDER TO AN AUTHORISED AGENT FOR ALL BUT THE MOST ROUTINE MAINTENANCE AND CHECKS.

TIMBERWOLF ACCEPTS NO RESPONSIBILITY FOR THE FAILURE OF THE OWNER/USER OF TIMBERWOLF SHREDDERS TO RECOGNISE GENERALLY ACCEPTED STANDARDS OF ENGINEERING/MECHANICAL MAINTENANCE AND APPLY THEM THROUGHOUT THE MACHINE.

**THE FAILURE TO APPLY GENERALLY ACCEPTED  
STANDARDS OF MAINTENANCE, OR THE PERFORMANCE  
OF INAPPROPRIATE MAINTENANCE, MAY INVALIDATE  
WARRANTY IN WHOLE OR IN PART.**

**PLEASE REFER TO YOUR AUTHORISED  
TIMBERWOLF SERVICE AGENT FOR  
SERVICE AND MAINTENANCE.**







## SERVICE SCHEDULE

### WARNING

Always immobilise the machine by stopping the engine, removing the ignition key and disconnecting the battery before undertaking any maintenance work.



SERVICE SCHEDULE	Daily Check	50 Hours	100 Hours	500 Hours	1 Year
Check coolant level (diesel models only).	✓				
Check radiator is clear(diesel models only).	✓				
Check engine oil - top up if necessary (10W-30).	✓				
Check for engine oil / hydraulic oil leaks.	✓				
Check tyre pressure is 2.2 bar (32 psi).	✓				
Check feed funnel, feed roller cover, access covers, engine covers and discharge unit are securely fitted.	✓				
Check for free rotation of drum and hammers.	✓				
Check air intake is clear.	✓				
Clean air filter element.	<b>DEPENDING ON WORKING ENVIRONMENT</b>				
Grease the drum bearings.	<b>GREASE DAILY OR AS REQUIRED WITH INFREQUENT USE - SEE PAGE 21</b>				
Grease the roller box slides.		✓	OR AS REQUIRED - SEE PAGE 21		
Grease the roller spline and bearing.		✓	OR AS REQUIRED - SEE PAGE 21		
Check for tightness all nuts, bolts and fastenings making sure nothing has worked loose.		✓			
Check tension of main drive belts (and tension if necessary).		✓			
Grease discharge flange.		✓			
Check condition of anvil and retaining bolts are tight.		✓			
Check fuel pipes and clamp bands (petrol models only)		✓			
Grease jack stand.			✓		
Check battery electrolyte level.			✓		
Check for loose electrical wiring.			✓		
Replace hydraulic oil filter - every year or 100 hours after service or repair work to the hydraulic system.			✓	OR	✓
Replace hydraulic oil.			✓	OR	✓
Service tow head/adjustable tow head.	<b>SEE</b>				
Axle maintenance.	<b>MANUFACTURERS</b>				
Road brake maintenance.	<b>SHEET FOR DETAILS</b>				
Replace anvil when worn.	<b>RETURN TO DEALER FOR ANVIL CHANGE</b>				
Change engine oil .	<b>REFER TO YOUR</b>				
Replace engine oil filter cartridge.	<b>ENGINE SUPPLIERS MANUAL</b>				
Check valve clearance.	<b>REFER TO YOUR</b>				
Replace spark plugs (petrol models only).	<b>ENGINE SUPPLIERS MANUAL</b>				

**NOTE:** Your Timberwolf shredder is covered by a full 12 months parts and labour warranty. Subject to correct maintenance and proper machine usage, the bearings are guaranteed for 12 months regardless of hours worked by the machine. In conditions of 'heavy usage' - i.e. in excess of 500 hours per year - it is recommended that the bearings are changed annually to ensure that the machine retains optimum working performance.

## SAFE MAINTENANCE

**ALWAYS IMMOBILISE THE ENGINE BEFORE UNDERTAKING ANY MAINTENANCE WORK ON THE SHREDDER BY REMOVING THE KEY AND DISCONNECTING THE BATTERY.**

- HANDLE hammers with extreme caution to avoid injury. Gloves should always be worn when handling the hammers.
- THE drive belts should be connected while changing hammers, as this will restrict sudden movement of the drum.
- THE major components of this machine are heavy. Lifting equipment must be used for disassembly.
- CLEAN machines are safer and easier to service.
- AVOID contact with hydraulic oil and fuel.

## SAFE LIFTING OF THE SHREDDER

The lifting eye is designed to lift the machine's weight only. Do not use hoist hook directly on the lifting eye, use a correctly rated safety shackle. Inspect the lifting eye prior to each use - DO NOT USE LIFTING EYE IF DAMAGED.

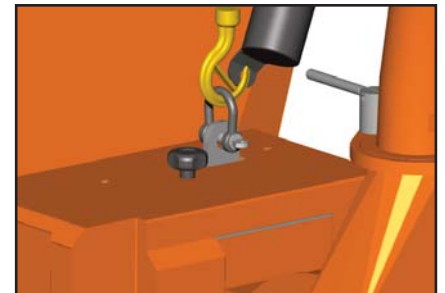

## SPARES

Only fit genuine Timberwolf replacement screws and shredder spares. Failure to do so will result in the invalidation of the warranty and may result in damage to the shredder, personal injury or even loss of life.

## BATTERY REMOVAL AND MAINTENANCE

### WARNING

Refer to the battery safety section on pages 18-19.



1. Remove the negative lead first and then the positive lead.
2. Clean, charge and/or top up the battery as required.
3. Refitting is the reverse of removal. Apply a smear of vaseline to the terminals to prevent corrosion.

## CHECK FITTINGS

Timberwolf TW SX200 models are subject to large vibrations during the normal course of operation. Consequently there is always a possibility that nuts and bolts will work themselves loose. It is important that periodic checks are made to ensure the security of all fasteners. Fasteners should be tightened using a torque wrench to the required torque (see below). **Uncalibrated torque wrenches can be inaccurate by as much as 25%. It is therefore essential that a calibrated torque wrench is used to achieve the tightening torques listed below.**

	Size	Pitch	Head	Torque lbft	Torque Nm
Roller Support Bearing	M10	Standard	8mm Allen Key	20	27
Drum Housing Clamp Nuts	M16	Standard	24 mm Hex	40	54
Hyd Motor Retaining Cap Screws	M12	Standard	10 mm Allen Key	60	81
Roller Box Retaining Bolts	M16	Standard	24 mm Hex	105	140
Rotor Shaft Retaining Screws	M12	Standard	10 mm Allen Key	105	140
Funnel Retaining Nuts	M12	Standard	19 mm Hex	60	80
General	M8	Standard	13 mm Hex	17	23
General	M10	Standard	17 mm Hex	34	46
General	M12	Standard	19 mm Hex	60	80



## COPPER EASE SAFETY INFORMATION

**Product name: Copper Ease.**

Copper Ease contains no hazardous ingredients at or above regulatory disclosure limits, however, safety precautions should be taken when handling (use of oil-resistant gloves and safety glasses are recommended - respiratory protection is not required). Avoid direct contact with the substance and store in a cool, well ventilated area avoiding sources of ignition, strong oxidising agents and strong acids. Dispose of as normal industrial waste (be aware of the possible existence of regional or national regulations regarding disposal), do not discharge into drains or rivers.

**In case of fire:** in combustion the product emits toxic fumes, extinguish with alcohol or polymer foam, carbon dioxide or dry chemical powder. Wear self-contained breathing apparatus and protective clothing to prevent contact with skin and eyes.

### FIRST AID

**Skin contact:** there may be mild irritation at the site of contact, wash immediately with plenty of soap and water.

**Eye contact:** there may be irritation and redness, bathe the eye with running water for 15 minutes.

**Ingestion:** there may be irritation of the throat, do not induce vomiting, wash out mouth with water.

**A safety data sheet for this product can be obtained by writing to the manufacturer at the following address: Comma Oil and Chemicals Ltd., Deering Way, Gravesend, Kent DA12 2QX. Tel: 01474 564311, Fax: 01474 333000.**

## BATTERY SAFETY INFORMATION

### WARNING NOTES AND SAFETY REGULATIONS FOR FILLED LEAD-ACID BATTERIES



For safety reasons, wear eye protection when handling a battery.



Keep children away from acid and batteries.



Fires, sparks, naked flames and smoking are prohibited.  
-Avoid causing sparks when dealing with cables and electrical equipment, and beware of electrostatic discharges.  
-Avoid short circuits, otherwise:



Explosion hazard:  
-A highly explosive oxyhydrogen gas mixture is produced when batteries are charged.



Corrosive hazard:  
-Battery acid is highly corrosive, therefore:  
-Wear protective gloves and eye protection.  
-Do not tilt the battery, acid may escape from the vent openings.



First aid:  
-Rinse off acid splashed in the eyes immediately for several minutes with clear water! Then consult a doctor immediately.  
-Neutralise acid splashes on the skin or clothes immediately with acid neutraliser (soda) or soap suds, and rinse with plenty of water.  
-If acid is swallowed, consult a doctor immediately.

*Warning notes: The battery case can become brittle, to avoid this:*



-Do not store batteries in direct sunlight.  
-Discharged batteries may freeze up, therefore store in an area free from frost.



Disposal:  
-Dispose of old batteries at an authorised collection point.  
-The notes listed under item 1 are to be followed for transport.

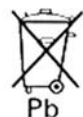

-Never dispose of old batteries in household waste.



## BATTERY SAFETY INFORMATION...cont.

### 1. Storage and transport

- Batteries are filled with acid.
- Always store and transport batteries upright and prevent from tilting so that no acid can escape.
- Store in a cool and dry place.
- Do not remove the protective cap from the positive terminal.
- Run a FIFO (first in-first out) warehouse management system.

### 2. Initial operation

- The batteries are filled with acid at a density of 1.28g/ml during the manufacturing process and are ready for use.
- Recharge in case of insufficient starting power (cf. section 4).

### 3. Installation in the vehicle and removal from the vehicle

- Switch off the engine and all electrical equipment.
- When removing, disconnect the negative terminal first.
- Avoid short circuits caused by tools, for example.
- Remove any foreign body from the battery tray, and clamp battery tightly after installation.
- Clean the terminals and clamps, and lubricate slightly with battery grease.
- When installing, first connect the positive terminal, and check the terminal clamps for tight fit.
- After having fitted the battery in the vehicle, remove the protective cap from the positive terminal, and place it on the terminal of the replaced battery in order to prevent short circuits and possible sparks.
- Use parts from the replaced battery, such as the terminal covers, elbows, vent pipe connection and terminal holders (where applicable); use available or supplied filler caps.
- Leave at least one vent open, otherwise there is a danger of explosion. This also applies when old batteries are returned.

### 4. Charging

- Remove the battery from the vehicle; disconnect the lead of the negative terminal first.
- Ensure good ventilation.
- Use suitable direct current chargers only.
- Connect the positive terminal of the battery to

- the positive output of the charger. Connect the negative terminal accordingly.
- Switch on the charger only after the battery has been connected, and switch off the charger first after charging has been completed.
- Charging current-recommendation: 1/10 ampere of the battery capacity Ah.
- Use a charger with a constant charging voltage of 14.4V for re-charging.
- If the acid temperature rises above 55° Celsius, stop charging.
- The battery is fully charged when the charging voltage has stopped rising for two hours.

### 5. Maintenance

- Keep the battery clean and dry.
- Use a moist anti-static cloth only to wipe the battery, otherwise there is a danger of explosion.
- Do not open the battery.
- Recharge in case of insufficient starting power (cf. section 4).

### 6. Jump Starting

- Use the standardised jumper cable in compliance with DIN 72553 only, and follow the operating instructions.
- Use batteries of the same nominal voltage only.
- Switch off the engines of both vehicles.
- First connect the two positive terminals (1) and (2), then connect the negative terminal of the charged battery (3) to a metal part (4) of the vehicle requiring assistance away from the battery.
- Start the engine of the vehicle providing assistance, then start the engine of the vehicle requiring assistance for a maximum of 15 seconds.
- Disconnect the cables in reverse sequence (4-3-2-1).

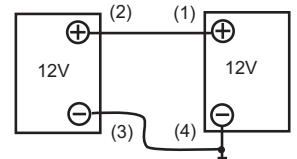

### 7. Taking the battery out of service

- Charge the battery; store in a cool place or in the vehicle with the negative terminal disconnected.
- Check the battery state of charge at regular intervals, and correct by recharging when necessary (cf. section 4).





## CHANGE HAMMERS

### WARNING

Wear heavy gloves for the hammer changing operation

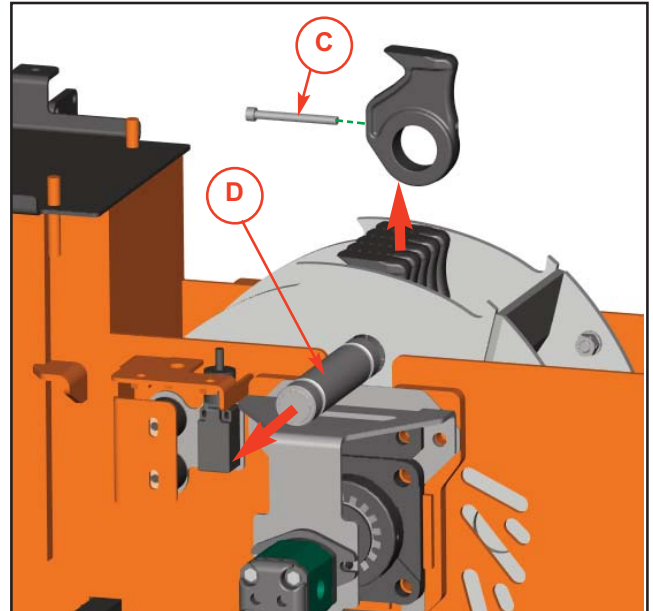
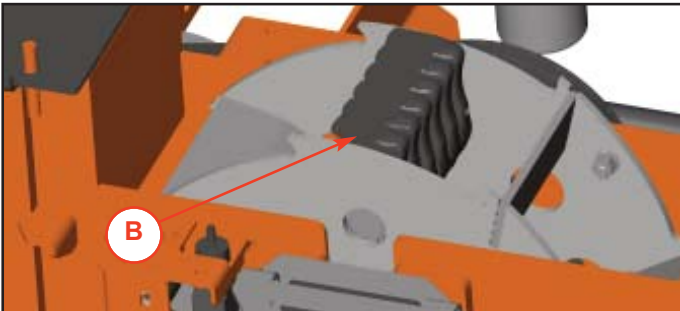
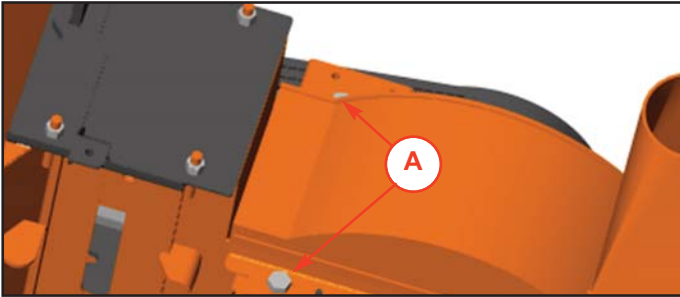

1. Turn off shredder and remove key.
2. Remove the negative battery lead.
3. Turn the discharge tube to point forward of the machine.
4. Using a 24 mm spanner remove the two M16 bolts clamping the drum housing shut (A).
5. Carefully rotate the drum housing until it rests on its stop.
6. Using the paddles to turn the drum, set a bank of hammers at 12 o'clock (B).
7. With a 6mm hex key undo and remove the bolt in the hammer at each end of the bank of hammers (C).
8. The shaft can now be withdrawn. The shaft will need to be tapped away from the main drive pulley side (D).
9. As the shaft is removed the hammers will be released off the shaft. These need to be held and removed as the shaft is withdrawn (D).
10. The hammer replacement is the reverse of the above with the addition of some copper slip on the hammer retainer bolts. Note the hammer bushes should not be greased or lubricated in any way. Any build up of debris should be removed from both the shaft and the hammer bushes so the hammer can swing freely.
11. Turn the drum to change the second bank of hammers.
12. Lower the top of the drum housing and reinstall the two M16 bolts.
13. Torque these to 65lbft.
14. Re-attach the battery lead.

## CHECK FOR FREE ROTATION OF DRUM AND HAMMERS

### WARNING

Wear heavy gloves for the drum/hammer checking operation.



Follow steps 1 - 6 as above then:

1. Check that each of the 6 hammers in this bank all rotate freely through 360°.
2. Turn the drum to check the second bank of hammers.
3. Check all 6 hammers in second bank also rotate freely through 360°.

Follow steps 12 - 14 as above.



## SERVICING THE CONVEYOR

### WARNING

Ensure the engine is switched off before working on the conveyor.



1. To tension the conveyor belt slackon nut (A) approx. 3mm on both sides.
2. Tighten nut (B) up to the bracket on both sides keeping rear roller aligned correctly across base tray.
3. Take care not to over-tension conveyor, tension should be set to remove most of the slack and allow the slats to run smoothly in guides.

Remove panel (C) when needing access to the end of the conveyor, i.e. for removing any jammed items or accumulation of debris.

**NOTE: NEVER RUN THE MACHINE WITH PANEL (C) REMOVED.**

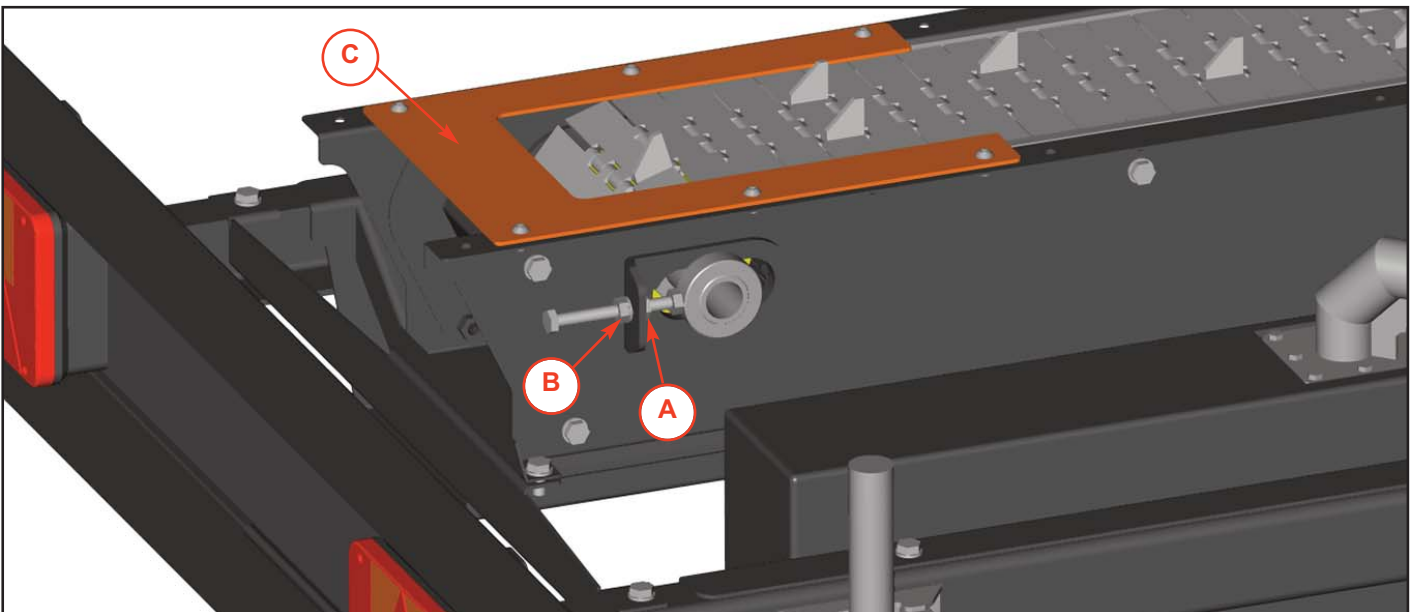

## ENGINE SERVICING

All engine servicing must be performed in accordance with the Engine Manufacturer's Handbook provided with the machine. **FAILURE TO ADHERE TO THIS MAY INVALIDATE WARRANTY AND/OR SHORTEN ENGINE LIFE.**

## CHECK HOSES

All the hydraulic hoses should be regularly inspected for chafing and leaks. The hydraulic system is pressurized to 110 Bar, the equipment containing it must be kept in good condition.

Identify the hoses that run to the top motor. These have the highest chance of damage as they are constantly moving. If any hydraulic components are changed new seals should be installed during reassembly. Fittings should then be retightened.



## TENSION DRIVE BELTS

**NOTE:** There will normally be a rapid drop in tension during run-in period for new belts. When new belts are fitted, check the tension every 2 - 3 hours and adjust until the tension remains constant.

*Belt failures due to lack of correct tensioning will not be covered under your Timberwolf warranty.*

1. Remove side panel.
2. Loosen bolt in centre of tensioner pulley with a 19 mm spanner so that pulley is able to slide with minimal wobble.
3. Turn nut in end of tensioner pulley slider until correct belt tension is achieved. For instructions on checking belt tension & correct belt tension values, please refer to the Timberwolf V-Belt Tensioning Data Table at the end of the manual.
5. Re-tighten bolt in centre of tensioner pulley.
6. Run machine and test, recheck belt tension.
7. **NOTE:** Slack drive belts will cause poor performance and excess belt and pulley wear.

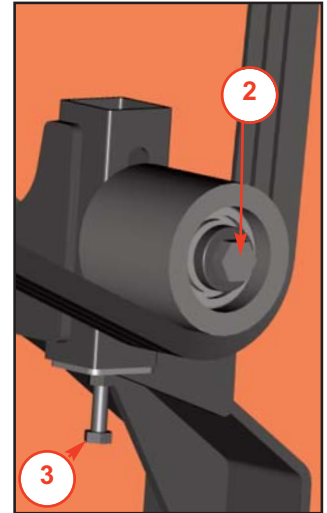

## CHANGE HYDRAULIC OIL AND FILTER

### WARNING

Use plastic gloves to keep oil off skin and dispose of the used oil and filter in an ecologically sound way. The oil and filter should be changed once a year or at any time it becomes contaminated. Before starting, check that the shredder is standing level and brush away loose shreds.



1. Remove the black screw cap from the top of the filter housing (A).
2. Partially remove filter element from inner cup (B). Leave filter to drain for 15 minutes.

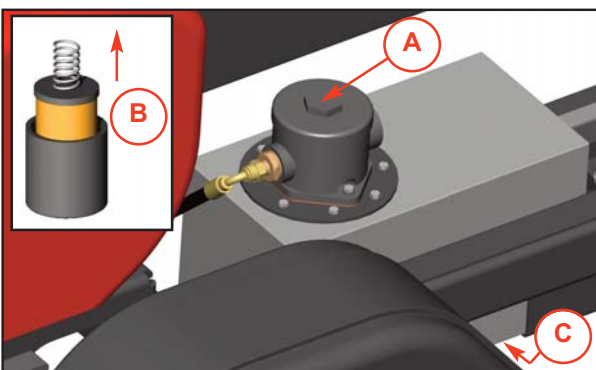

**NOTE:** This is a non-adjustable air breather filter.

3. Remove filter element from cup when clear of hydraulic oil.
4. Remove drain plug (C) and drain oil into a suitable container.
5. Replace drain plug.
6. Refill with VG 32 hydraulic oil until the level is between the min and max lines on the tank (about 15 litres).
7. Refit the filter cup, install a new filter element and refit the black screw cap, to the filter housing, ensuring o-ring remains in place.

## GREASE THE DISCHARGE FLANGE

1. Remove the discharge tube.
2. Apply multipurpose grease to surface shown (A).
3. Refit discharge tube and securely clamp in position.

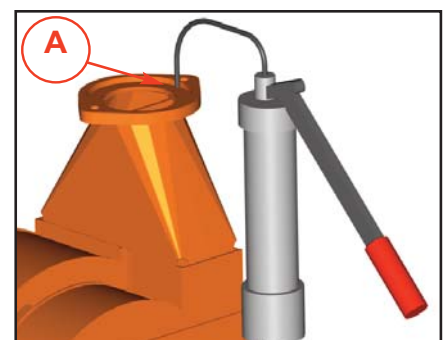



## GREASE THE ROLLER SPLINE AND BEARING

**NOTE:** This should be done regularly. In dirty and dusty conditions or during periods of hard work it should be weekly. If the bearings and splines are allowed to run dry premature wear will occur resulting in a breakdown and the need for replacement parts. This failure is not warranty. Early signs of insufficient grease includes squeaking or knocking rollers.

1. Remove the top roller box guard.
2. Locate the grease nipple indicated (A).
3. Use a pump action grease gun to apply a generous amount of grease to each roller drive.  
**DO NOT USE GRAPHITE BASED GREASE.**
3. Refit the top roller box guard.

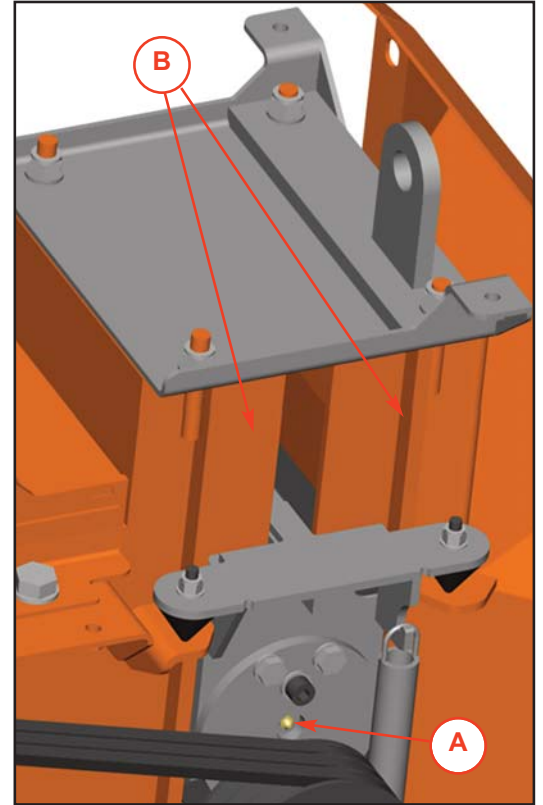

## GREASE THE ROLLER BOX SLIDES

**NOTE:** This should be done every 50 hours. In dirty or dusty conditions or during periods of hard work it should be done more frequently. If the slides become dry the top roller will tend to hang up and the pulling-in power of the roller will be much reduced. Excessive wear will ensue.

1. Remove the top roller box guard.
2. Remove the nearside roller box guard.
3. Apply multipurpose grease directly to the slide surfaces indicated (B). **DO NOT USE GRAPHITE BASED GREASE.**
4. Refit both the roller box guards.

## GREASE THE DRUM BEARINGS

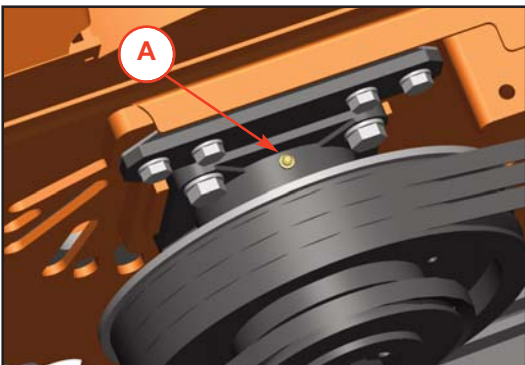

**Both bearings need regularly greasing.**

1. Remove the drum housing guard, situated on the offside of the machine.
  2. Apply two pumps of grease to the bearing (A) taking care not to over grease.
  3. Refit guard.
1. Turn the discharge tube to point forward of the machine.
  2. Using a 24 mm spanner remove the two M16 bolts clamping the drum housing shut.
  3. Carefully lift the drum housing until it rests on its stop.
  4. Apply two pumps of grease (B) to the bearing taking care not to over grease.
  5. Lower the top of the drum housing and reinstall the two M16 bolts.
  6. Torque these to 65lbft.

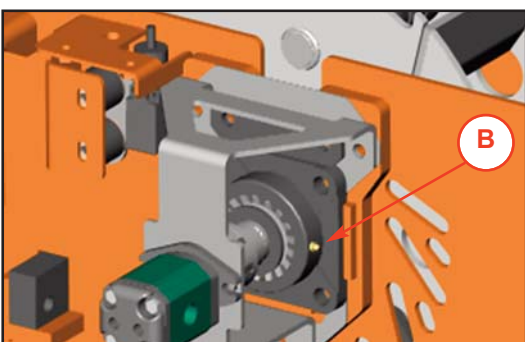





## **ENVIRONMENTAL MANUFACTURING LLP 12 MONTH SHREDDER WARRANTY**

### **WARRANTY PERIOD**

The warranty period for the woodshredder commences on the date of sale to the first end user and continues for a period of 12 months. This guarantee is to the first end user only and is not transferable except when an authorised Timberwolf Dealer has a woodshredder registered with Environmental Manufacturing LLP as a hire shredder or long term demonstrator – in these situations they are duly authorised to transfer any remaining warranty period to their first end user. Any warranty offered by the Timberwolf Dealer beyond the original 12 month period will be wholly covered by said Dealer.

### **LIABILITY**

Our obligation under this warranty is limited to repair at Environmental Manufacturing LLP premises or at our option an Environmental Manufacturing LLP approved Timberwolf dealer. No liability will be accepted for special, indirect, incidental, or consequential loss or damages of any kind.

### **WARRANTY STATEMENT**

Environmental Manufacturing LLP warrants to the first end user that;

-Your woodshredder shall be designed, built and equipped, at the point of sale, to meet all current applicable regulations.

-Your shredder shall be free from manufacturing defects both in materials and workmanship in normal service for the period mentioned above.

Warranty will not apply to a failure where normal use has exhausted the life of a component.

Engine units are covered independently by their respective manufacturer warranties.

### **OWNERS WARRANTY RESPONSIBILITIES**

As the owner of an Environmental Manufacturing LLP woodshredder you are responsible for the following;

-Operation of the woodshredder in accordance with the Environmental Manufacturing LLP instruction manual.

-Performance of the required maintenance listed in your Environmental Manufacturing LLP instruction manual.

-In the event of a failure the Environmental Manufacturing LLP authorised Timberwolf dealer is to be notified within 10 days of failure and the equipment is to be made available for unmolested inspection by the dealer technician.

### **WARRANTY RESTRICTIONS**

The Environmental Manufacturing LLP warranty is restricted to the first end user only and is not transferable except when an authorised Timberwolf Dealer has a woodshredder registered with Environmental Manufacturing LLP as a hire shredder or long term demonstrator – in these situations they are duly authorised to transfer any remaining warranty period to their first end user.

The Environmental Manufacturing LLP warranty may be invalidated if any of the following apply;

-The failed parts or assembly is interfered with in any way.

-Normal maintenance has not been performed.

-Incorrect reassembly of components.

-The machine has undergone modifications not approved in writing by Environmental Manufacturing LLP.

-In the case of tractor driven equipment, use has been on an unapproved tractor.

-Conditions of use can be deemed abnormal.

-The machine has been used to perform tasks contrary to those stated in the Environmental Manufacturing LLP instruction manual.

### **WARRANTY SERVICE**

To obtain warranty service please contact your nearest Environmental Manufacturing LLP approved Timberwolf dealer. To obtain details of the nearest facility please contact Environmental Manufacturing LLP at the address on the front of this manual.

These warranty terms are in addition to and not in substitution for and do not affect any right and remedies which an owner might have under statute or at common law against the seller of the goods under the contract by which the owner acquired the goods.



# CERTIFICATE OF CONFORMITY - DIESEL MODELS

## Environmental Manufacturing LLP

Entec House,  
 Tomo Industrial Estate,  
 Stowmarket,  
 Suffolk IP14 5AY  
 Tel: 01449 765800 Fax: 01449 765801

### E C Declaration of Conformity



Environmental Manufacturing LLP as the designer and manufacturer, certifies that the machine stipulated below complies with all the relevant provisions of the:

### Machinery Directive; 2006/42/EC (& other relevant directives)

and the National Laws and Regulations adopting these directives.

**Designer/Manufacturer** : Environmental Manufacturing LLP  
**Description of Machinery** : Self-powered portable machine intended to shred general green waste.  
**Model** : TW SX200DHB(c) & DHB  
**Serial No.** Serial Manufacture

BSI Transposed Harmonised Standards applied: (including parts/clauses of):

BS EN 12100-1: 2003 Safety of Machinery- Basic concepts, BS EN 13857-1: 2008 Safety of Machinery-Safety distances to danger zones, BS EN 60204-1: 1998 Safe electrical practices, BS EN 13732-1:2006 Safety of Machinery – Temperatures of touchable surfaces, BS EN 13849-1: 2008 – Safety of Machinery – Safety related parts of control systems, BS EN 982: 1996 – Safety of Machinery – Hydraulics, BS EN 1088: 1995 – Safety of Machinery – Interlocking devices, BS EN 13525: 2005 – Forestry Machinery – Wood chippers – Safety.

“Responsible” Person empowered to sign:  Mr. Jeff Haines

Position in Company: Technical Director

Date: 1<sup>st</sup> September 2012



# CERTIFICATE OF CONFORMITY - PETROL MODELS

## Environmental Manufacturing LLP

Entec House,  
Tomo Industrial Estate,  
Stowmarket,  
Suffolk IP14 5AY

Tel: 01449 765800 Fax: 01449 765801

### E C Declaration of Conformity



Environmental Manufacturing LLP as the designer and manufacturer, certifies that the machine stipulated below complies with all the relevant provisions of the:

### Machinery Directive; 2006/42/EC (& other relevant directives)

and the National Laws and Regulations adopting these directives.

Designer/Manufacturer : Environmental Manufacturing LLP  
Description of Machinery : Self-powered portable machine intended to shred general green waste.  
Model : TW SX200 PHB(c) & PHB  
Serial No. : Serial Manufacture

BSI Transposed Harmonised Standards applied: (including parts/clauses of):

BS EN 12100-1: 2003 Safety of Machinery- Basic concepts, BS EN 13857-1: 2008 Safety of Machinery-Safety distances to danger zones, BS EN 60204-1: 1998 Safe electrical practices, BS EN 13732-1:2006 Safety of Machinery – Temperatures of touchable surfaces, BS EN 13849-1: 2008 – Safety of Machinery – Safety related parts of control systems, BS EN 982: 1996 – Safety of Machinery – Hydraulics, BS EN 1088: 1995 – Safety of Machinery – Interlocking devices, BS EN 13525: 2005 – Forestry Machinery – Wood chippers – Safety.



“Responsible” Person empowered to sign:  Mr. Jeff Haines

Position in Company: Technical Director

Date: 1<sup>st</sup> September 2012



# IDENTIFICATION PLATE

		<b>TIMBERWOLF</b> ENVIRONMENTAL MANUFACTURING LLP Entec House, Tomo Industrial Estate, Stowmarket, Suffolk IP14 5AY - UK			
MODEL					
SERIAL NO.					
CARR. TYP/SN.			GROSS WEIGHT		
NOM. PWR			DATE		
					<b>ENVIRONMENTAL MANUFACTURING LLP</b>
					0 - KG
					1 - KG
					2 - KG

EXAMPLE

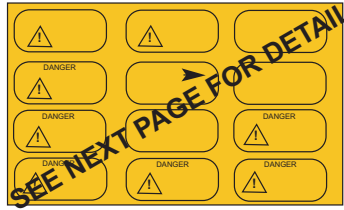

616                      617                      670                      671                      1258                      1363

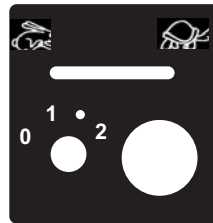
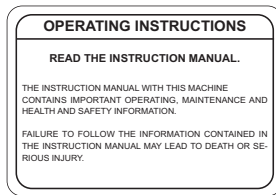

**TIMBERWOLF**

1522                      1661                      1662                      1756                      2641

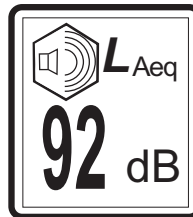
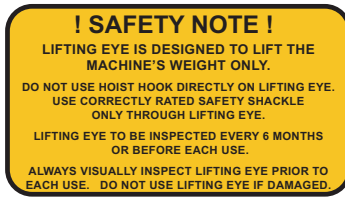
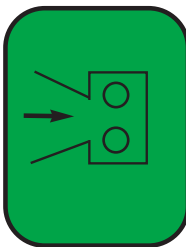
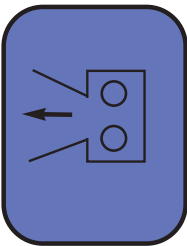

2800 X 2                      2801 X 2                      2949                      3004                      4114



4099 X 2                      4138                      17861 X 2                      18393                      18438

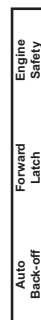

**TW SX200PHB(C)**









**TW SX200DHB(C)**

18713                      18714                      18774                      19517                      P\*142 x 2 P\*350 x 2





671 - these individual decals are supplied as a set, they may not all apply to your machine.

<p><b>DANGER</b></p>  <p>DO NOT OPERATE WITHOUT THIS COVER IN PLACE</p>	<p><b>DANGER</b></p>  <p>AUTOFEED SYSTEM FITTED. ROLLERS MAY TURN WITHOUT WARNING! WHEN ENGINE IS SWITCHED OFF THE ROLLERS WILL TURN DURING THE RUN DOWN PERIOD</p>	<p><b>CAUTION</b></p> <p>WHEN TRANSPORTING DISCHARGE CLAMPS MAY WORK LOOSE. CHECK FREQUENTLY</p>
<p><b>DANGER</b></p>  <p>DO NOT OPERATE WITHOUT THIS COVER IN PLACE</p>	<p>FUEL HERE </p> <p>RISK OF FIRE</p> <p>ALLOW ENGINE TO COOL FOR 1 MINUTE BEFORE REFUELING. USE UNLEADED PETROL</p>	<p><b>CAUTION</b></p> <p>AVOID STANDING DIRECTLY IN FRONT OF FEED FUNNEL TO REDUCE EXPOSURE TO NOISE, DUST AND RISK FROM EJECTED PARTICLES</p>
<p><b>DANGER</b></p>  <p>DO NOT OPERATE WITHOUT THIS COVER IN PLACE</p>	<p><b>CAUTION</b></p> <p>DO NOT PUT ROAD SWEEPINGS IN MACHINE AS GRIT WILL DAMAGE BLADES</p>	<p><b>DANGER</b></p>  <p>ROTATING BLADES</p>
<p><b>DANGER</b></p>  <p>DO NOT OPERATE WITHOUT THIS COVER IN PLACE</p>	<p><b>DANGER</b></p>  <p>STOP ENGINE AND REMOVE KEY BEFORE REMOVING DISCHARGE UNIT. ROTATING BLADES INSIDE.</p>	<p><b>DANGER</b></p>  <p>DO NOT USE THIS MACHINE WITHOUT THE DISCHARGE UNIT FITTED FAILURE TO COMPLY MAY RESULT IN SERIOUS INJURY OR DAMAGE</p>

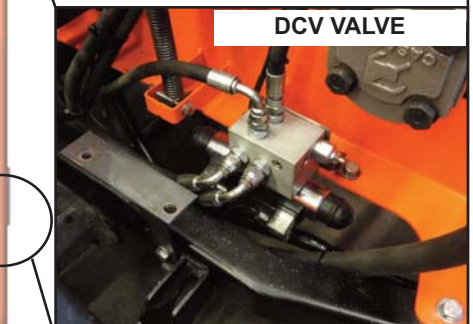
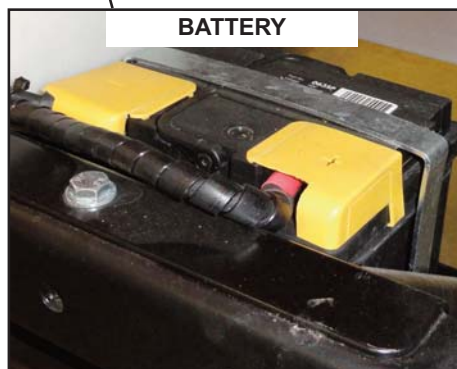
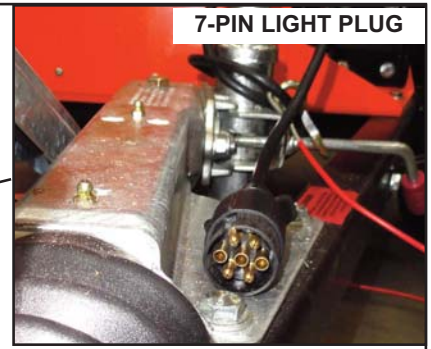
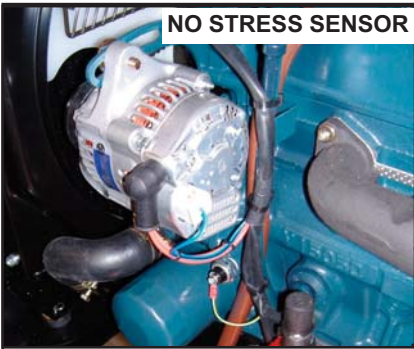





NO STRESS SENSOR

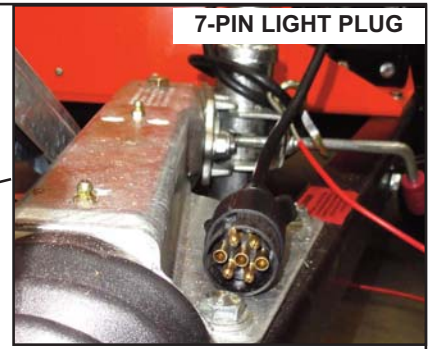

7-PIN LIGHT PLUG



ELECTRIC STARTER

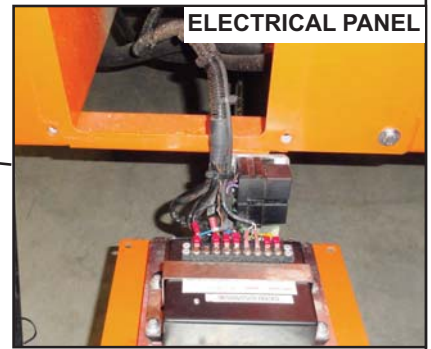

ELECTRICAL PANEL



LOOM JUNCTION



DRUM HOUSING  
SAFETY SWITCH



FUNNEL SAFETY SWITCHES

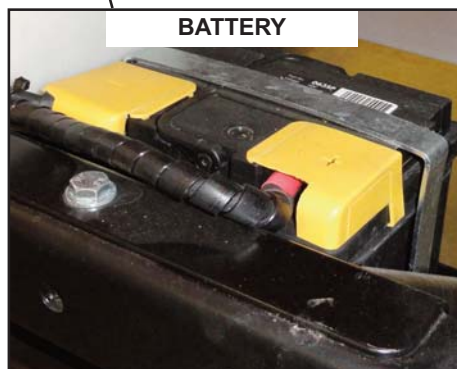

BATTERY

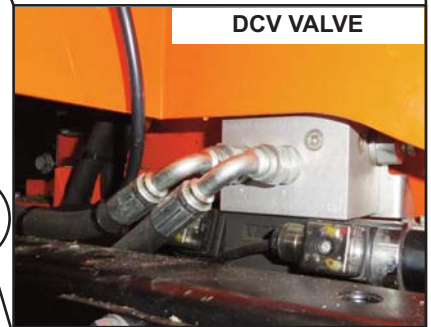

DCV VALVE



CONTROL BOX

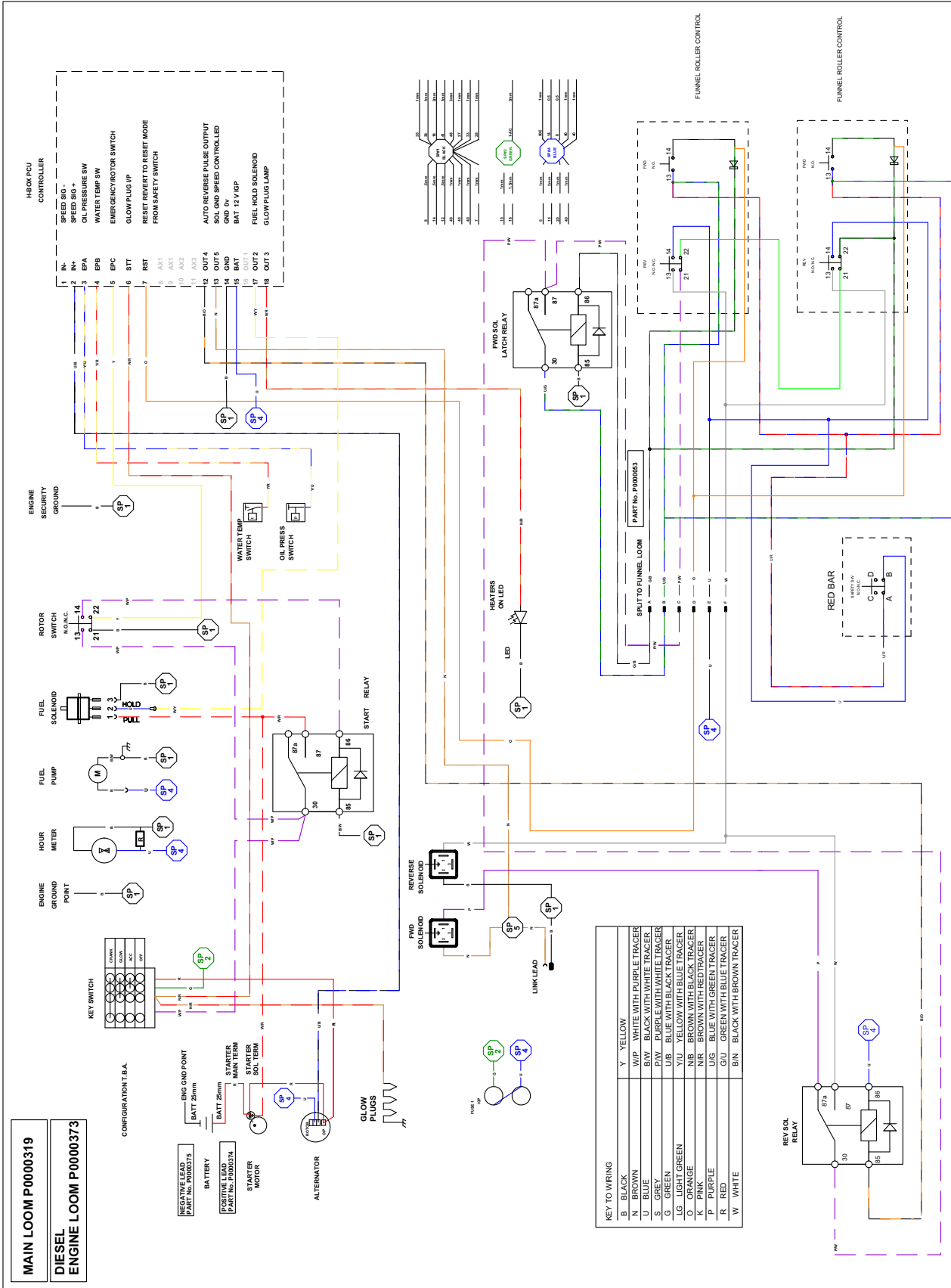

DOCUMENT No. **SX200 DIESEL-CD** 1

**CIRCUIT DIAGRAM FOR: SX200 DIESEL**

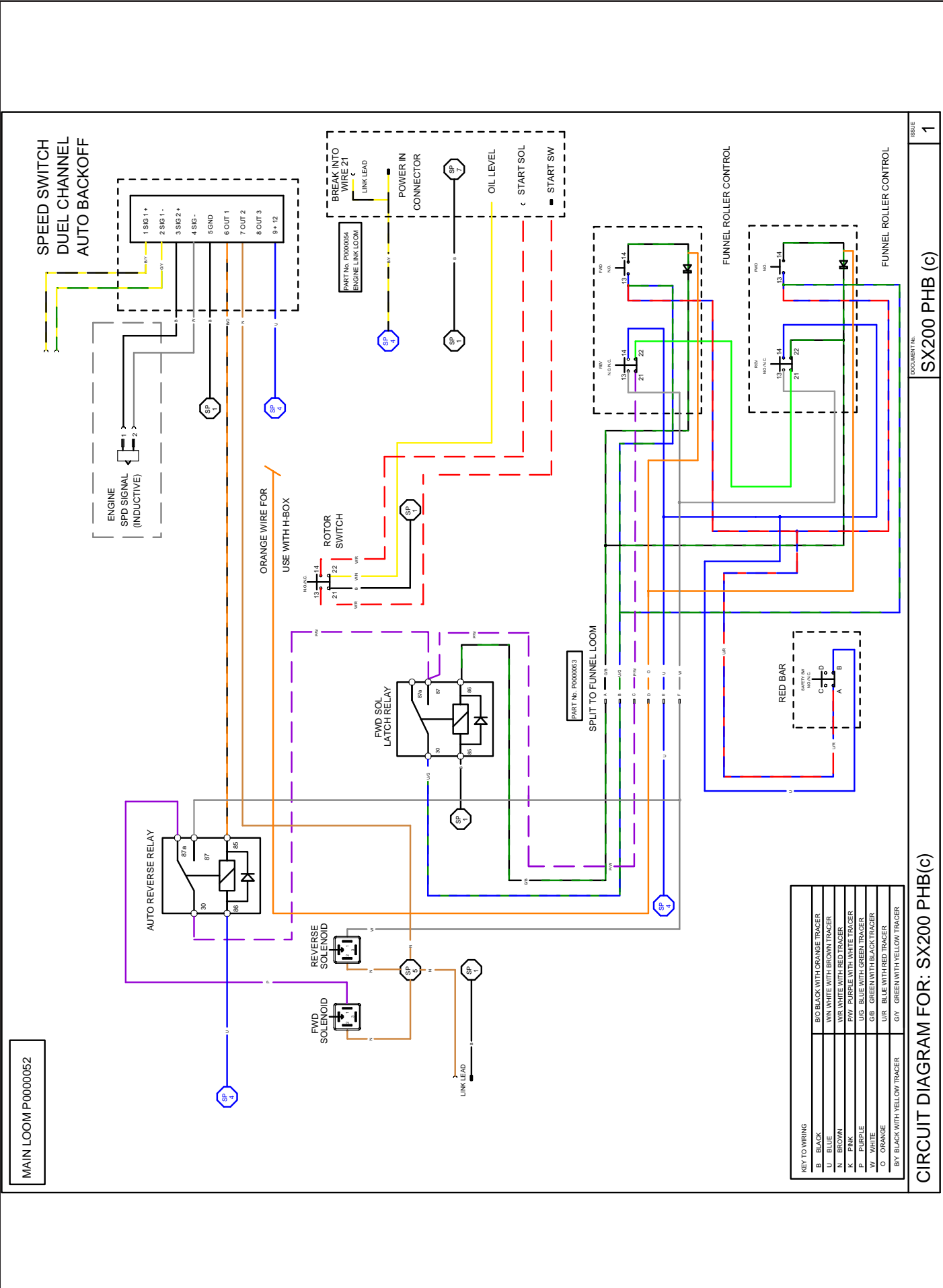



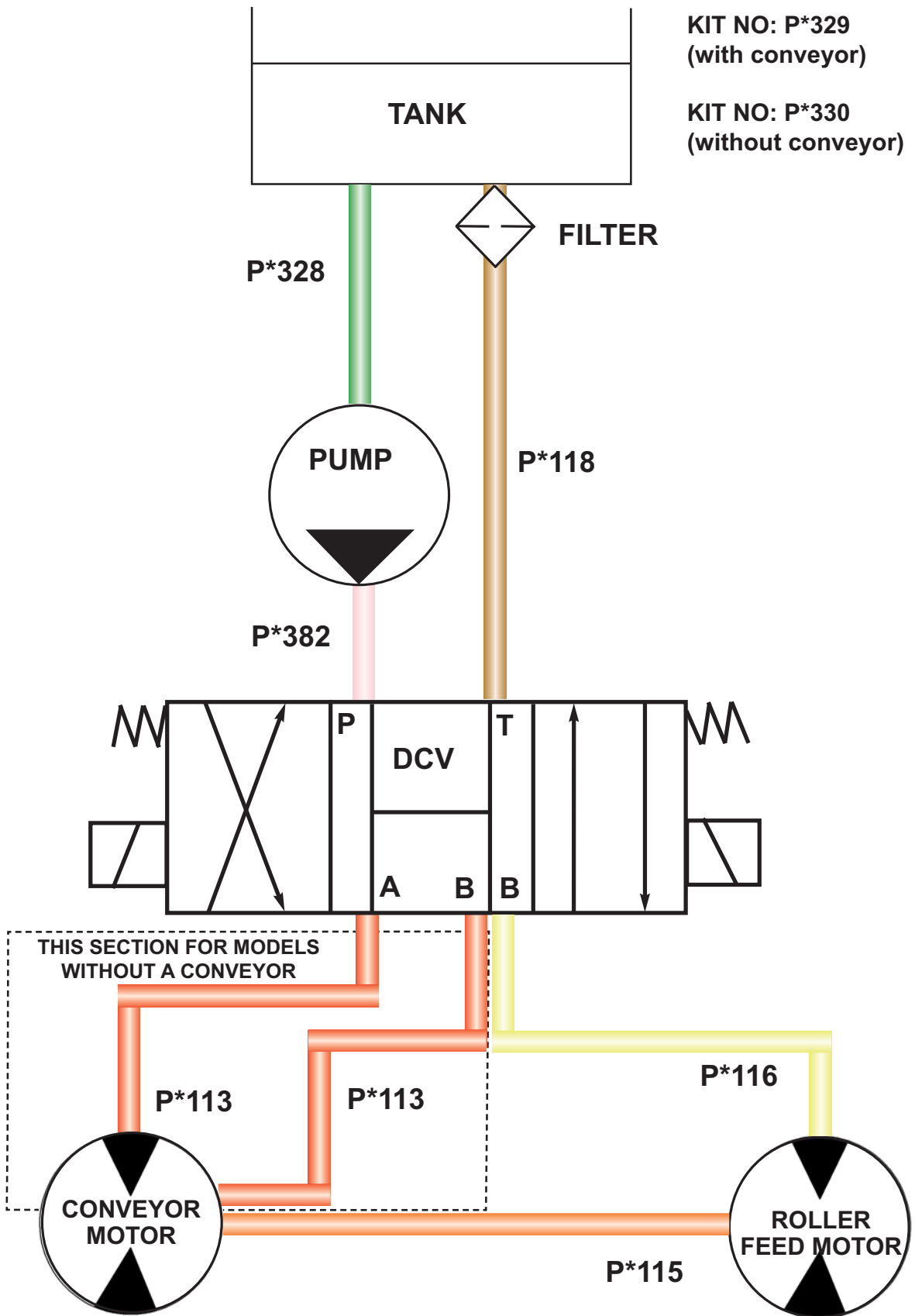

(Blank page)



# PARTS LISTS

*The following illustrations are for parts identification only. The removal or fitting of these parts may cause a hazard and should only be carried out by trained personnel.*

	<i>Page No.</i>
<b>BELT TENSIONER</b>	<b>37</b>
<b>CHASSIS (1)</b>	<b>38</b>
<b>CHASSIS (2)</b>	<b>39</b>
<b>CONTROL BOX</b>	<b>40</b>
<b>CONTROL PANEL</b>	<b>41</b>
<b>CONVEYOR</b>	<b>42</b>
<b>DECALS</b>	<b>See pages 28 - 29</b>
<b>DISCHARGE</b>	<b>43</b>
<b>DRIVE TRAIN</b>	<b>44</b>
<b>DRUM</b>	<b>45</b>
<b>DRUM HOUSING</b>	<b>46</b>
<b>ELECTRICAL LAYOUT</b>	<b>47</b>
<b>ELECTRICAL PANEL</b>	<b>48</b>
<b>ENGINE (DIESEL)</b>	<b>49</b>
<b>ENGINE (PETROL)</b>	<b>50</b>
<b>FUEL TANK</b>	<b>51</b>
<b>FUNNEL</b>	<b>52</b>
<b>GUARDS</b>	<b>53</b>
<b>HYDRAULICS</b>	<b>54</b>
<b>ROLLER</b>	<b>55</b>
<b>V- BELT TENSIONING TABLE</b>	<b>56</b>

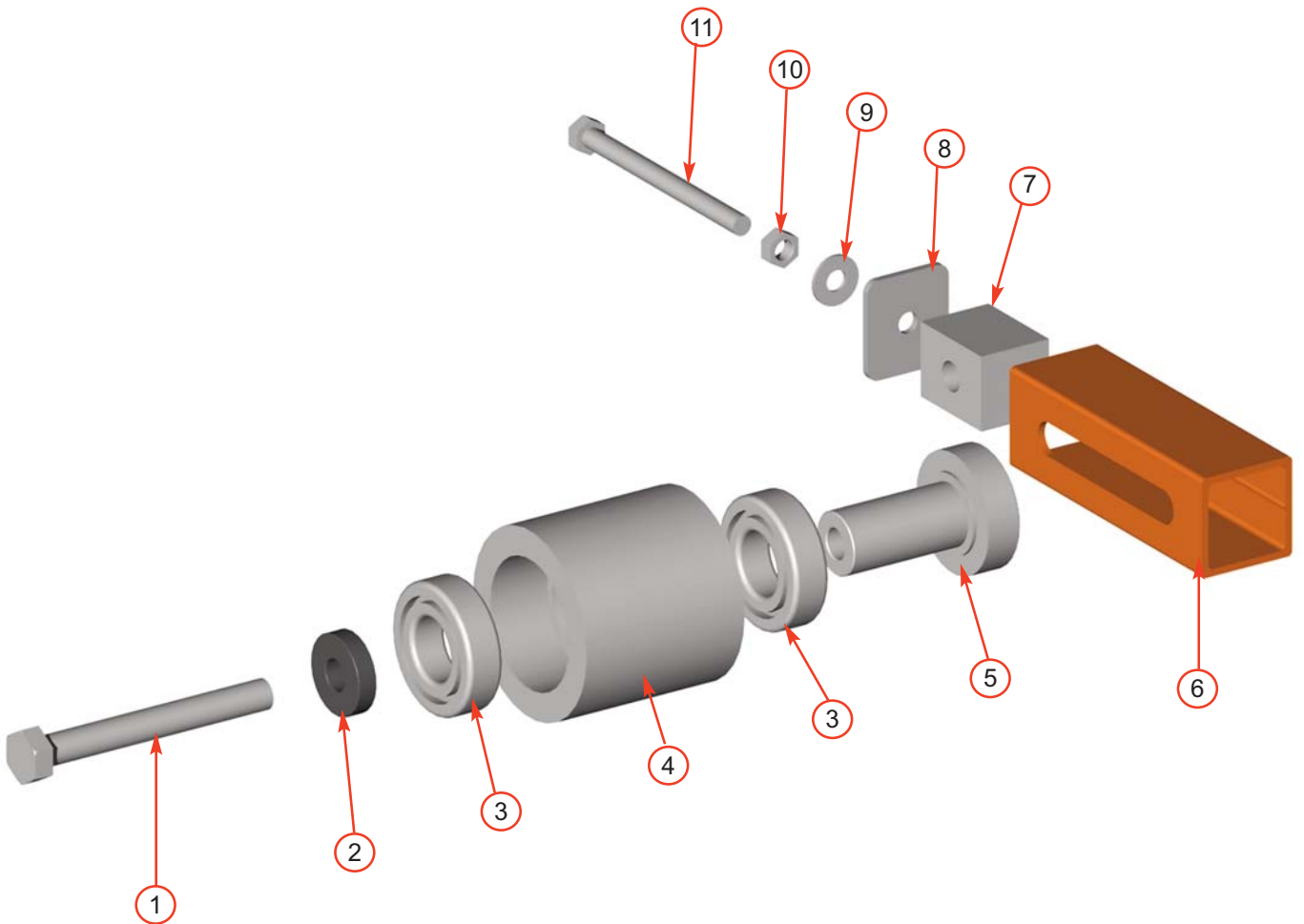

Item	Part No	Part Name	Q'ty
1	0313	M12/100 Bolt	1
2	0415	Heavy Washer	1
3	0491	Bearing 6205	2
4	0411M	Pulley	1
5	0472M	Pulley Boss	1
6	<i>N/A to purchase</i>	Slider	1
7	0469MS	Slider Block	1
8	1342PS	End Plate	1
9	<i>made in production</i>	Washer	1
10	0476	Plain M8 Nut	1
11	2988	M8/90 Bolt	1

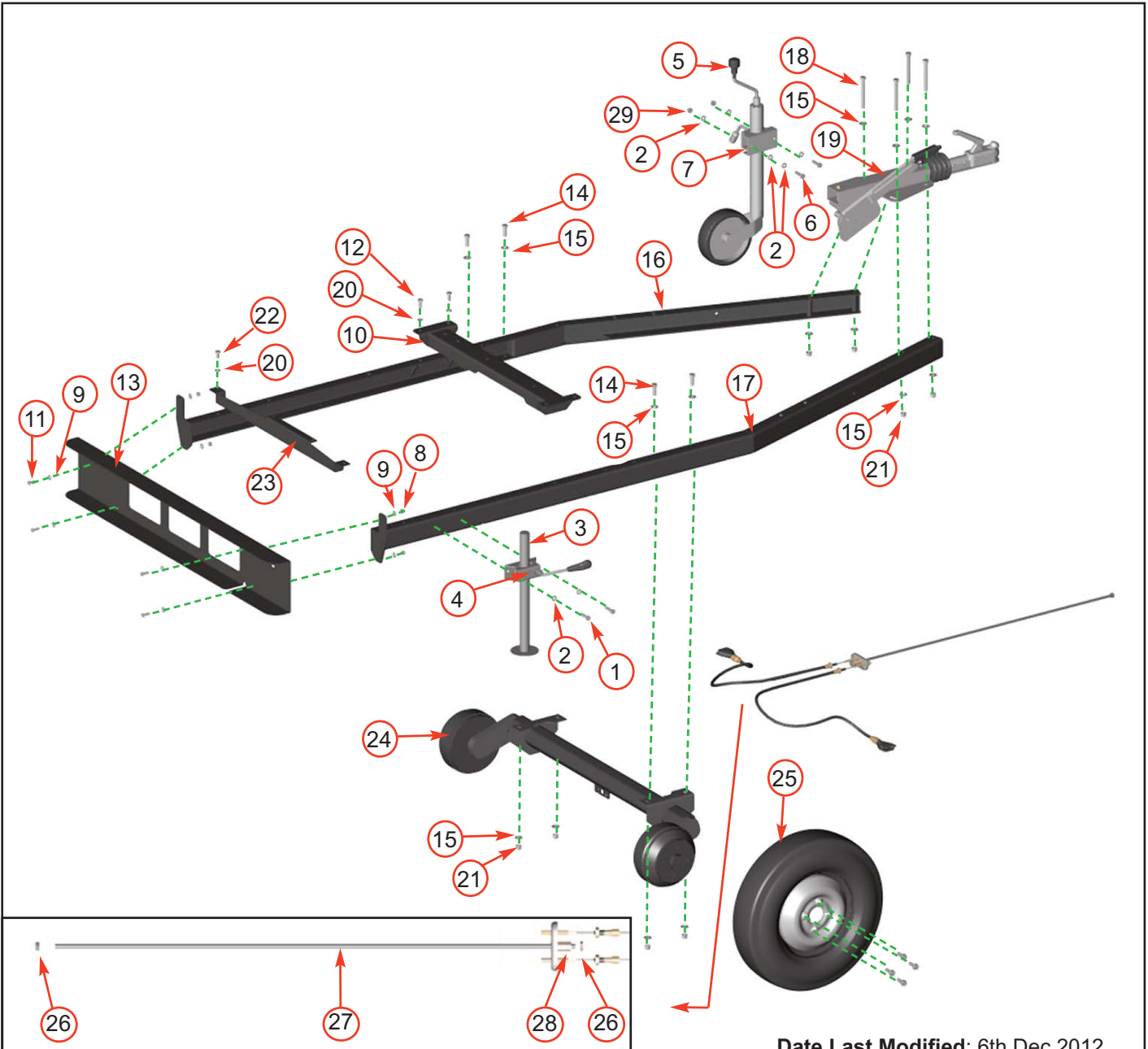

Date Last Modified: 6th Dec 2012

Item	Part No	Part Name	Q'ty	Item	Part No	Part Name	Q'ty
1	0360	M10/25 Bolt	2	16	P*46	Beam N/S	1
2	0701	M10 A Washer	7	17	P*47	Beam O/S	1
3	0012	Prop Stand	1	18	0314	M12/110 Bolt	4
4	0017	34 mm Prop Clamp	1	19	P*74	Tow Head	1
5	P*75	Jockey Wheel Assy	1	20	0839	M10 C Washer	6
6	0382	M10/30 Bolt	2	21	0644	M12 P Nyloc Nut	8
7	18083	Jockey Wheel Clamp	1	22	0878	M10/20 Bolt	2
8	0479	M8 P Nyloc Nut	4	23	P*57	Rear Funnel Support	1
9	0712	M8 C Washer	4	24	P*73	Axle	1
10	P*48	Chassis Brace	1	25	19663	Wheel	2
11	0350	M8/25 Bolt	4	26	1036	M10 Plain Nut	2
12	0360	M10/25 Bolt	4	27	4010	Brake Rod	1
13	P*45	Lightboard Bracket	1	28	0079F	Nut Ball	1
14	0429	M12/35 Bolt	4	29	4345	M10 P Nyloc Nut	2
15	0704	M12 C Washer	20				



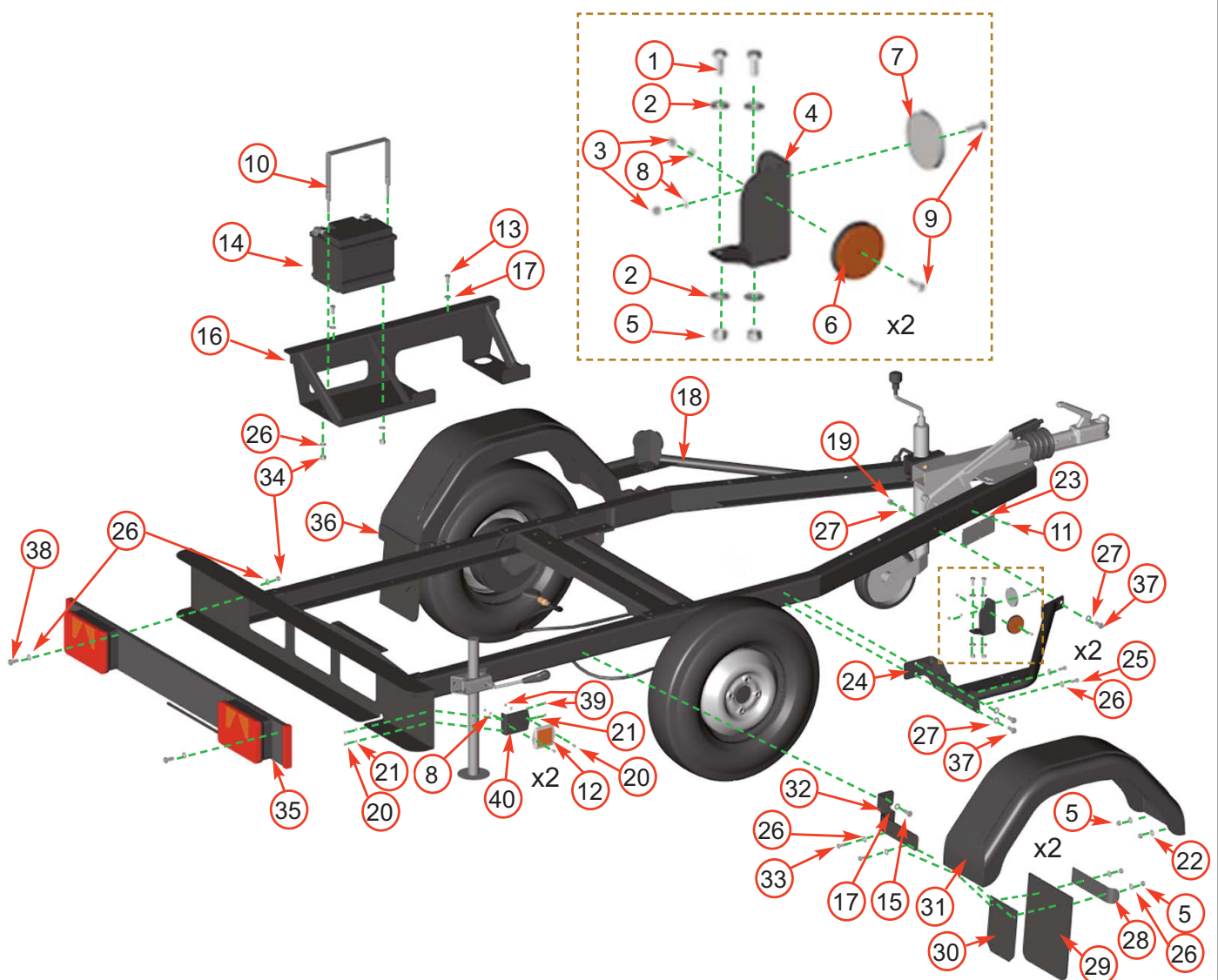

Date Last Modified: 10th Jan 2013

Item	Part No	Part Name	Q'ty	Item	Part No	Part Name	Q'ty
1	0346	M8/20 Bolt	4	21	0708	M5 C Washer	8
2	0711	M8 A Washer	8	22	0714	M8 Mudguard Washer	4
3	0236	M5 P Nyloc Nut	4	23	19600	ID Plate	1
4	18919	Reflector Support Bracket	2	24	P*36	Anti Trap Bar O/S	1
5	0481	M8 P Nyloc Nut	12	25	0350	M8/25 Bolt	4
6	18923	Reflector Amber	2	26	0712	M8 C Washer	18
7	18922	Reflector Clear	2	27	0701	M10 A Washer	8
8	0857	M5 A Washer	8	28	19681	Rain Flap Clamp	2
9	0856	M5/20 Pan Pozi	4	29	19691	Rain Flap	2
10	17776FS	Battery Strap	1	30	19689	Rain Flap Support	2
11	0067	Pop Rivet 4.8 x 12	4	31	19664	Mudguard	2
12	18924	Reflector Square Side	2	32	19655	Rear Mudguard Bracket O/S	1
13	0878	M10/20 Bolt	2	33	18117	M8/35 Bolt	4
14	4210	Battery	1	34	0479	M8 P Nyloc Nut	4
15	0360	M10/25 Bolt	4	35	19792	Lightboard	1
16	P*67	Battery Tray	1	36	19654	Rear Mudguard Bracket N/S	1
17	0839	M10 C Washer	4	37	0382	M10/30 Bolt	2
18	P*35	Anti Trap Bar N/S	1	38	0352	M8/40 Bolt	2
19	4345	M10 P Nyloc Nut	2	39	18102	M5 T Nyloc Nut	8
20	18104	M5/12 Pan Pozi	8	40	P*176	Reflector Bracket	2

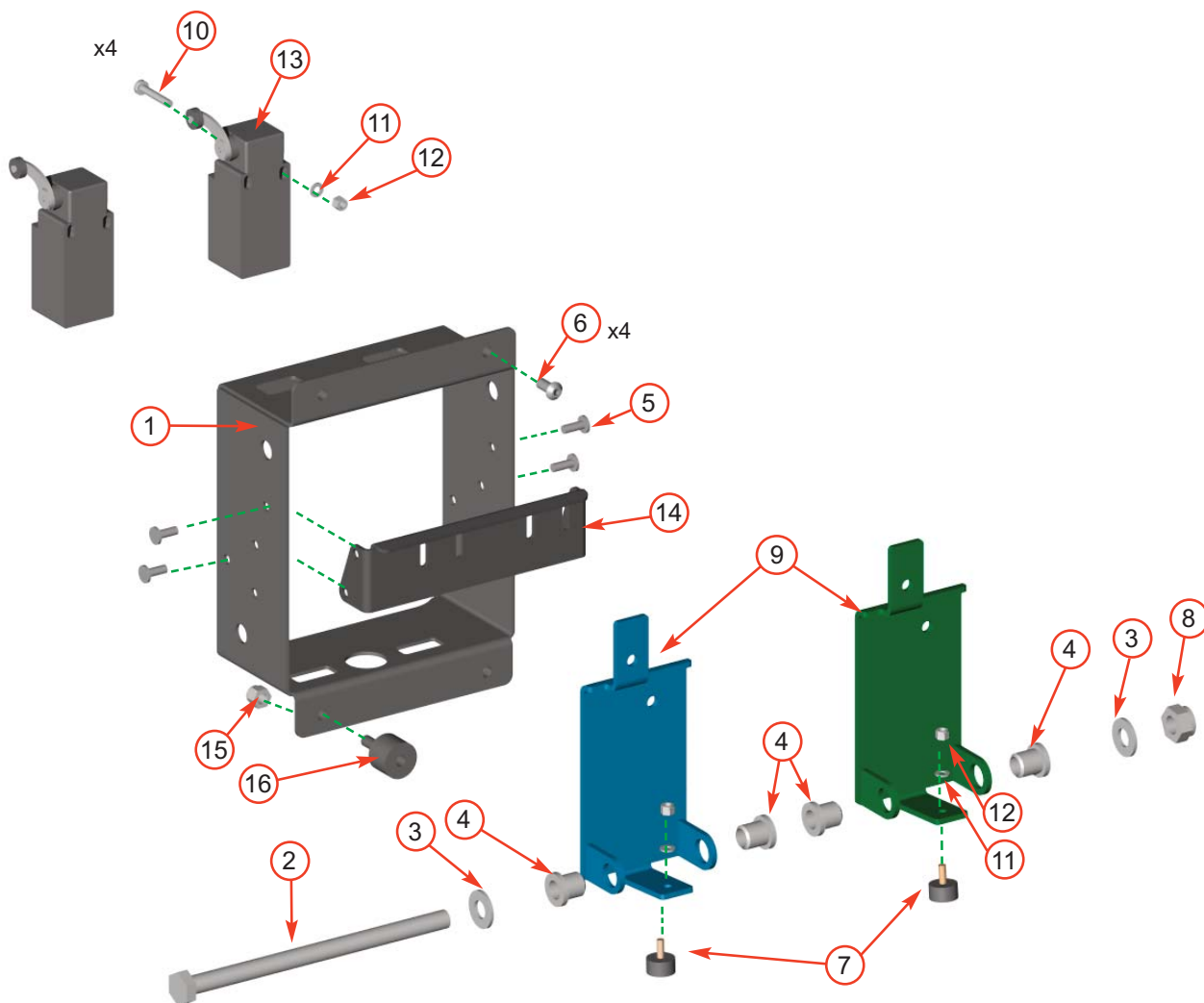

Date Last Modified: 6th Dec 12

Item	Part No	Part Name	Q'ty	Item	Part No	Part Name	Q'ty
1	17802FB	Control Box Cover	1	9	17803FS	Finger Plate	2
2	17963	M10/160 Bolt	1	10	18168	M4/35 Pan Pozi	4
3	0839	M10 C Washer	2	11	18100	M4 Washer	6
4	2804	Bush M10 Top Hat	4	12	18235	M4 P Nyloc Nut	6
5	0067	Pop Rivet M5/12	4	13	17927	Limit Switch	2
6	18108	M6/8 Pan Pozi	4	14	17805FS	Switch Mounting Plate	1
7	2834	AV Mount VE Type	2	15	0142	M6 P Nyloc Nut	4
8	4345	M10 P Nyloc Nut	1	16	18000	AV Mount	4

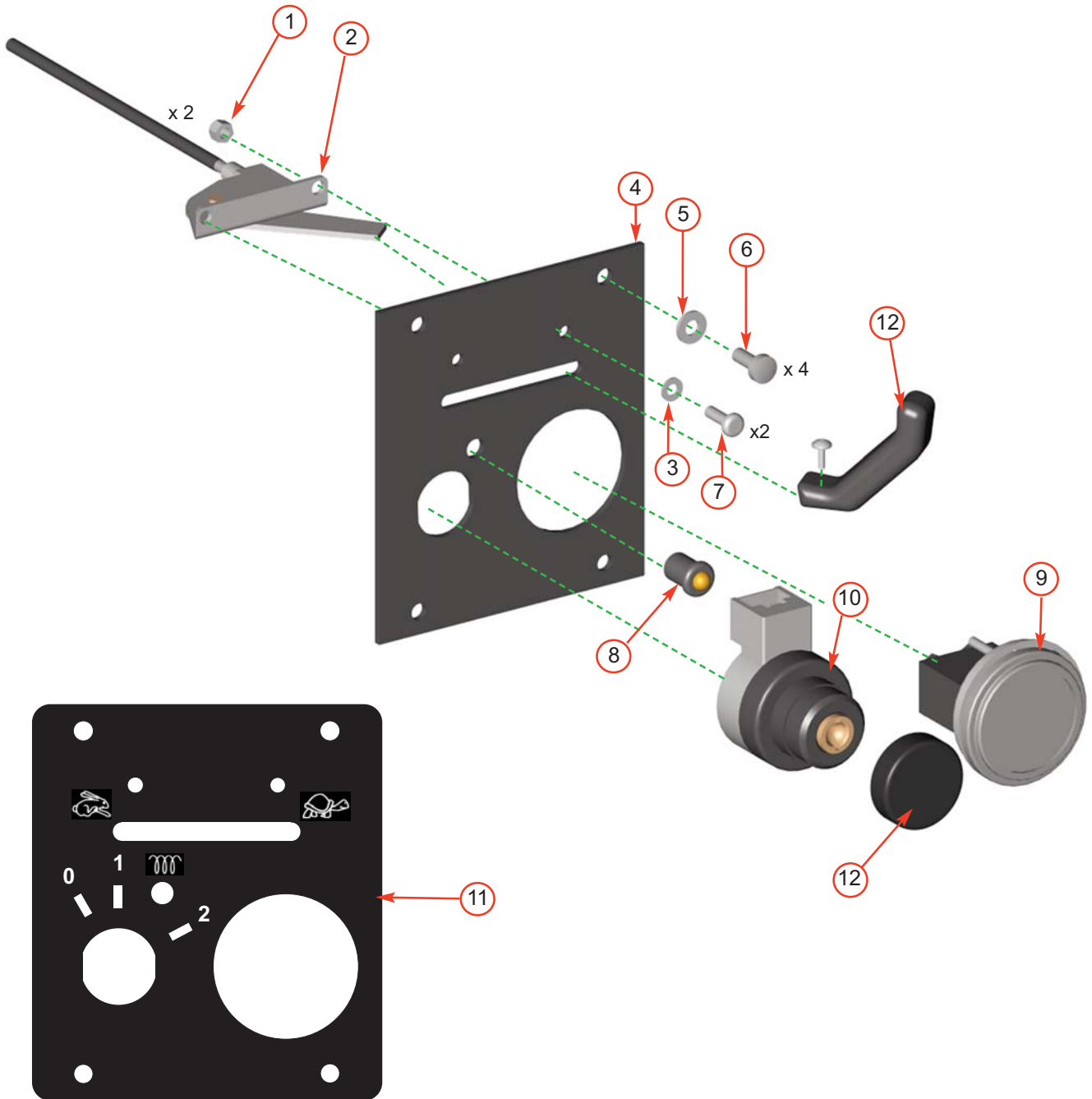

Date Last Modified: 9th July 10

Item	Part No	Part Name	Q'ty	Item	Part No	Part Name	Q'ty
1	0236	M5 P Nyloc Nut	2	8	1757	Amber LED	1
2	0911	Throttle Cable	1	9	0327	Hours Counter	1
3	0708	M5 C Washer	2	10	Supp'd with engine	Ignition Switch	1
4	1758S	Control Panel	1	11	1756	Control Panel Decal	1
5	0709	M6 C Washer	4	12	1397	Throttle Lever	1
6	0438	M6/16 Pan Pozi	4	13	1470	Rubber Protector	1
7	0435	M5/16 Pan Pozi	4				

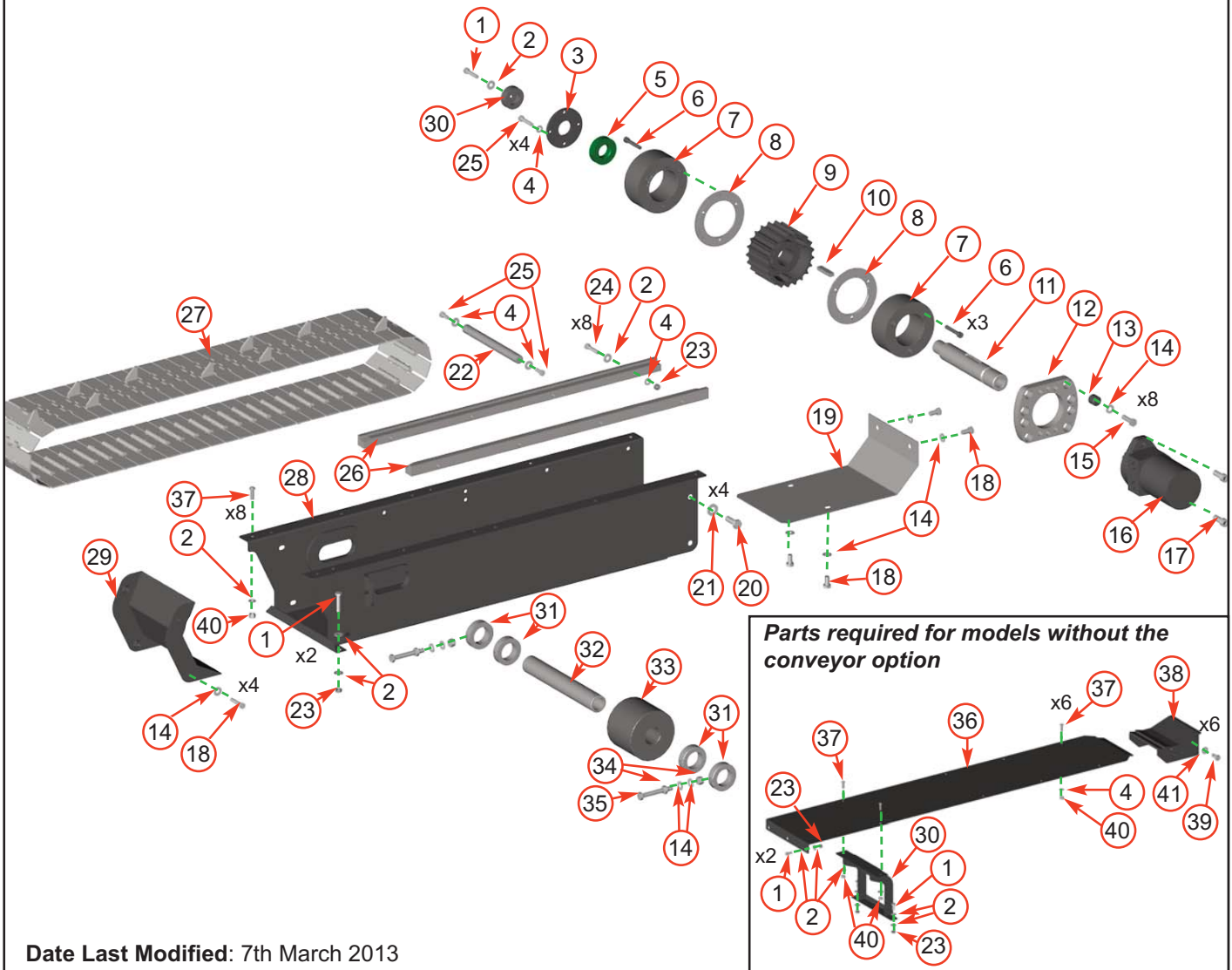

Date Last Modified: 7th March 2013

Item	Part No	Part Name	Q'ty	Item	Part No	Part Name	Q'ty
1	0346	M8/20 Bolt	7	22	P*80	Pivot Pin	1
2	0712	M8 C Washer	31	23	0481	M8 T Nyloc Nut	14
3	P*66	Conveyor Support Cap Plate	1	24	0352	M8/40 Bolt	8
4	0711	M8 A Washer	12	25	0344	M8/16 Bolt	6
5	0788	Bearing Plastic (Oilon) Bush	1	26	P*189	Slat Runner	2
6	18115	M8/50 Caphead	6	27	P*94	Conveyor	1
7	P*172	Conveyor Front Wheel	2	28	P*186	Conveyor Base Tray	1
8	P*171	Sprocket Ring	2	29	P*187	Conveyor Rear Bracket	1
9	P*170	Conveyor Sprocket Machined	1	30	P*145	Drive Shaft Spacer	1
10	P*169	12x8x50 Key	1	31	P*70	Shaft Collar 40mm dia	4
11	P*173	Conveyor Drive Shaft	1	32	P*63	Conveyor End Shaft	1
12	3025MS	Bracket Motor Av Mount 190	1	33	P*190	Rear Slat Roller	1
13	3026	Av Bush Concentric M10 23Mm	8	34	1036	M10 Plain Nut	2
14	0839	M10 C Washer	20	35	0342	M10/100 Bolt	4
15	P*174	M10/35 Fine Hex Set Screw	8	36	P*	Funnel Blanking Plate	1
16	2982B	Motor	1	37	0347	M8/20 Button Head	8
17	1985	M12/30 Caphead	2	38	P*194	Roller Dead Plate	1
18	0878	M10/20 Bolt	8	39	0321	M12/30 Bolt	6
19	P*188	Conveyor Front Plate	1	40	0479	M8 P Nyloc Nut	10
20	0277	M12/25 Bolt	4	41	0702	M12 A Washer	6
21	0704	M12 C Washer	4				

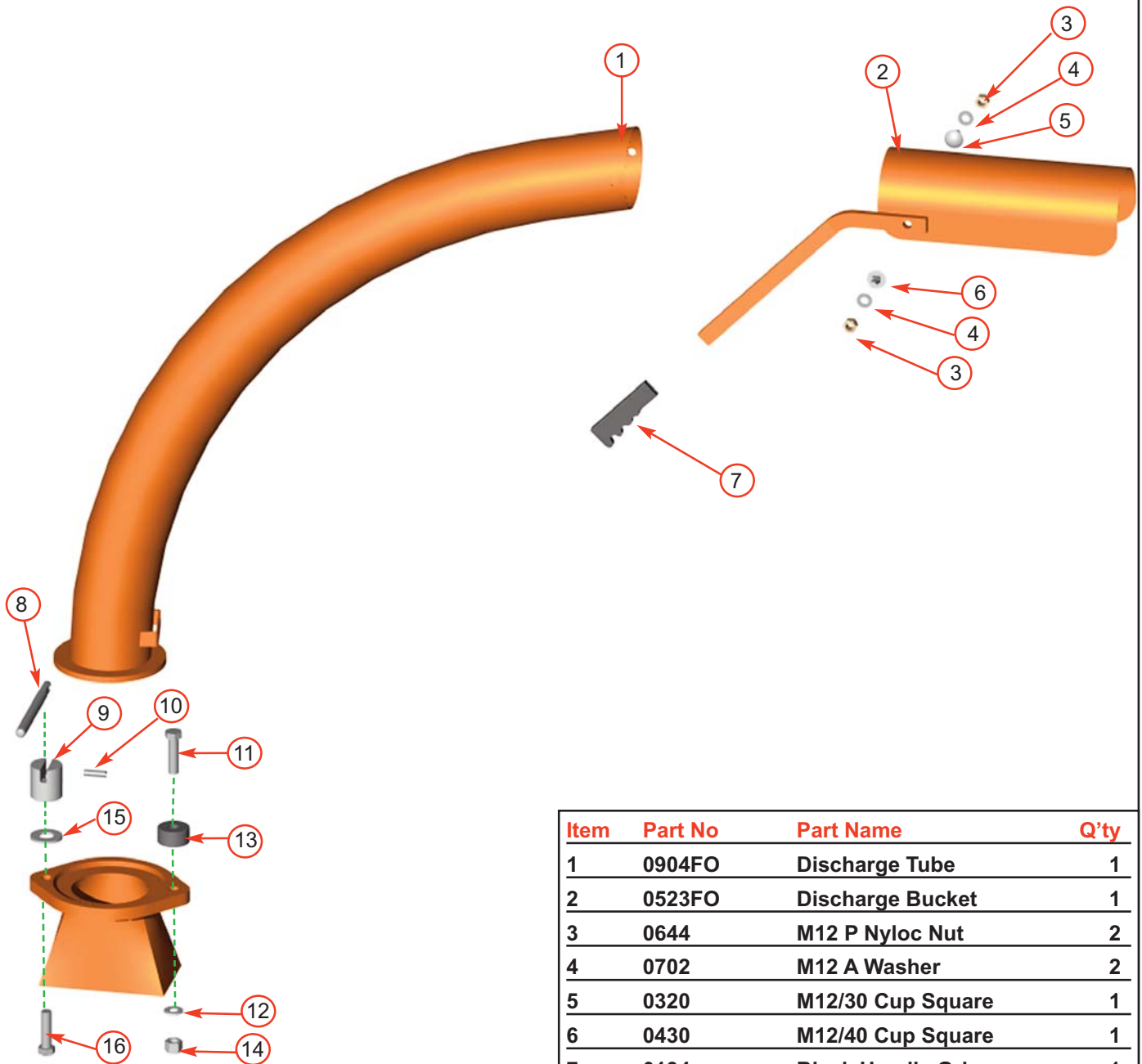

Item	Part No	Part Name	Q'ty
1	0904FO	Discharge Tube	1
2	0523FO	Discharge Bucket	1
3	0644	M12 P Nyloc Nut	2
4	0702	M12 A Washer	2
5	0320	M12/30 Cup Square	1
6	0430	M12/40 Cup Square	1
7	0134	Black Handle Grip	1
8	1649MS	Discharge Clamp Handle	1
9	4109M	M16 Clamp Nut	1
10	4131	Roll Pin	1
11	0434	M16/70 Hex Bolt	1
12	1354	M16 C Washer	1
13	2837M	Clamp Nut Small	1
14	1511	M16 P Nyloc Nut	1
15	0832	M24 Washer	1
16	0333	M16/60 Hex Bolt	1



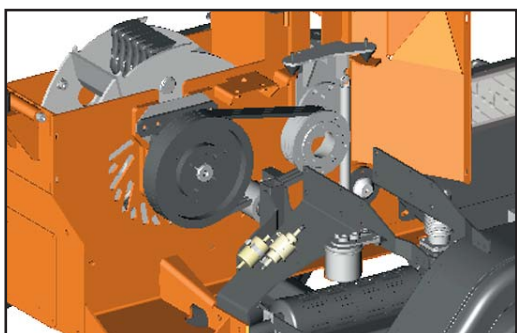
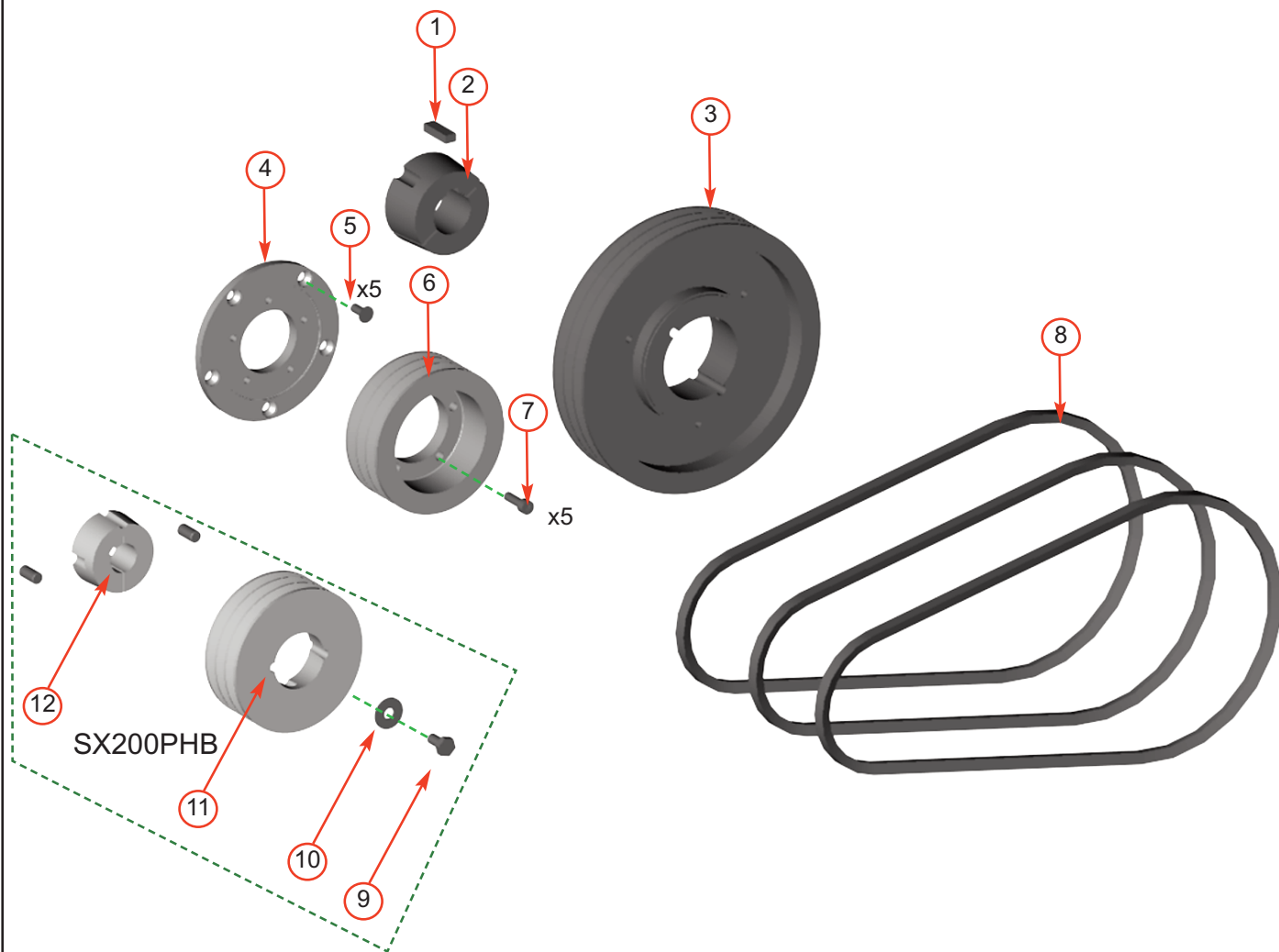

Date Last Modified: 31st May 2013

Item	Part No	Part Name	Q'ty	Item	Part No	Part Name	Q'ty
1	P*86	Key 12 x 8 x 35mm	1	7	0372	M8/20 Caphead	5
2	P*85	Taperlock Bush 2517	1	8	17322	Belt SPA 1232	3
3	2735	Pulley 250 x 3 SPA Machined	1	9	17283	Long Socket Head Screw	1
4	P*286	Engine Pulley Adaptor	1	10	4344	M10/30 Washer	1
5	0348	M8/20 CSK Screw	5	11	0444	Pulley 132 X 3 SPA	1
6	P*285	Diesel Engine Pulley	1	12	0408	Bush 2012 1"	1

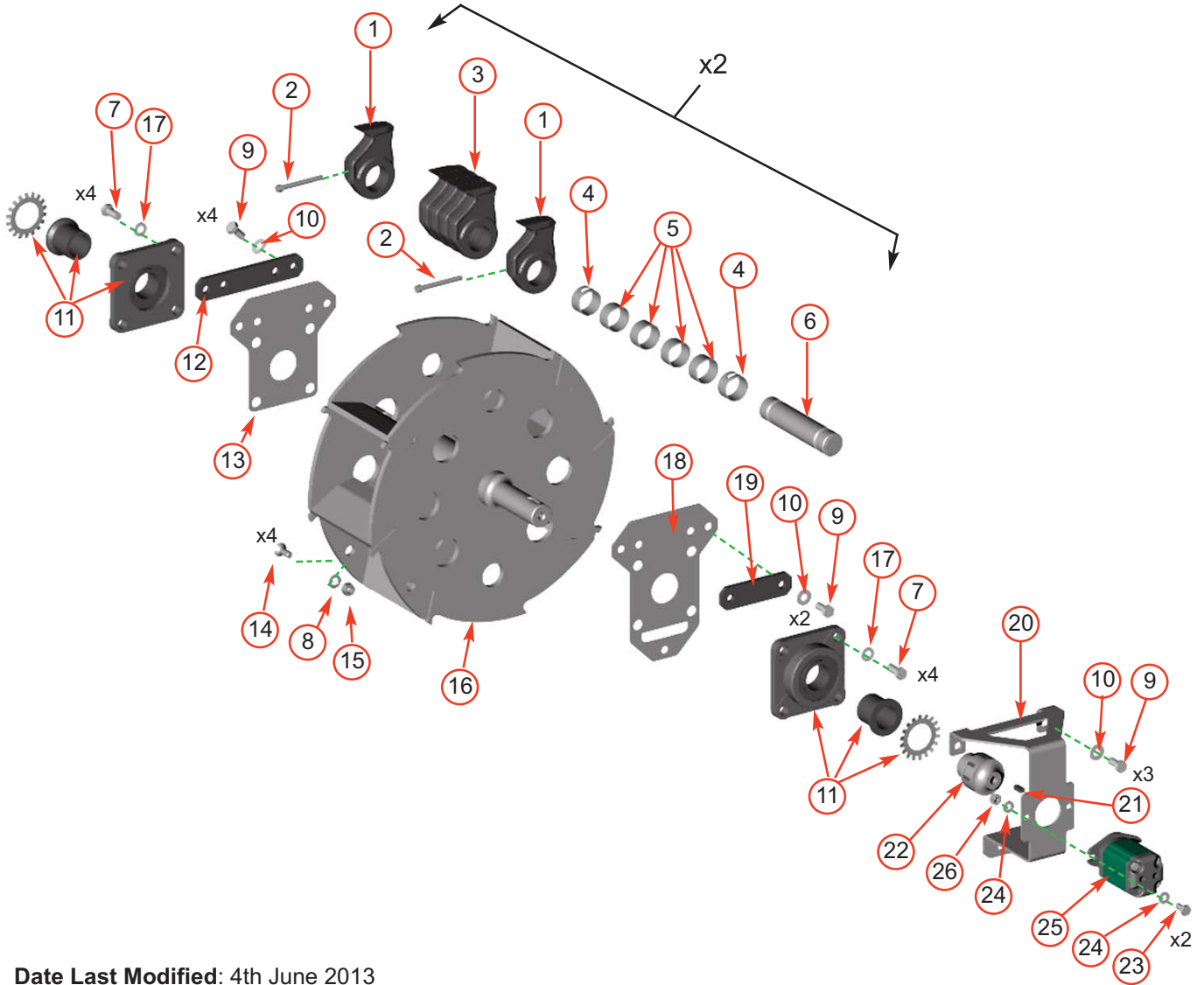

Date Last Modified: 4th June 2013

Item	Part No	Part Name	Q'ty	Item	Part No	Part Name	Q'ty
1	P*27	Mini Hammer - Cross Drilled	4	12	P*72	Brace Bar Plated	1
2	P*22	M8/80 Socket Head Cap Screw	4	15	0045	M12 T Nyloc Nut	4
3	P*26	Mini Hammer - Plain	8	16	P*32	Drum	1
4	P*28	Mini Hammer Bush Slotted	4	17	P*165	M14 Hardened Washer	8
5	P*29	Mini Hammer Bush Plain	8	18	P*320	Extended Bearing Shield	1
6	P*30	Mini Hammer Shaft - Short	2	19	P*321	Brace Bar Short	1
7	P*164	M14 x 1.5p x 40 long hex set bolt	8	20	P*322	Pump Bracket	1
8	18087	M12 Hardened Washers	4	21	P*325	Drive Coupling Key (8 x 7 x 20)	1
9	0277	M12/25 Bolt	11	22	P*323	Drive Coupling	1
10	0704	M12 C Washer	11	23	0878	M10/20 Bolt	2
11	P*55	Bearing Ø40 UKF 209& Adapter Sleeve	2	24	0701	M10 A Washer	4
13	P*49	Bearing Shield Plated	1	25	P*59	Hydraulic Pump 6.3cc	1
14	0428	M12/30 CSK Patchhead	4	26	0052	M10 T Nyloc Nut	2

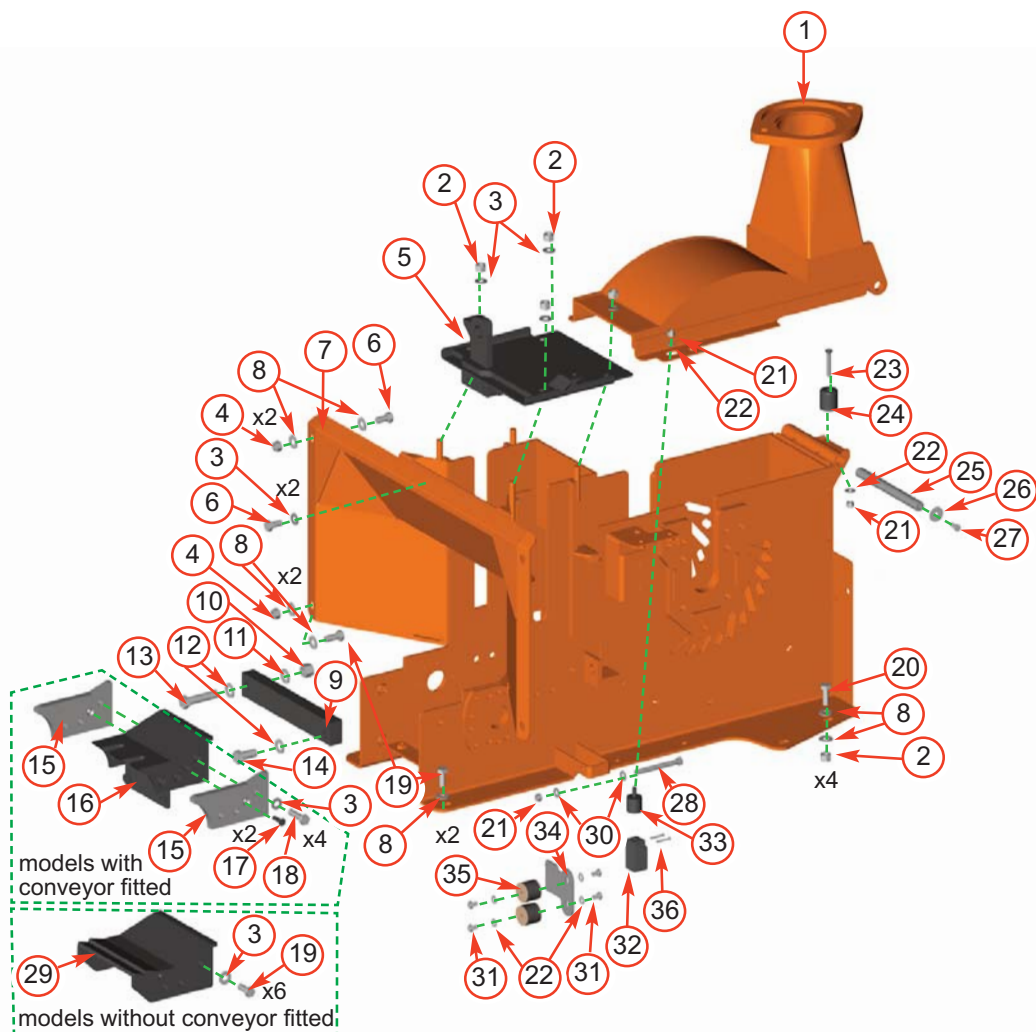

Date Last Modified: 5th June 2013

Item	Part No	Part Name	Q'ty	Item	Part No	Part Name	Q'ty
1	P*308	Top Drum Housing	1	19	0321	M12/30 Bolt	10
2	0644	M12 P Nyloc Nut	8	20	0429	M12/35 Bolt	4
3	0702	M12 A Washer	13	21	0479	M8 P Nyloc Nut	4
4	0045	M12 T Nyloc Nut	3	22	0712	M8 C Washer	6
5	P*327	Top Plate inc Lifting Lug	1	23	P*197	M8/55 Skt Csk Z/P	1
6	0277	M12/25 Bolt	4	24	4206	Bush Nylon For Control Bar Stop	1
7	P*326	Main Base Drum Housing	1	25	P*80	Pivot Pin Plated	1
8	0704	M12 C Washer	22	26	0714	M8 Mudguard Washer	2
9	P*81	Anvil	1	27	0344	M8/16 Bolt	2
10	1511	M16 P Nyloc Nut	1	28	P*147	M10/100 Bolt	2
11	1143	M16 A Washer	1	29	P*194	Roller Dead Plate	1
12	18285	M16 Nordlock Washer	2	30	0701	M10 A Washer	4
13	P*211	M16/70 Caphead	1	31	18037	M8/12 Bolt	4
14	18181	M16/35 Caphead	1	32	1348	Limit Switch	1
15	P*60	Nylon Side Plate	2	33	0178	Buffer Rubber Pad	1
16	P*62	Roller Box Base Plate	1	34	P*184	Switch Mounting Bracket Plated	1
17	4342	M8/30 CSK Screw	2	35	1868	Av Mount 30 X 40 60 Shore	2
18	18172	M12/45 Bolt	4	36	1006	M4/30 Pan Pozi	2



## SX200 - PETROL MODELS

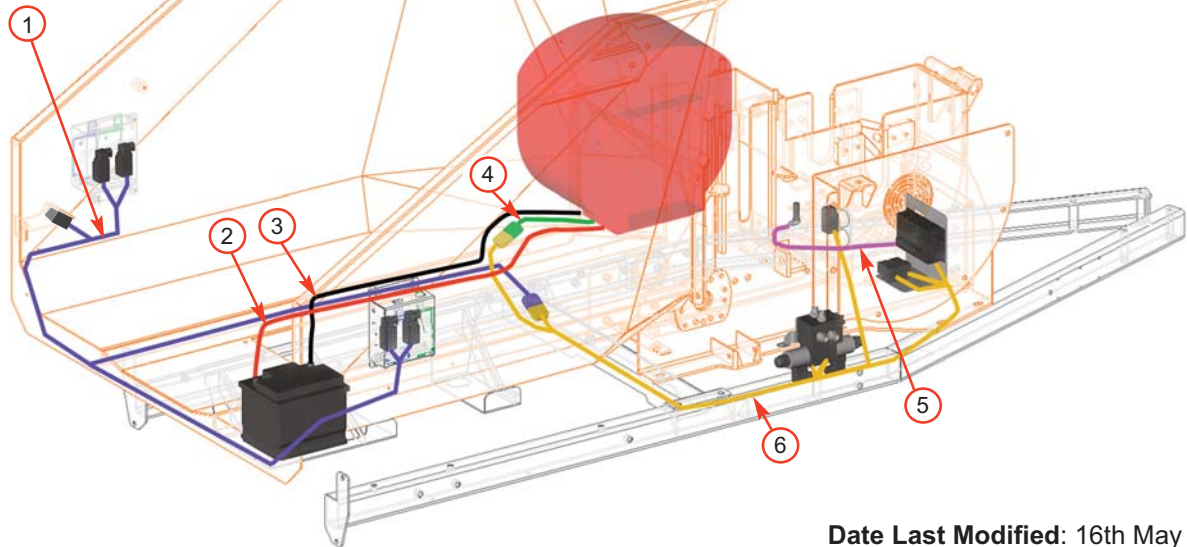

Date Last Modified: 16th May 2013

Item	Part No	Part Name	Q'ty	Item	Part No	Part Name	Q'ty
1	P*53	Funnel Loom	1	4	P*54	Engine Loom	1
2	P*106	Positive Battery Lead	1	5	1638	Sensor Wabco	1
3	P*107	Negative Battery Lead	1	6	P*52	Main Shredder Loom	1

## SX200 - DIESEL MODELS

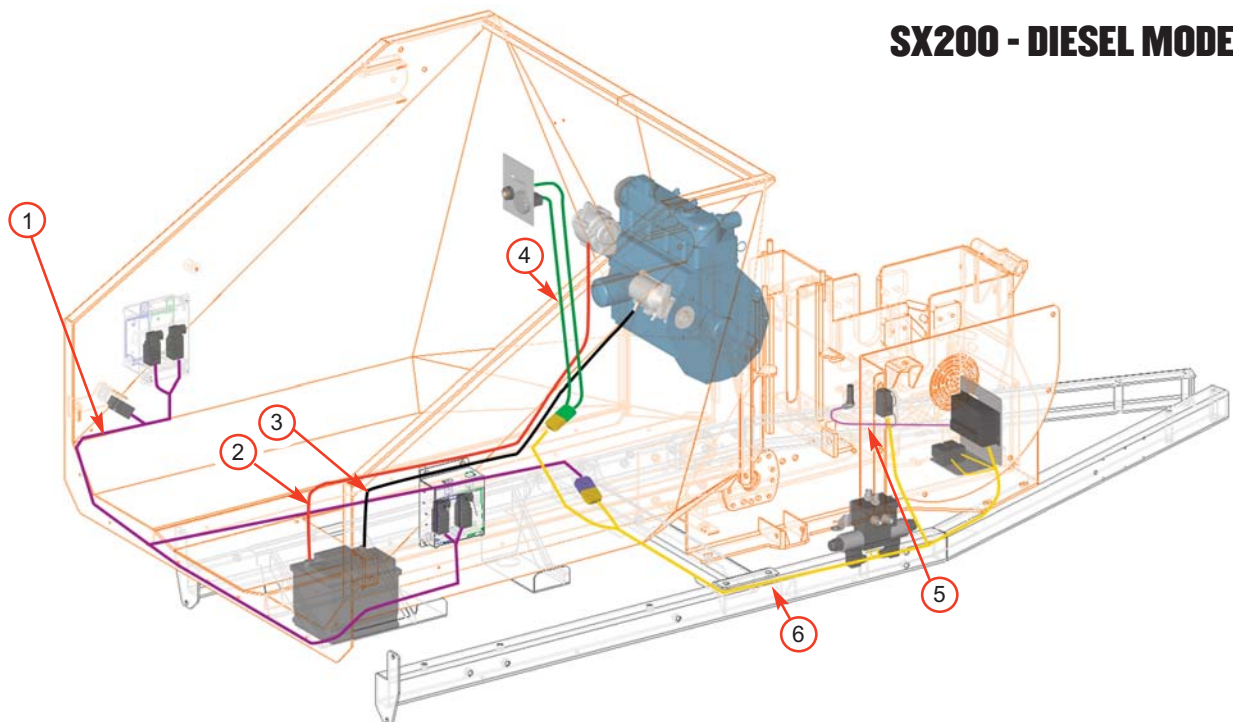

Date Last Modified: 30th May 2013

Item	Part No	Part Name	Q'ty	Item	Part No	Part Name	Q'ty
1	P*53	Funnel Loom	1	4	P*373	Engine Loom	1
2	P*374	Positive Battery Lead	1	5	1638	Sensor Wabco	1
3	P*375	Negative Battery Lead	1	6	P*319	Main Shredder Loom	1

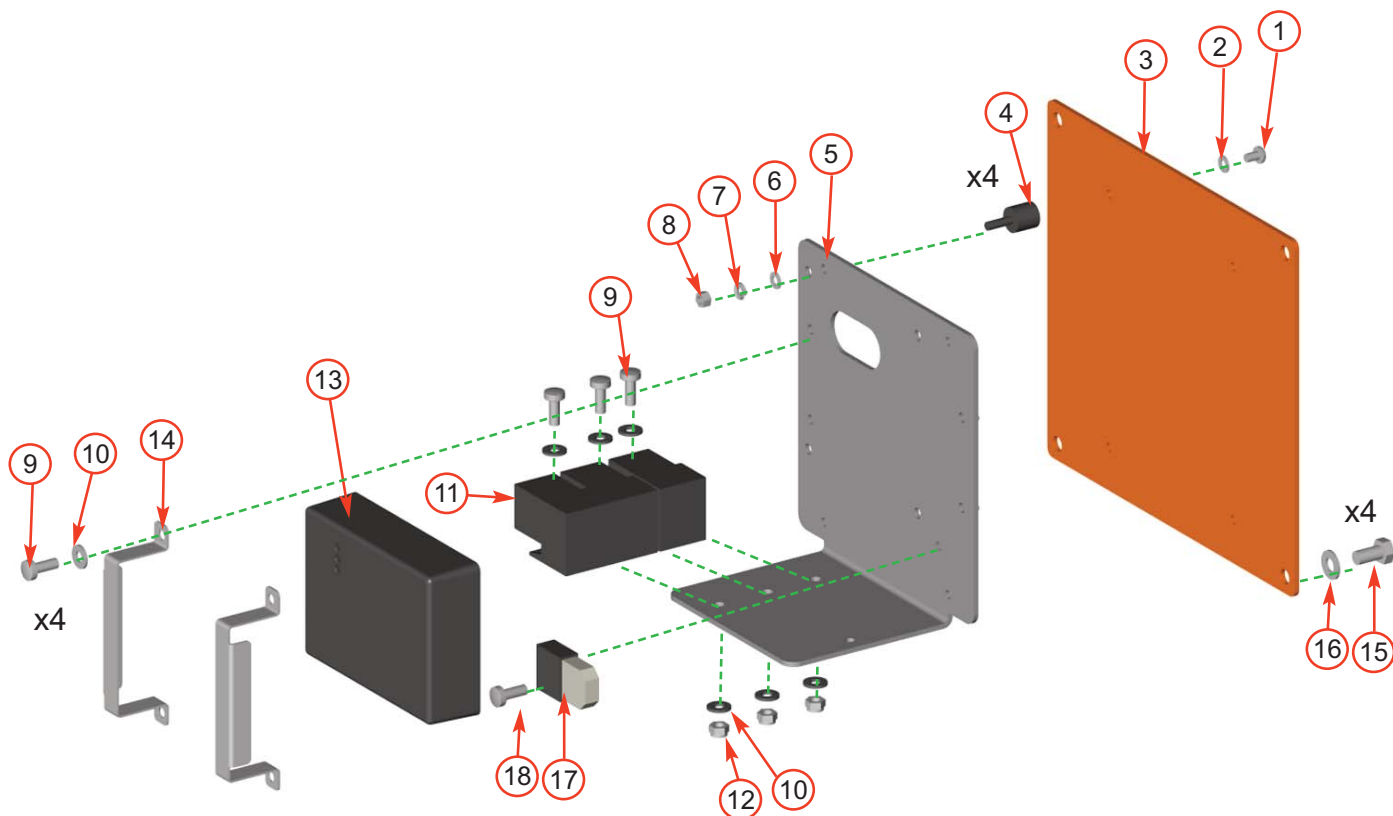

Date Last Modified: 14th May 2013

Item	Part No	Part Name	Q'ty	Item	Part No	Part Name	Q'ty
1	18103	M5/8 Pan Pozi	4	10	0709	M6 C Washer	10
2	0708	M5 C Washer	4	11	Supp'd with loom	Relay	2
3	P*51	Mounting Plate	1	12	0391	M6 T Nyloc Nut	2
4	17999	AV Mount	4	13	18405	H-Box	1
5	P*50	Electrical Panel	1	14	18398	Mounting Bracket	2
6	0857	M5 A Washer	4	15	0344	M8/16 Bolt	4
7	3024	M5 Spring Washer	4	16	0711	M8 A Washer	4
8	18291	M5 Plain Nut	4	17	Supp'd with loom	Fuse	1
9	0438	M6/16 Pan Pozi	5	18	1151	Countersunk Pop Rivet	1





Date Last Modified: 4th June 2013

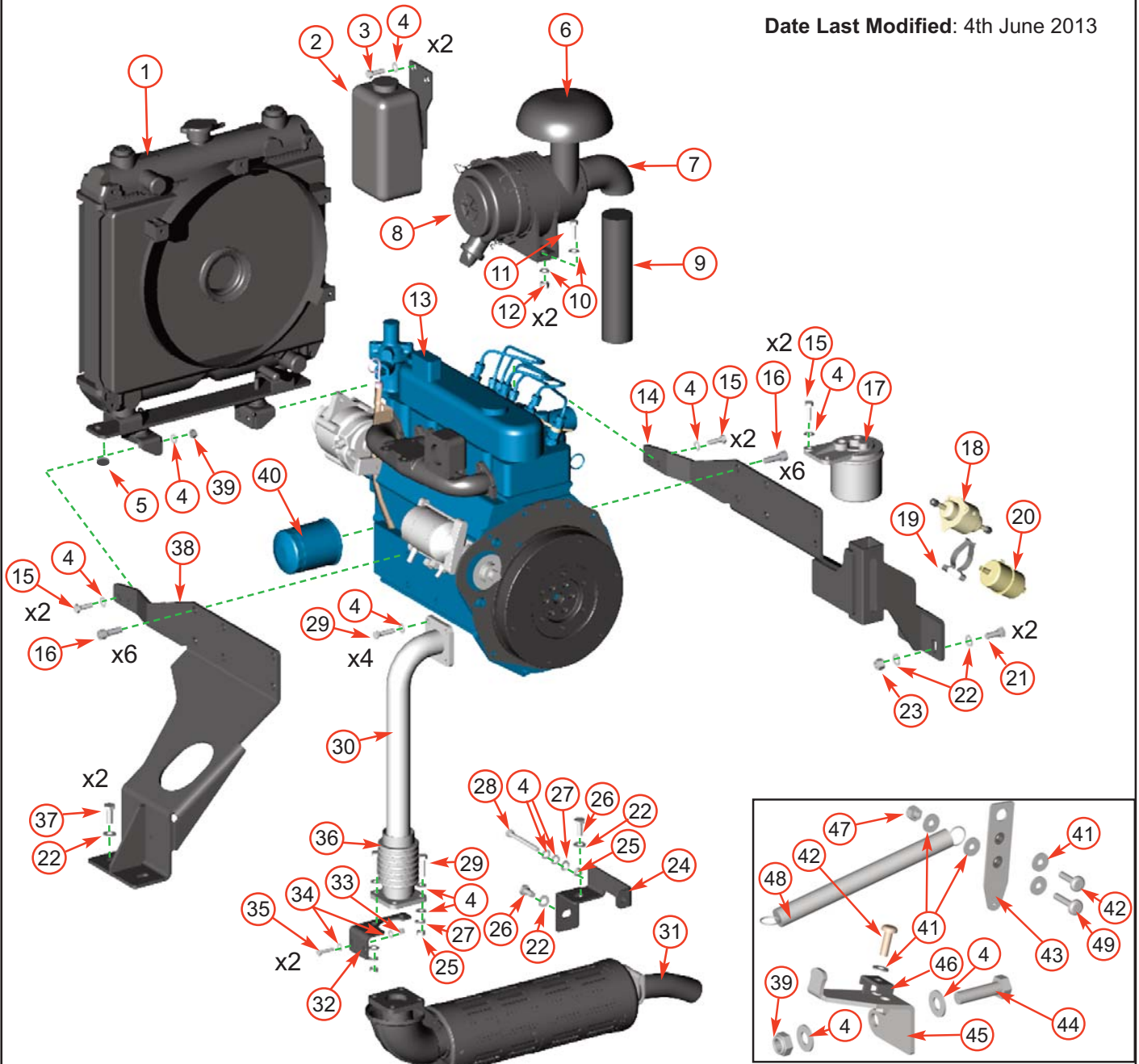

Item Part No	Part Name	Q'ty	Item Part No	Part Name	Q'ty	Item Part No	Part Name	Q'ty
1	P*430 Radiator Kit	1	18	0807 Fuel Pump	1	35	1253 M6/25 Bolt	2
2	4320 Reserve Tank	1	19	2851 Clip Fuel Filter	1	36	P*318 Flexible Muffler Adapter	1
3	0344 M8/16 Bolt	2	20	4315 In-line Fuel Filter	1	37	1812 M10/35 Bolt	2
4	6711 M8 A Washer	34	21	0382 M10/30 Bolt	2	38	P*311 Rear Engine Bracket	1
5	P*436 Radiator Boss	2	22	0839 M10 C Washer	10	39	0481 M8 T Nyloc Nut	6
6	P*433 Air Filter Cap	1	23	4345 M10 P Nyloc Nut	2	40	0095 Oil Filter	1
7	P*432 Air Filter Kit	1	24	P*315 Muffler Mounting Front Brkt	1	41	0708 M5 C Washers	5
8	P*431 Air Filter	1	25	0476 M8 Plain Nut	5	42	0435 M5/16 Pan Pozi	2
9	P*435 Air Intake Pipe	1	26	0878 M10/20 Bolt	2	43	1090F Throttle Arm Ext.	1
10	0712 M8 C Washer	4	27	1008 M8 Spring Washer	5	44	0352 M8/40 Bolt	2
11	0351 M8/30 Bolt	2	28	18118 M8/70 Bolt	1	45	2814FS Throttle Cable Clamp	1
12	0479 M8 P Nyloc Nut	2	29	18117 M8/35 Bolt	8	46	0699 Throttle Clamp	1
13	P*283 Engine	1	30	P*309 Exhaust Pipe	1	47	0236 M5 P Nyloc Nut	1
14	P*312 Rear Engine Bracket	1	31	P*434 Muffler	1	48	1304 Spring	1
15	0350 M8/25 Bolt	6	32	P*314 Muffler Mounting Rear Brkt	1	49	0856 M5/20 Pan Pozi	1
16	18124 M10/20 Caphead	12	33	0142 M6 P Nyloc Nut	2			
17	0085 Fuel Filter	1	34	0709 M6 C Washer	4			

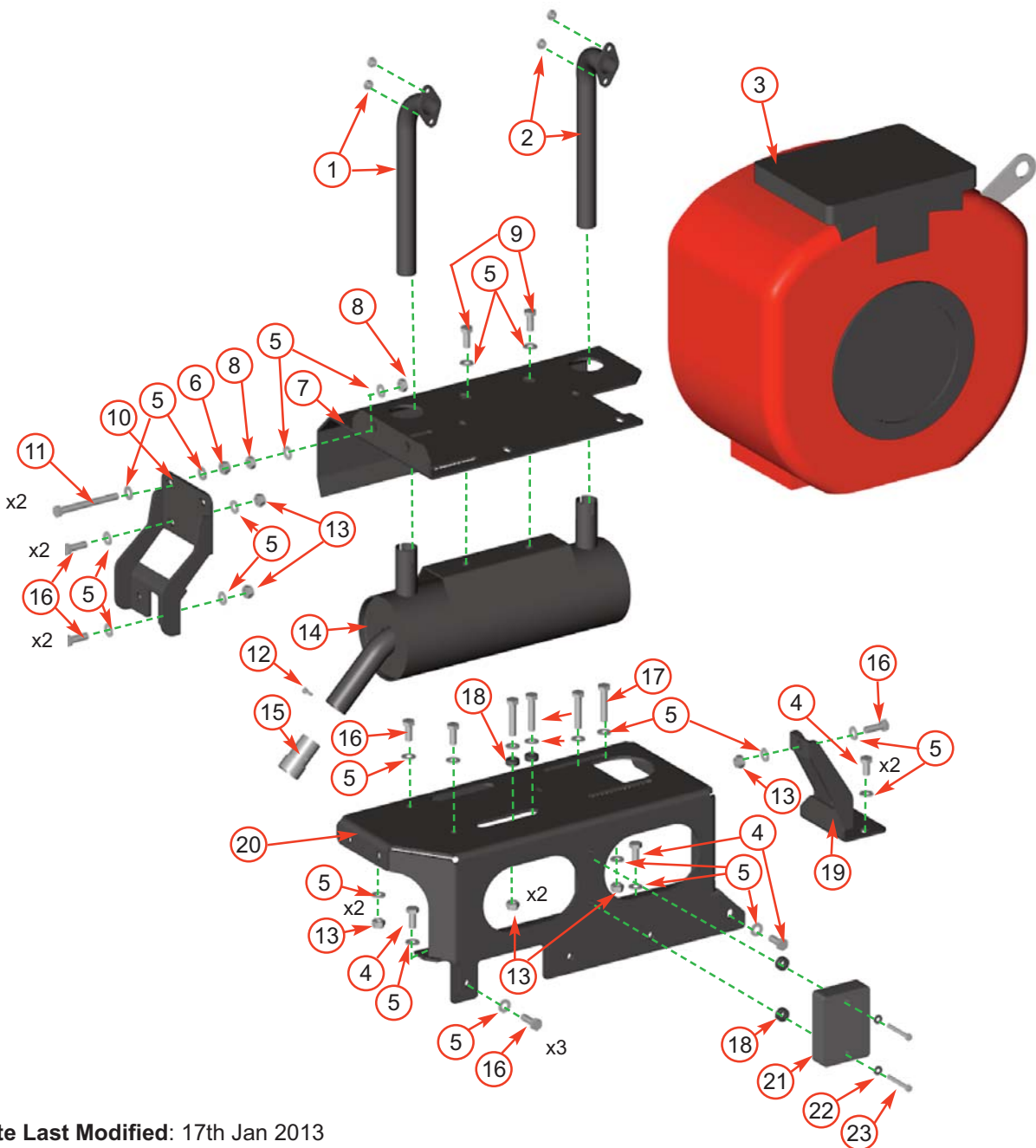

Date Last Modified: 17th Jan 2013

Item	Part No	Part Name	Q'ty	Item	Part No	Part Name	Q'ty
1	19364F	Exhaust Port Pipe, Oil Filter Side	1	13	4345	M10 P Nyloc Nut	8
2	19365F	Exhaust Port Pipe, Starter Motor Side	1	14	19374F	Muffler	1
3	19296	Engine Gx630	1	15	19370	Honda Spark Arrester	1
4	0360	M10/25 Bolt	7	16	0382	M10/30 Bolt	8
5	0839	M10 C Washer	38	17	P*209	M10/55 Bolt	4
6	0052	M10 T Nyloc Nut	4	18	19535M	Spacer Boss	4
7	P*111	Engine Adjuster Plate	1	19	P*137	Engine Bracket Strut	1
8	1036	M10 Plain Nut	4	20	P*105	Engine Support Bracket	1
9	0318	M12/20 Bolt	2	21	Supp'd with engine	Rectifier Unit	1
10	P*112	Engine Adjuster Bracket	1	22	0709	M6 C Washer	2
11	P*147	M10/100 Bolt	2	23	P*210	M6/35 Bolt	2
12	1353	M5/16 Pop Rivet	1				

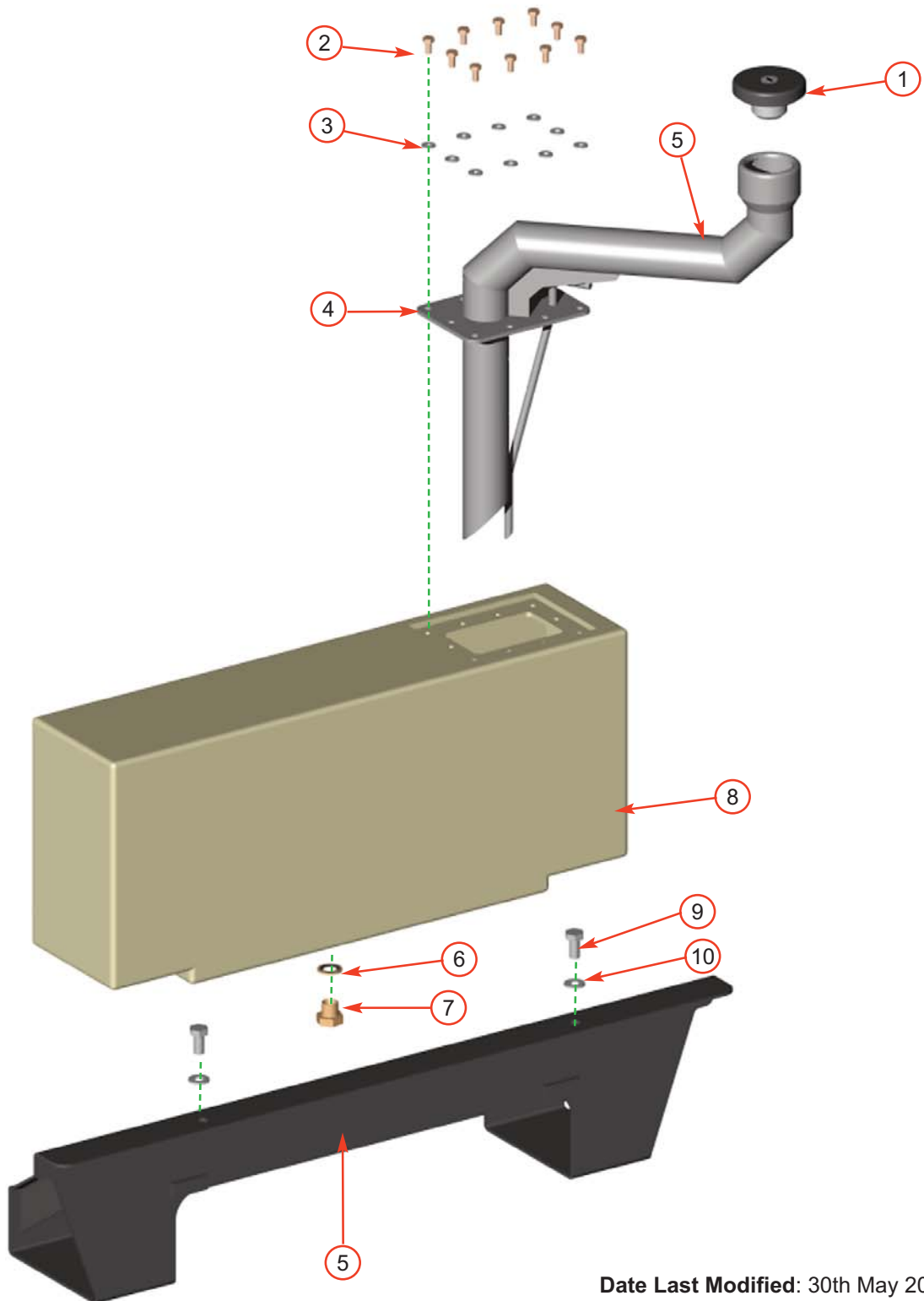

Date Last Modified: 30th May 2013

Item	Part No	Part Name	Q'ty	Item	Part No	Part Name	Q'ty
1	1374	Locking Tank Cap	1	7	0211	3/8" Drain Plug	1
2	1658	M6/12 Bolt	10	8	1872	Petrol Tank	1
3	0709	M6 C Washer	10		1566	Diesel Tank	1
4	P*104	Fuel Filler Assembly	1	9	0878	M10/20 Bolt	2
5	P*65	Fuel Tank Bracket	1	10	0839	M10 C Washer	2
6	0396	3/8" Dowty Washer	1				

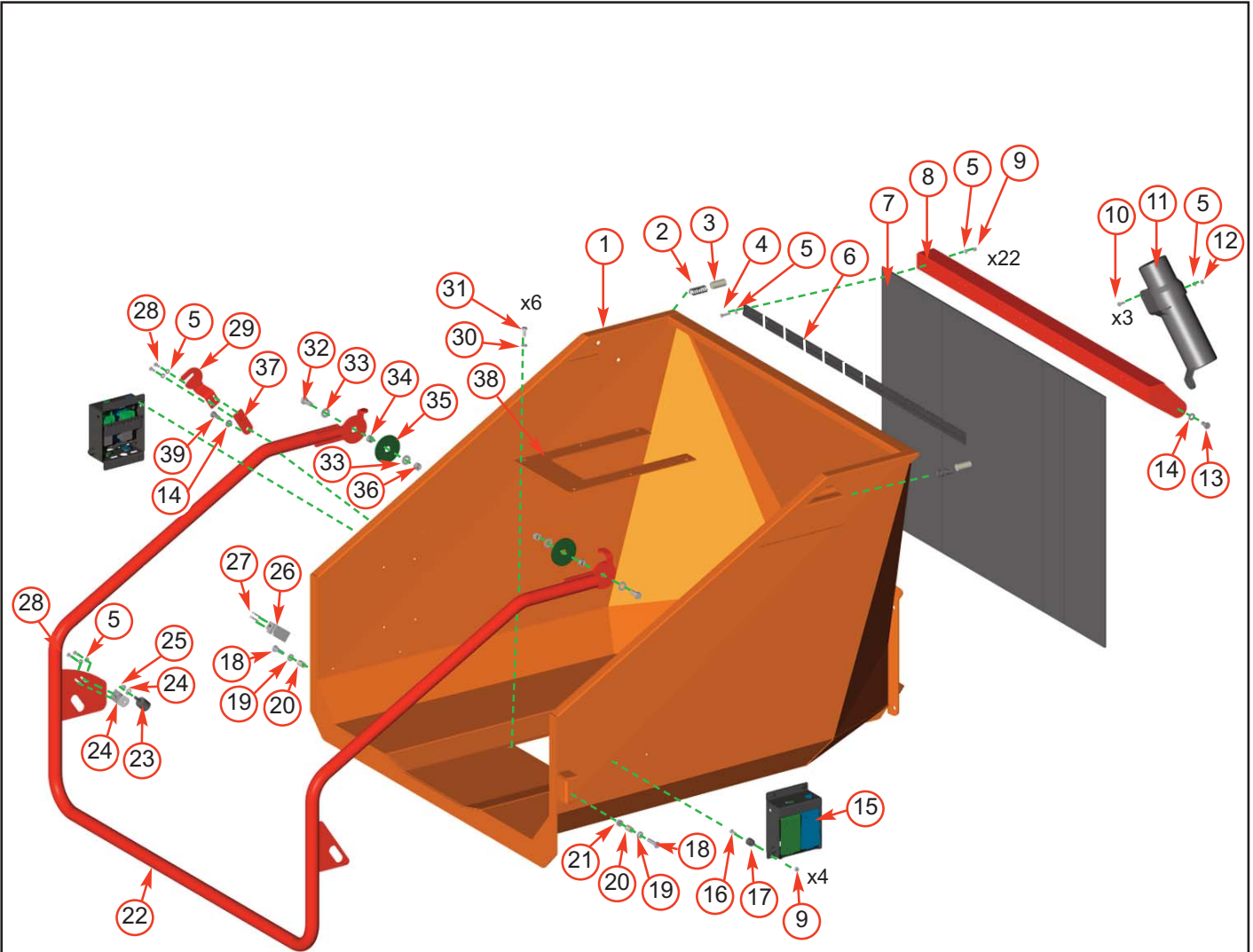

Date Last Modified: 22nd March 2013

Item	Part No	Part Name	Q'ty	Item	Part No	Part Name	Q'ty
1	P*132	Funnel	1	21	4345	M10 P Nyloc Nut	2
2	P*177	Control Bar Spring	1	22	P*34	Control Stop Bar	1
3	1601	Nylon Piston	2	23	0178	Rubber End Stop	1
4	1253	M6/25 Bolt	22	24	2727FS	Actuator Bracket	1
5	0709	M6 C Washer	51	24	0712	M8 C Washer	1
6	19650F	Safety Curtain Clamp	11	25	0479	M8 P Nyloc Nut	1
7	P*69	Safety Curtain Strip Long	11	26	1348	Limit Switch	1
8	P*56	Curtain Rail	1	27	1006	M4/30 Pan Pozi	2
9	0142	M6 P Nyloc Nut	30	28	0437	M6/16 Bolt	4
10	0438	M6/16 Pan Pozi	3	29	P*202	Adjustable Control Bar Catch	1
11	P*144	Operator's Manual Canister	1	30	0346	M8/20 Bolt	6
12	0391	M6 T Nyloc Nut	3	31	0711	M8 A Washer	6
13	18127	M10/16 Bolt	4	32	0429	M12/35 Bolt	2
14	0839	M10 C Washer	5	33	0704	M12 C Washer	4
15	(see page 40)	Control Box	2	34	1605M	Stainless Spacer	2
16	18108	M6/8 Pan Pozi	8	35	1599	Bearing Washer	2
17	18000	AV Mount	8	36	0045	M12 T Nyloc Nut	2
18	1520	M10/45 Bolt	2	37	P*203	Control Bar Catch Adjuster	1
19	4344	M10 Repair Washer	2	38	P*185	Inspection Plate	1
20	1591	Nylon Spacer	2	39	0360	M10/25 Bolt	1

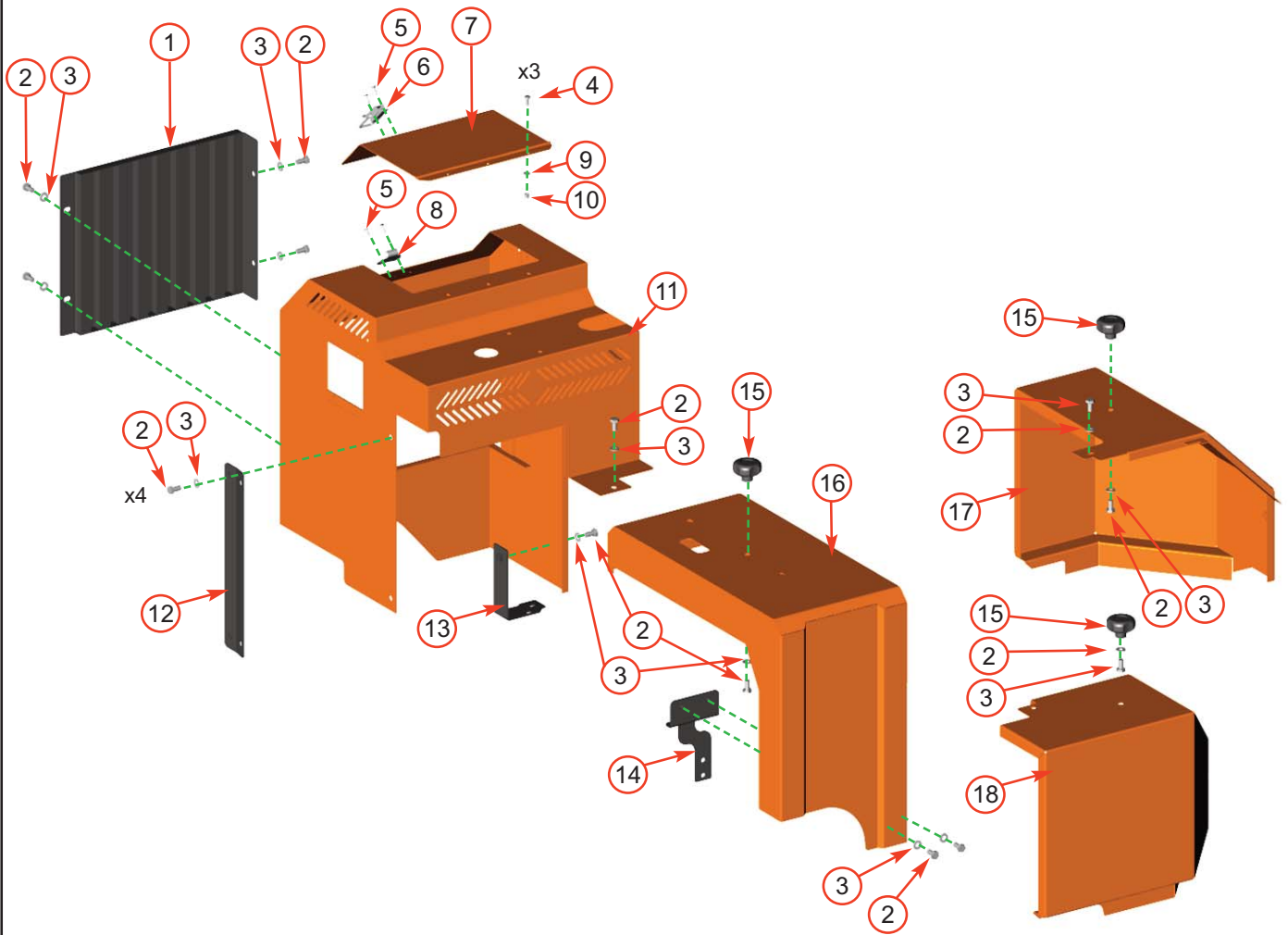

Date Last Modified: 5th June 2013

Item	Part No	Part Name	Q'ty	Item	Part No	Part Name	Q'ty
1	P*438	Air Grill	1	10	0391	M6 T Nyloc Nut	3
2	0878	M10/20 Bolt	16	11	P*437	Engine Guard	1
3	0839	M10 C Washer	16	12	P*439	Engine Guard Mount	1
4	0438	M6/16 Pan Pozi	3	13	P*428	Engine Guard Bracket	1
5	0067	Pop Rivet 4.8 x 12	4	14	P*429	Motor/Pump Guard Bracket	1
6	0235	Catch	1	15	0361	Knob	3
7	17544	Access Panel	1	16	P*440	Motor Guard	1
8	4088	Catch Plate	1	17	P*442	Belt Guard	1
9	0709	M6 C Washer	3	18	P*441	Pump Guard	1



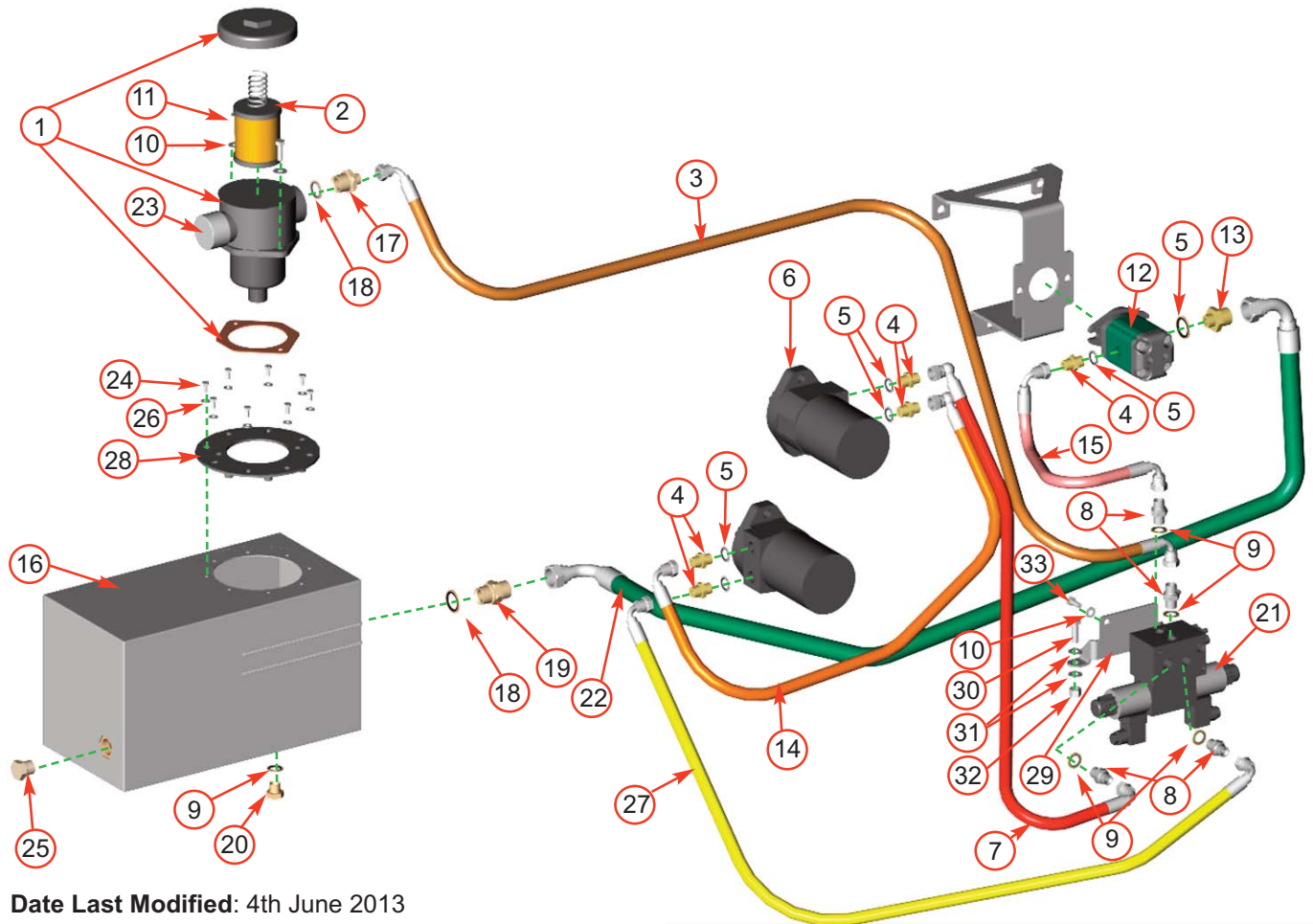

Date Last Modified: 4th June 2013

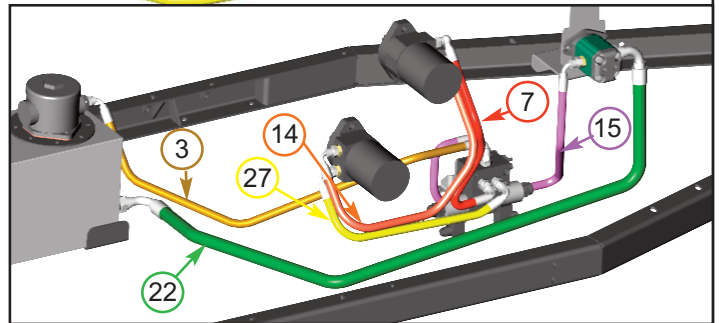
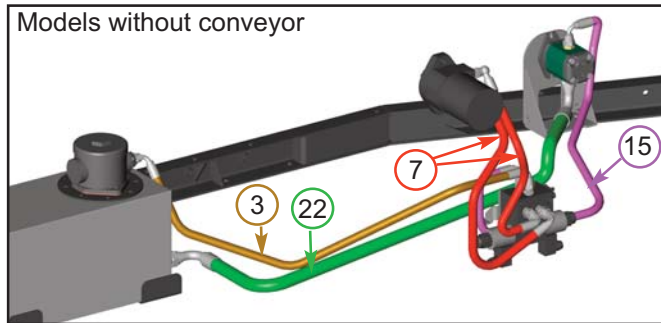

Item	Part No	Part Name	Q'ty
1	1434	Tank Top Filter Housing	1
2	0100	Filter	1
3	P*118	Hose 3/8" 1350mm	1
4	0026	Adaptor mm 1/2" - 3/8" BSP	5
5	0398	Washer Dowty 1/2"	6
6	2982B	Hydraulic Motor	2
		Non-conveyor option	1
7	P*113	Hose 3/8" 610mm	1
		Non-conveyor option	2
8	0161	Adaptor mm 3/8" - 3/8" BSP	4
9	0396	Washer Dowty 3/8"	5
10	0711	M8 A Washer	4
11	0350	M8/25 Bolt	2
12	P*59	Hydraulic Pump	1
13	1583	Adaptor 1/2" - 3/4" BSP	1
14	P*115	Hose 3/8" 700mm (conveyor option only)	1
15	P*382	Hose 3/8" 340mm	1
16	1703	Hydraulic Oil Tank	1

Item	Part No	Part Name	Q'ty
17	0225	Adaptor 3/4" - 3/8"	1
18	0152	Washer Dowty 3/4"	2
19	1766	Adapter 3/4" - 3/4" BSP	1
20	0211	3/8" BSP Plug	1
21	19369	Directional Control Valve (DCV)110 BAR	1
22	P*328	Hose 3/4" 1450mm	1
23	1067	Breather Filter	1
24	1658	M6/12 Bolt	8
25	4219	3/4" Tapered Blanking Plug	1
26	0709	M6 C Washer	8
27	P*116	Hose 3/8" 580mm (conveyor option only)	1
28	1702F	Tank Top Plate	1
29	P*77	C-Top Mounting Bracket	1
30	0382	M10/30 Bolt	2
31	0701	M10 A Washer	4
32	4345	M10 P Nyloc Nut	2
33	0346	M8/20 Bolt	2

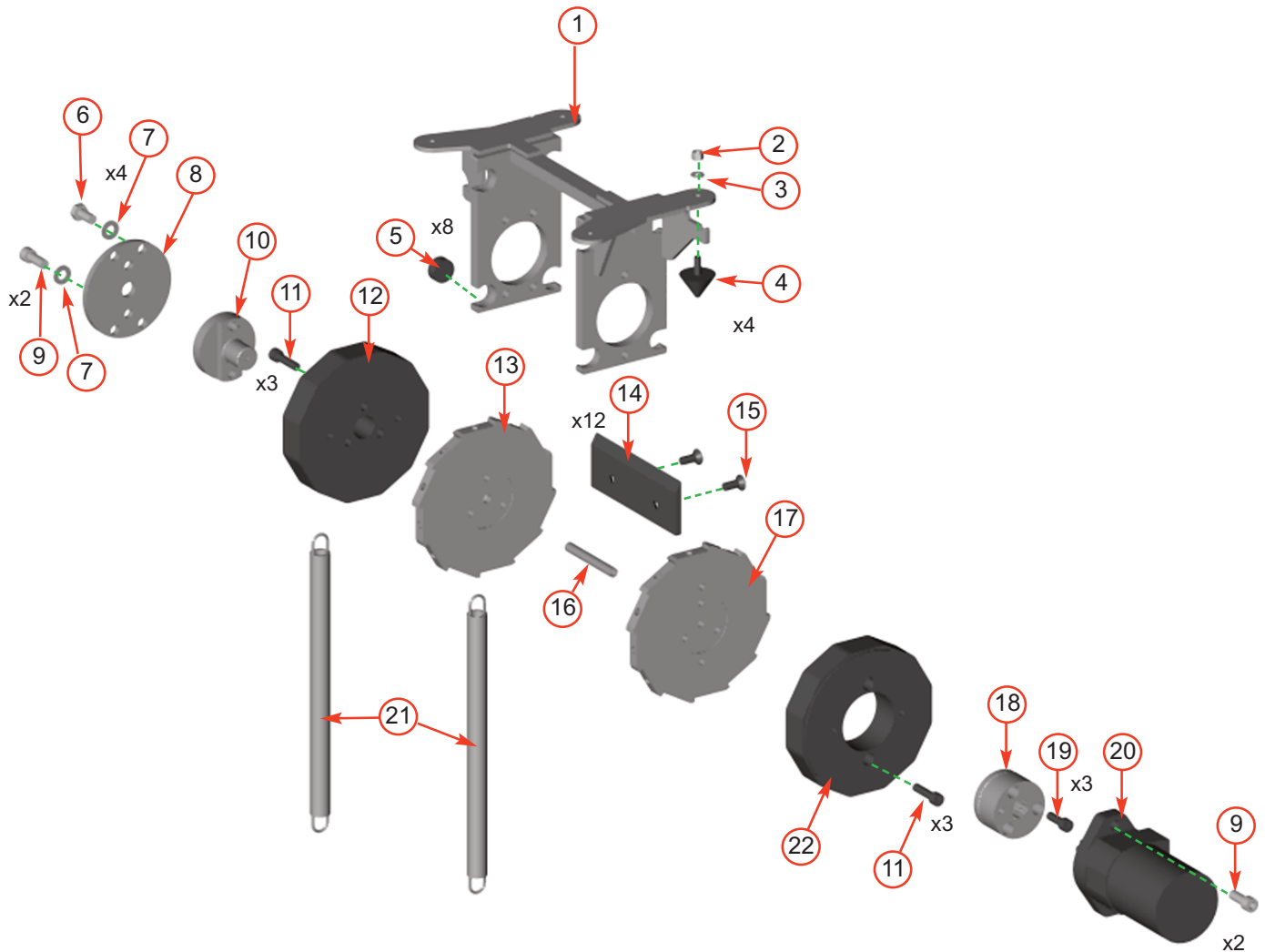

Date Last Modified: 28th May 2013

Item	Part No	Part Name	Q'ty	Item	Part No	Part Name	Q'ty
1	P*290	Top Slider Assy	1	12	P*288	Support Bearing	1
2	0479	M8 P Nyloc Nut	4	13	P*298	Roller Flange	1
3	0711	M8 A Washer	4	14	P*287	Blade	12
4	18475	Buffer Cone	4	15	P*296	M10/25 Csk Skt	24
5	3009	Slide Plug	8	16	P*44	Roller Grease Tube	1
6	0277	M12/25 Bolt	4	17	P*297	Roller Drive Flange	1
7	0702	M12 A Washer	6	18	P*38	Roller Spline Drive	1
8	17374PS	Back Plate Profile	1	19	0386	M10/30 Caphead	3
9	1985	M12/30 Caphead	4	20	2982B	Motor	1
10	17375M	Stub Shaft	1	21	18070	Roller Box Spring	2
11	1525	M10/40 Caphead	6	22	P*289	Filler Disc	



## TIMBERWOLF V-BELT TENSIONING DATA TABLE

### METHOD:

1. SET THE DEFLECTION DISTANCE ON THE LOWER SCALE OF THE TENSION GAUGE SO THAT THE UNDERSIDE OF THE 'O'-RING EQUALS THE 'h' VALUE GIVEN IN THE TABLE BELOW
2. ENSURE THAT THE DEFLECTION FORCE SCALE IS ZERO'D BY PUSHING THE UPPER 'O'-RING ALL THE WAY DOWN
3. PLACE THE TENSION GAUGE IN THE CENTRE OF THE BELT SPAN AS SHOWN IN THE DIAGRAM LEFT
4. PRESS DOWNWARDS ON THE RUBBER BUFFER, DEFLECTING THE BELT UNTIL THE UNDERSIDE OF THE LOWER O-RING IS LEVEL WITH THE BELT BEHIND (USE A STRAIGHT EDGE IF THERE IS ONLY 1 BELT)
5. TAKE THE READING FROM THE DEFLECTION SCALE OF THE TENSION METER (READ AT THE LOWER EDGE OF THE 'O'-RING) & COMPARE THIS VALUE WITH THAT GIVEN IN THE TABLE BELOW
6. TIGHTEN OR LOOSEN BELTS AS REQUIRED FOLLOWING PROCEDURE GIVEN IN THE OPERATOR'S MANUAL

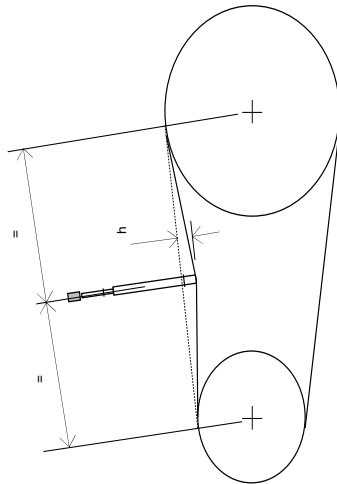

### TIPS ON BELT TIGHTENING:

- A) THERE WILL NORMALLY BE A RAPID DROP IN TENSION DURING THE RUN-IN PERIOD FOR NEW BELTS. WHEN NEW BELTS ARE FITTED, CHECK THE TENSION EVERY 2-3 HOURS & ADJUST UNTIL THE TENSION REMAINS CONSTANT
- B) THE BEST TENSION FOR V-BELT DRIVES IS THE LOWEST TENSION AT WHICH THE BELTS DO NOT SLIP OR RATCHET UNDER THE HIGHEST LOAD CONDITION
- C) TOO MUCH TENSION SHORTENS BELT & BEARING LIFE
- D) TOO LITTLE TENSION WILL AFFECT THE PERFORMANCE OF YOUR MACHINE ESPECIALLY IN RESPECT OF NO-STRESS DEVICES
- E) ENSURE THAT BELT DRIVES ARE KEPT FREE OF ANY FOREIGN MATERIALS
- F) IF A BELT SLIPS - TIGHTEN IT!

TENSION GAUGES ARE AVAILABLE FROM TIMBERWOLF SPARES, QUOTING PART No. 18091

TW MODEL No.:		1375G	18/100G	125PH	150DHB	150VTR	190TDHB	190TFTR	190TVGTR	350DHB(t)	PTO100	PTO150	S426 SHREDDER	S426TFTR SHREDDER	PTO S426 SHREDDER	SX200 - ALL MODELS
Belt Mfr / Type		Gates Super HC-MN	Gates Super HC-MN	Gates Super HC-MN	Gates Super HC-MN	Gates Super HC-MN	Gates Super HC-MN	Gates Super HC-MN	Gates Super HC-MN	Gates Super HC-MN	Gates Super HC-MN	Gates Super HC-MN	Gates Super HC-MN	Gates Super HC-MN	Gates Super HC-MN	M
Belt Pitch Designation		SPA	SPA	SPA	SPA	SPA	SPA	SPA	SPA	SPA	SPA	SPA	SPA	SPA	SPA	SPA
Belt Length		900.0	1060.0	1060.0	1060.0	1060.0	1232.0	1232.0	1232.0	2530.0	900.0	900.0	2120.0	2120.0	1700.0	1272.0
<b>Belt deflection</b>	= h	<b>4.0</b>	<b>4.0</b>	<b>3.5</b>	<b>4.0</b>	<b>4.0</b>	<b>4.0</b>	<b>4.0</b>	<b>4.0</b>	<b>8.0</b>	<b>4.0</b>	<b>4.0</b>	<b>8.0</b>	<b>8.0</b>	<b>6.0</b>	<b>5.0</b>
<b>Force reading (Kgf)</b>	New belt	<b>3.4 - 3.6</b>	<b>3.1 - 3.3</b>	<b>3.3 - 3.6</b>	<b>4.3 - 4.5</b>	<b>4.3 - 4.5</b>	<b>3.9 - 4.1</b>	<b>3.9 - 4.1</b>	<b>3.9 - 4.1</b>	<b>3.3 - 3.6</b>	<b>3.3 - 3.5</b>	<b>3.8 - 4.0</b>	<b>3.3 - 3.5*</b>	<b>3.3 - 3.5</b>	<b>6.5 - 6.9</b>	<b>1.9 - 2.1</b>
	Used belt	3.0 - 3.2	2.8 - 3.0	2.8 - 3.1	3.7 - 4.0	3.7 - 4.0	3.4 - 3.6	3.4 - 3.6	3.4 - 3.6	2.9 - 3.1	2.9 - 3.0	3.3 - 3.5	2.9 - 3.1*	2.9 - 3.1	5.6 - 6.0	1.7 - 1.8
Belt Mfr / Type		N/A	N/A	Gates Super HC-MN	N/A	Gates Super HC-MN	N/A	Gates Super HC-MN	Gates Super HC-MN	N/A	N/A	Gates Super HC-MN	N/A	Gates Super HC-MN	N/A	N/A
Belt Pitch Designation				SPA		SPA		SPA	SPA			SPA		SPA		
Belt Length				950.0		900.0		925.0	950.0			925.0		1060.0		
<b>Belt deflection</b>	= h			<b>4.0</b>		<b>4.0</b>		<b>4.0</b>	<b>4.0</b>			<b>4.0</b>		<b>4.0</b>		
<b>Force reading (Kgf)</b>	New belt			<b>1.9 - 2.0</b>		<b>2.3 - 2.4</b>		<b>2.3 - 2.4</b>	<b>2.3 - 2.4</b>			<b>2.0 - 2.2</b>		<b>2.7 - 2.9</b>		
	Used belt			1.7 - 1.8		2.0 - 2.1		2.0 - 2.2	2.0 - 2.2			1.8 - 2.0		2.3 - 2.5		