



<i>Section</i>	<i>Page No.</i>
INTRODUCTION	1
PURPOSE OF MACHINE	2
MACHINE DIMENSIONS & SPECIFICATIONS	2
PARTS LOCATION DIAGRAMS	3
SAFE WORKING	5
Operator's Personal Protective Equipment Required	5
Basic Woodchipping Safety	5
General Safety Matters - Do's and Dont's	6
Noise Test	7
OPERATING INSTRUCTIONS	8
Safe Transportation	8
Hitching onto the Tow Ball	8
Unhitching the Chipper	8
Delivery	9
Operator's Personal Protective Equipment Required	9
Manual Controls	9
Auto Controls	10
Emergency Stopping	10
Engine Controls	10
Blade Wear	10
Hydraulic Oil Level Indicator	10
Fuel Level Indicator	10
Daily Checks Before Starting	10
Before Using the Chipper	11
Starting the Engine	11
Stopping the Engine	11
Discharge Controls	11
Starting to Chip	12
Chipping	12
Blockages	12
SERVICE INSTRUCTIONS	13
Service Schedule	14
Safe Maintenance	15
Safe Lifting of the Chipper	15
Spares	15
Battery Removal and Maintenance	15
Copper Ease Safety Information	16
Battery Safety Information	16
Change Blades	18
Tension Drive Belts	19
Change Hydraulic Oil and Filter	19
Grease the Discharge Flange	19
Grease the Roller Spline and Bearing	20
Grease the Roller Box Slides	20
Greasing Rotor Bearings	20
Engine Servicing	20
Check Hoses	20
WARRANTY STATEMENT	21
EC DECLARATION OF CONFORMITY CERTIFICATE	22
IDENTIFICATION PLATE	23
DECALS	24
ELECTRICAL DETAIL	26
CIRCUIT DIAGRAM	27
HYDRAULIC LAYOUT	28
PARTS LISTS	30



INTRODUCTION

Thank you for choosing this Timberwolf brushwood chipper. Timberwolf chippers are designed to give safe and dependable service if operated according to the instructions.

IMPORTANT HEALTH AND SAFETY INFORMATION

Before using your new chipper, please take time to read this manual which contains and explains the chipper controls. Failure to do so could result in:

- PERSONAL INJURY
- EQUIPMENT DAMAGE
- DAMAGE TO PROPERTY
- A MEMBER OF THE GENERAL PUBLIC BECOMING INJURED

This manual covers the operation and maintenance of the Timberwolf TW 150DHB. All information in this manual is based on the latest product information available at the time.

All the information you need to operate the machine safely and effectively is contained within pages 3 to 12. Ensure that all operators are **properly trained** for operating this machine, especially with regard to **safe working practices**.

Timberwolf's policy of constantly improving their products may involve major or minor changes to the chippers or their accessories. Timberwolf reserves the right to make changes at any time without notice and without incurring any obligation.

Due to improvements in design and performance during production there may be, in some cases, minor discrepancies between the actual chipper and the text in this manual.

The manual should be considered a permanent part of the machine and should remain with it if the machine is resold.

ALWAYS FOLLOW SAFE OPERATING AND MAINTENANCE PRACTICES



CAUTION or WARNING

BE AWARE OF THIS SYMBOL AND WHERE SHOWN, CAREFULLY FOLLOW THE INSTRUCTIONS.

This caution symbol indicates important safety messages in this manual. When you see this symbol, be alert to the possibility of injury to yourself or others, and carefully read the message that follows.



The Timberwolf TW 150DHB

Designed to chip solid wood material up to 150mm in diameter and capable of chipping up to 4 tonnes of brushwood per hour.

DIMENSIONS

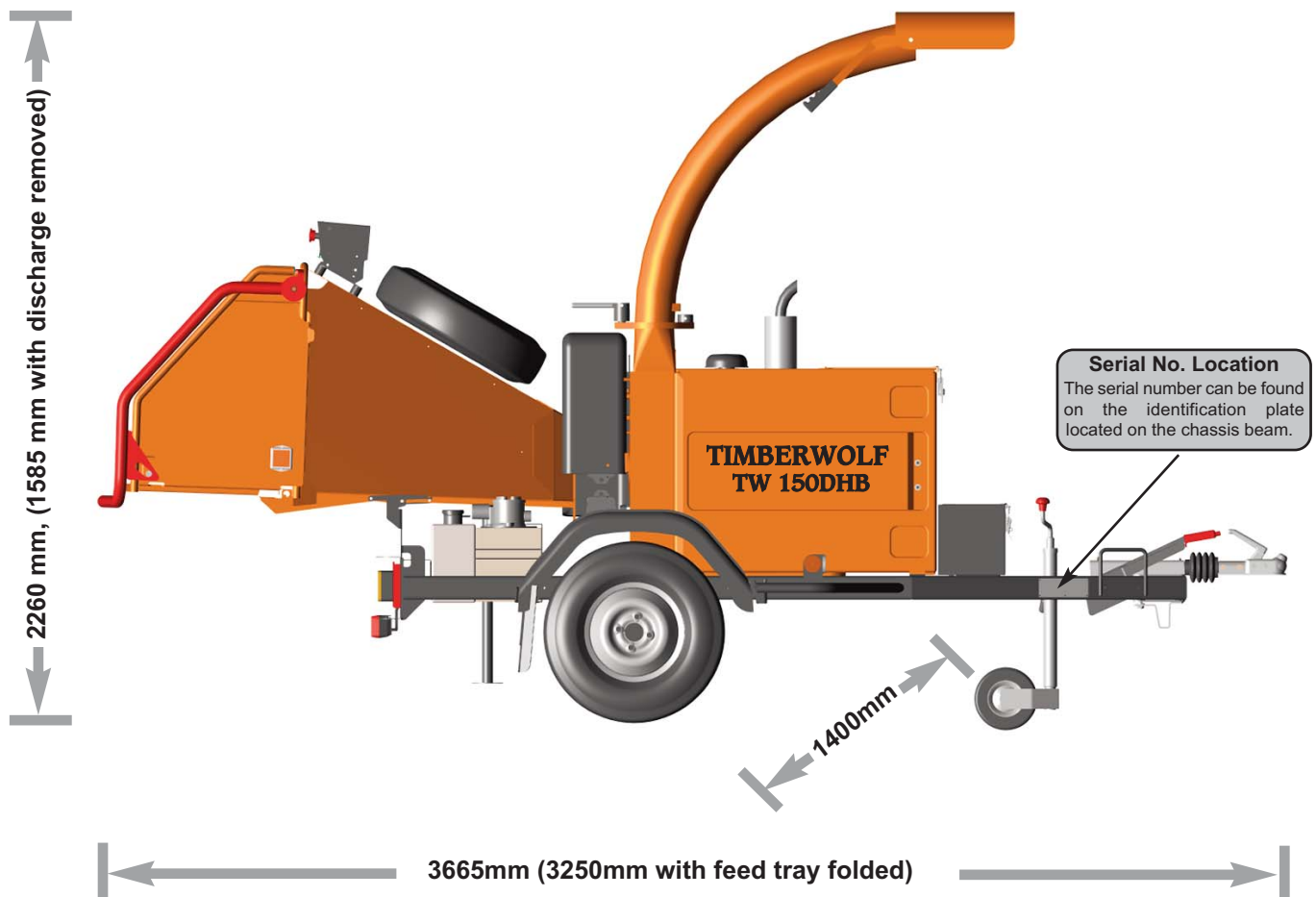

TIMBERWOLF TW 150DHB SPECIFICATION

Engine type:	<i>Kubota 4-cylinder diesel</i>	Maximum diameter material:	150mm (6")
Maximum power:	26kW (35hp)	Fuel capacity:	18 litres
Cooling method:	Water cooled	Hydraulic oil capacity:	15 litres
Overall weight:	737kg	Material processing capacity:	up to 4 tonnes/hr
Starting method:	Electric	Fuel type:	Diesel
Roller feed:	Twin hydraulic motors		



PARTS LOCATOR

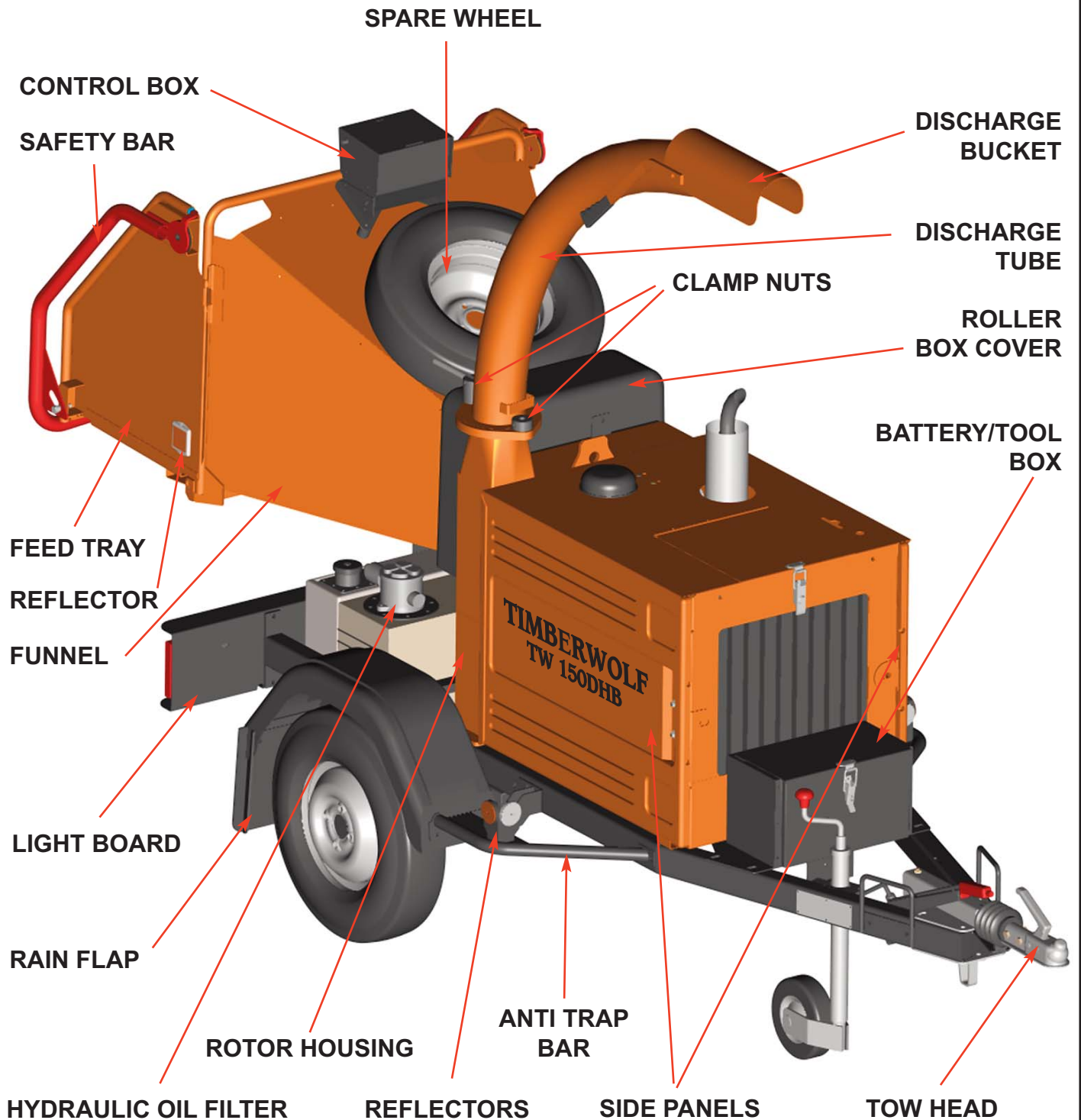



PARTS LOCATOR

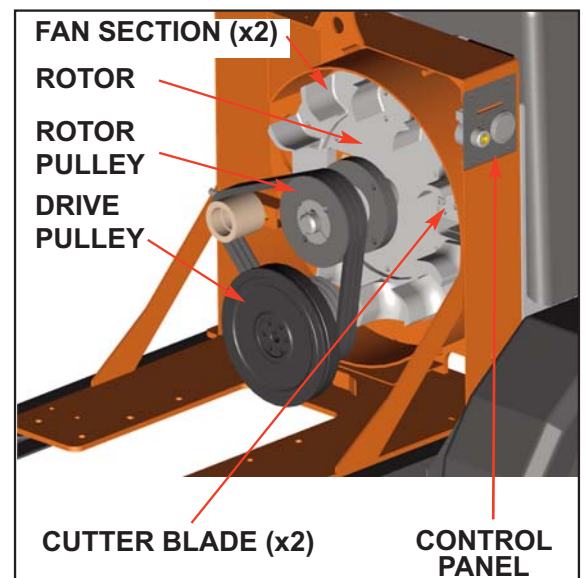
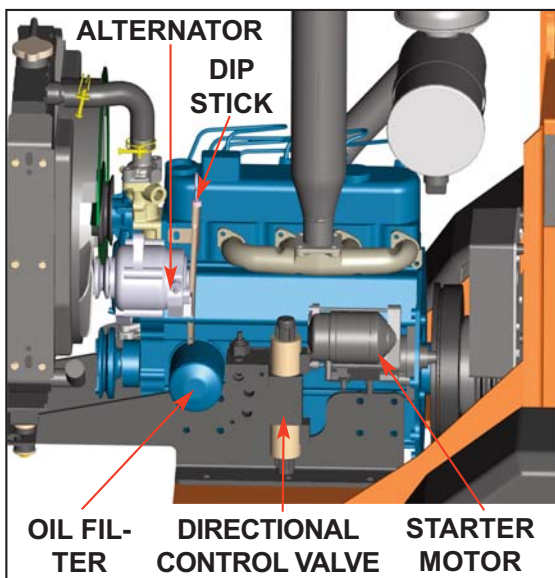
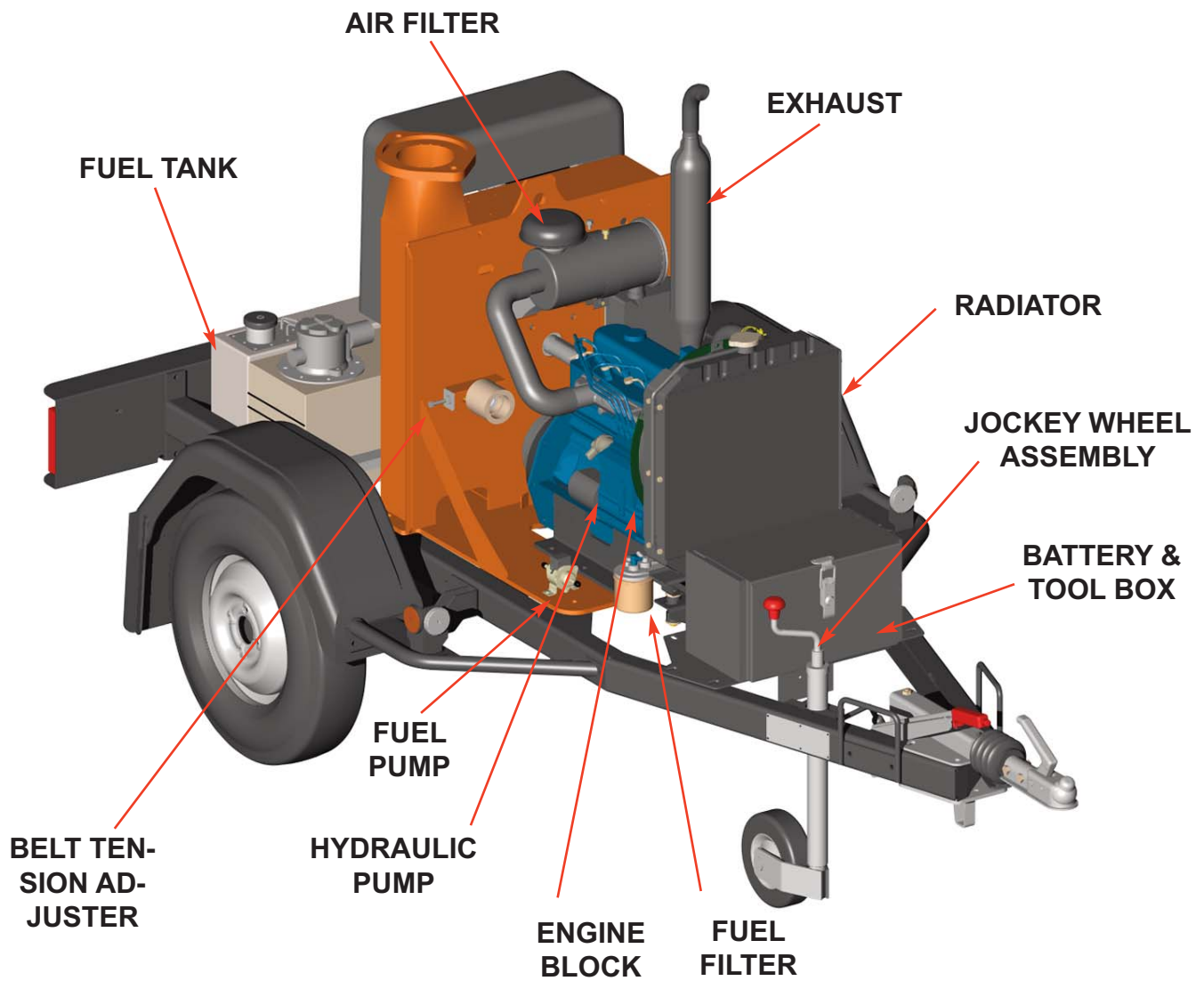



WARNING

The chipper will feed material through on its own. To do this, it relies on sharp blades both on the feed rollers and the chipper rotor. To keep the blades sharp, only feed the machine with clean brushwood. **DO NOT** put muddy/dirty wood, roots, potted plants, bricks, stones or metal into the chipper.



OPERATOR'S PERSONAL PROTECTIVE EQUIPMENT REQUIRED



Chainsaw safety helmet fitted with mesh visor and recommended ear defenders to the appropriate specifications.



Close fitting heavy-duty non-snag clothing.



Work gloves with elasticated wrist.



Face mask if appropriate.



Steel toe cap safety boots.



DO NOT wear rings, bracelets, watches, jewellery or any other items that could be caught in the material and draw you into the chipper.

BASIC WOODCHIPPING SAFETY

The operator should be aware of the following points:

- **MAINTAIN A SAFETY EXCLUSION ZONE** around the chipper of at least 10 metres for the general public or employees without adequate protection. Use hazard tape to identify this working area and keep it clear from debris build up. Chips should be ejected away from any area the general public have access to.
- **HAZARDOUS MATERIAL** - Some species of trees and bushes are poisonous. The chipping action can produce vapour, spray and dust that can irritate the skin. This may lead to respiratory problems or even cause serious poisoning. Check the material to be chipped before you start. Avoid confined spaces and use a facemask if necessary.
- **BE AWARE** when the chipper is processing material that is an awkward shape. The material can move from side to side in the funnel with great force. If the material extends beyond the funnel, the brush may push you to one side causing danger. Badly twisted brush should be trimmed before being chipped to avoid thrashing in the feed funnel.
- **BE AWARE** that the chipper can eject chips out of the feed funnel with considerable force. Always wear full head and face protection.
- **ALWAYS** work on the side of the machine furthest from any local danger, e.g. not road side.



GENERAL SAFETY MATTERS



DO'S AND DON'TS



ALWAYS stop the chipper engine before making any adjustments, refuelling or cleaning.

ALWAYS check rotor has stopped rotating and remove chipper ignition key before maintenance of any kind, or whenever the machine is to be left unattended.

ALWAYS check the machine is well supported and cannot move.

ALWAYS operate the chipper with the engine set to maximum speed when chipping.

ALWAYS check (visually) for fluid leaks.

ALWAYS take regular breaks. Wearing personal protective equipment for long periods can be tiring and hot.

ALWAYS keep hands, feet and clothing out of feed opening, discharge and moving parts.

ALWAYS use the next piece of material or a push stick to push in short pieces. Under no circumstances should you reach into the funnel.

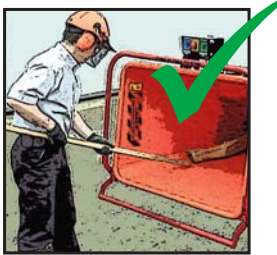

ALWAYS keep the operating area clear of people, animals and children.

ALWAYS keep the operating area clear from debris build up.

ALWAYS keep clear of the chip discharge tube. Foreign objects may be ejected with great force.

ALWAYS ensure protective guarding is in place before commencing work. Failure to do so may result in personal injury or loss of life.

ALWAYS operate the chipper in a well ventilated area - exhaust fumes are dangerous.

DO NOT operate chipper unless available light is sufficient to see clearly.

DO NOT use or attempt to start the chipper without the feed funnel, guards and discharge unit securely in place.

DO NOT stand directly in front of the feed funnel when using the chipper. Stand to one side.

DO NOT allow -



BRICKS STRING CLOTH PLASTIC STONES



METAL GLASS RUBBER ROOTS BEDDING PLANTS

- to enter the machine, as damage is likely.

DO NOT smoke when refuelling.



DO NOT let anyone who has not received instruction operate the machine.

DO NOT climb on the machine at any time.

DO NOT handle material that is partially engaged in the machine.

DO NOT touch any exposed wiring while machine is running.

DO NOT use the chipper inside buildings.



NOISE TEST

MACHINE: TW 150DHB

NOTES: Tested chipping 120mm x 120mm corsican pine 1.5m in length

Noise levels above 80dB (A) will be experienced at the working position. Wear ear protection at all times to prevent possible damage to hearing. All persons within a 4 metre radius must also wear good quality ear protection.

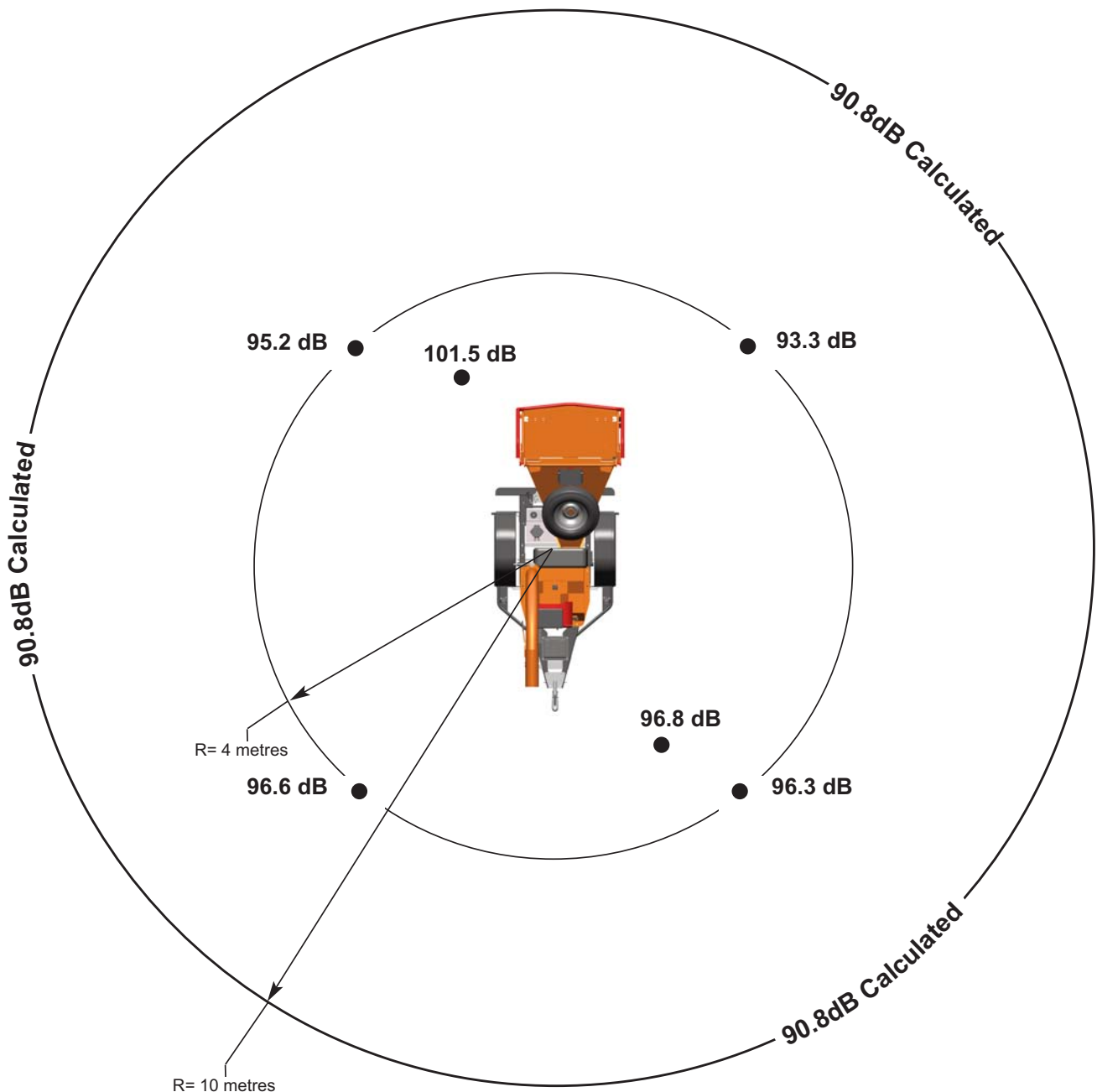

Guaranteed Sound Power: 120dB (A)

As required by Supply of Machinery (safety) regulations of 2008.



SAFE TRANSPORTATION

WARNING

DO NOT RIDE ON THE CHIPPER WHEN IT IS BEING TOWED.



- WHEN towing a chipper the maximum speed limit is 60 mph.
- ON rough or bumpy road surfaces reduce speed accordingly to protect your machine from unnecessary vibration.
- WHEN towing off road be aware of objects that may catch the chipper undergear.
- WHEN towing off road ensure inclination is not excessive.
- AVOID excessively pot holed ground.
- WHEN reversing the chipper the short wheel base will react quickly to steering.
- ALWAYS check the discharge is tight before moving.
- KEEP tyre pressures inflated to 2.2 bar or 32 psi.
- CHECK wheel nuts are tightened to 90Nm or 65 lbs ft.
- CLEAR loose chippings and debris from the machine before departing.
- ENSURE feed funnel is closed and the catch is properly engaged before departing.

HITCHING ONTO THE TOW BALL

- CHECK ball head is well greased.
- WIND jockey wheel assembly anticlockwise until the tow head is above the height of the ball hitch on the vehicle.
- REVERSE vehicle so the ball hitch is directly below the tow head.
- ATTACH breakaway cable to a strong point on the vehicle, not the ball hitch.
- GRASP handle on tow head and push back catch with thumb.
- WIND jockey wheel assembly clockwise, to lower the tow head onto the ball hitch.
- RELEASE handle and continue to wind jockey wheel clockwise. The tow head should snap into place on the ball hitch. If it doesn't, repeat previous 2 steps.
- WIND jockey wheel up until fully retracted and the jockey wheel frame is seated in its notch on the stem. The chipper weight should be fully on the vehicle.
- RELEASE jockey wheel clamp and slide the jockey wheel assembly fully up.
- TIGHTEN clamp on jockey wheel assembly.
- CONNECT electrical plug to socket on rear of towing vehicle and check operation of all the trailer and vehicle lights.
- THE chipper is now properly attached to the vehicle.

UNHITCHING THE CHIPPER

- ENSURE the chipper will not roll away after being disconnected from the vehicle.
- DISCONNECT the electrical cable from the vehicle socket.
- RELEASE breakaway cable.
- RELEASE the jockey wheel assembly clamp.
- LOWER the jockey wheel assembly fully.
- RETIGHTEN the jockey wheel assembly clamp.
- WIND the jockey wheel assembly anticlockwise until it starts to take the weight of the chipper.
- GRASP the handle and release the catch with your thumb.
- CONTINUE to wind the jockey wheel anticlockwise. This should lift the tow head clear of the ball hitch.
- DRIVE the vehicle clear of the chipper.
- WIND the jockey wheel assembly to a suitable point where the chipper is level.
- THE chipper is now fully detached from the vehicle.



DELIVERY

All Timberwolf TW 150DHB machines have a full pre - delivery inspection before leaving the factory and are ready to use. Read and understand this instruction manual before attempting to operate the chipper. In particular, read pages 5-7 which contain important health and safety information and advice.

OPERATOR'S PERSONAL PROTECTIVE EQUIPMENT REQUIRED

- CHAINSAW safety helmet fitted with visor and recommended ear defenders to an appropriate specification.
- HEAVY-DUTY gloves with elasticated wrist area.
- CLOSE - FITTING heavy-duty non-snag clothing.
- SAFETY footwear.
- FACE MASK (if appropriate).

See page 5 for more detailed information.

MANUAL CONTROLS

Roller control box - is the control box above the feed opening of the chipper funnel. Its function is to control the feed rollers. The feed rollers draw material into the machine. **It does not control the main rotor.**

RED SAFETY BAR = This is the large red bar that surrounds the feed tray and side of the feed funnel. The bar is spring loaded and connected to a switch that will interrupt the power to the rollers. The switch is designed so that it only activates if the bar is pushed to the limit of its travel. The rollers stop instantly, but can be made to turn again by pressing either the **GREEN FEED** or **BLUE REVERSE** control buttons.

RED SAFETY BAR TEST

To ensure the safety bar is always operational it must be activated once before each work session. The rollers will not function until the bar is activated. This procedure must be repeated each time the ignition is switched off.

WARNING

DO NOT remove, jam, disable, bypass, override or otherwise impede the effectiveness of the red safety bar.



GREEN BUTTON = Forward feed - Push the button once - this activates the rollers and will allow you to start chipping (if the rotor speed is high enough).

RED BUTTON = Emergency stop - This button stops the rollers from feeding. It overrides all other buttons or bars and will not allow the other buttons to function until it has been reset. To reset, pull out until it returns to its original position. The forward and reverse buttons will now function.

BLUE BUTTON = Reverse feed - allows you to back material out of the rollers. The rollers will only turn in reverse as long as you keep pressing the button. You do not have to press the STOP button before pressing the GREEN FEED button to recommence feeding.

Control Panel Diagram

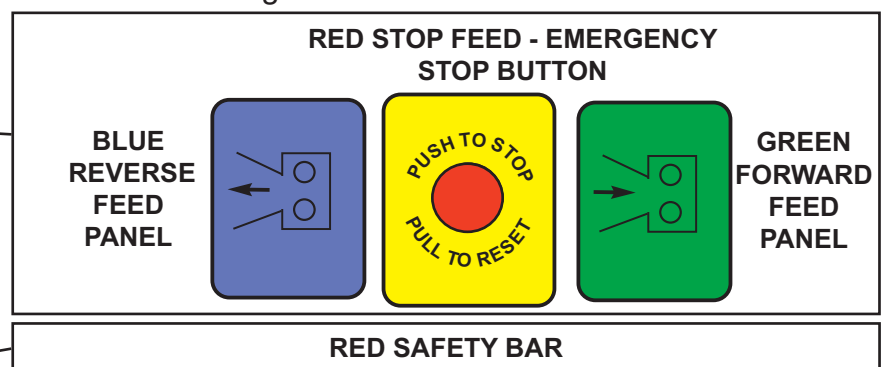

Do not rely on the red bar to keep the rollers stationary if it is necessary to clear or touch the rollers. Always switch off the machine and remove ignition key before approaching the rollers.



AUTO CONTROLS

The no stress unit controls the feed rate of the material going into the chipping chamber. If the rotor speed is below the predetermined level, the no stress unit will not allow the feed rollers to work in either forward or reverse, until the rotor speed rises above the predetermined level. At this point, the feed rollers will start turning without warning.

EMERGENCY STOPPING

Push the **RED STOP** button (see diagram on page 9) or push the **RED SAFETY BAR**, whichever is the **quickest for you to reach**. Turn off the engine ignition key. The emergency stop will prevent any more material being fed into the chipper. The rotor will still be turning. The engine must be powered down to stop the rotor.

ENGINE CONTROLS

The engine speed is controlled by the horizontally adjustable lever shown in the drawing. With the throttle lever in the FAST position the machine is ready to chip. It **MUST** be fully pushed to the left to achieve a suitable working speed. If no wood is to be chipped for a few minutes the throttle should be returned to the idle position.

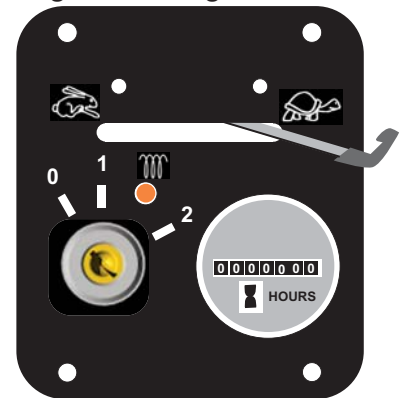

BLADE WEAR

The most important part of using a wood chipper is keeping the cutter blades sharp. Timberwolf chipper blades are hollow ground to an angle of 40 degrees. When performing daily blade checks ensure blade edge is sharp and free from chips, if there is any evidence of damage, or the edge is "dull" change the blade(s). The TW 150DHB is fitted with 2 blades 101mm (4") long. They are 44 mm wide when new. A new blade should chip for up to 25 hours before it requires sharpening. This figure will be drastically reduced by feeding the machine with stony, sandy or muddy material.

As the blade becomes blunt, performance is reduced. With increased stress and load on the machine the chips will become more irregular and stringy. At this point the blade should be sent to a reputable blade sharpening company. The blade can be sharpened several times in its life. A wear mark on the reverse side indicates the safe limit of blade wear. Replace when this line is exceeded.

The machine is also fitted with a static blade (anvil). It is important that the anvil is in good condition to allow the cutting blades to function efficiently. Performance will be poor, even with sharp cutter blades, if the anvil is worn.

HYDRAULIC OIL LEVEL INDICATOR

The oil level will be visible through the tank wall. It should be within the upper and lower level marks.

FUEL LEVEL INDICATOR

The fuel level can be seen through the wall of the plastic tank.

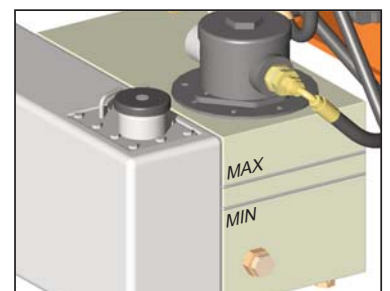

DAILY CHECKS BEFORE STARTING

- LOCATE the machine on firm level ground.
 - CHECK machine is well supported and cannot move.
 - CHECK jack stand is lowered and secure.
 - CHECK all guards are fitted and secure.
 - CHECK the discharge unit is in place and fastened securely.
 - CHECK discharge tube is pointing in a safe direction.
 - CHECK the feed funnel to ensure no objects are inside.
 - CHECK feed tray is in up position - to prevent people reaching rollers.
 - CHECK controls as described on page 11.
 - CHECK (visually) for fluid leaks.
 - CHECK fuel and hydraulic oil levels.
- For parts location see diagrams on pages 3 & 4.*



BEFORE USING THE CHIPPER

IT IS ESSENTIAL TO CARRY OUT THE FOLLOWING TESTS to check safety equipment - this sequence of tests will only take a few seconds to carry out. We recommend that these tests are carried out daily. Observing the function as described will confirm that the safety circuits are working correctly. This is also a good opportunity to remind all operators of the control and emergency stop systems.

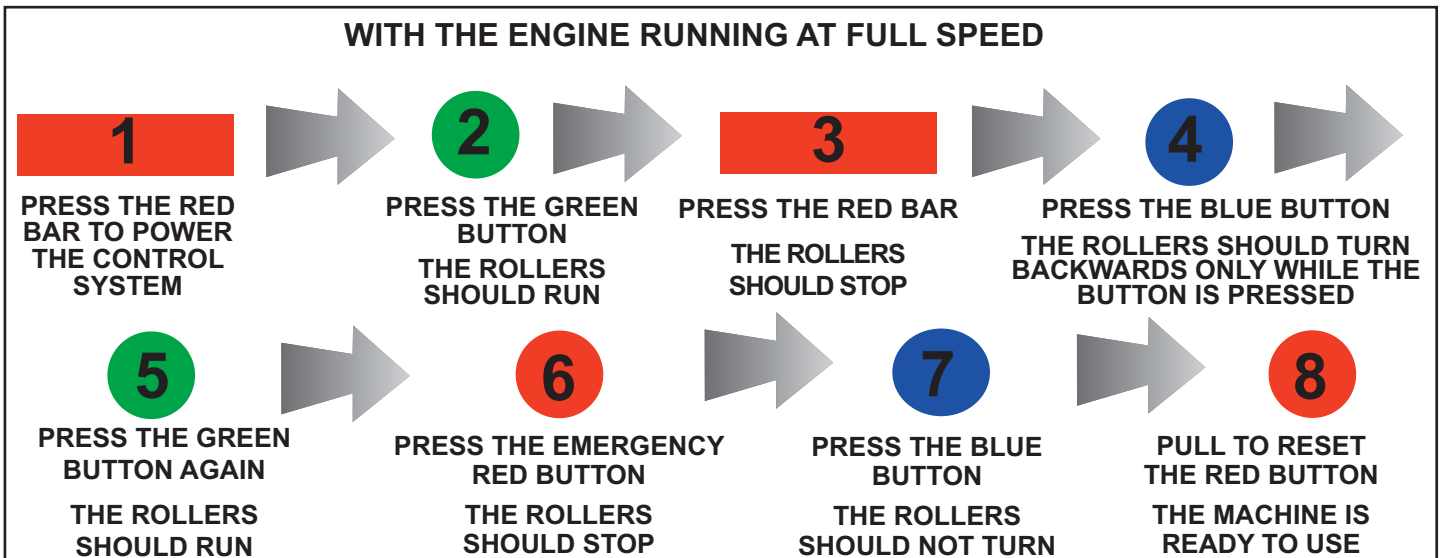

STARTING THE ENGINE

- ENSURE throttle lever is in the slow (tortoise) position.
- INSERT key. Turn to heat.
- HEATER LED comes on.
- WAIT FOR HEATER LED TO GO OUT.
- TURN key to engage starter motor.
- RELEASE key once engine starts.

Do not engage starter motor for more than 20 seconds - allow one minute before attempting to start. Investigate reasons for failure to start.

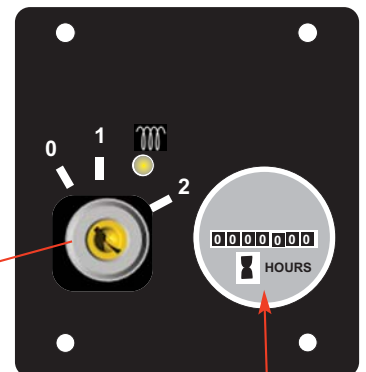

HOURS COUNTER

STOPPING THE ENGINE

- MOVE the throttle lever to the 'Tortoise' to reduce the engine speed to idle.
- LEAVE the engine running for 1 minute.
- TURN the power switch to position 0. The engine should stop after a few seconds.
- REMOVE the ignition key.

For more detailed information refer to the *Engine Owner's Manual*

DISCHARGE CONTROLS

Controlling the discharge is an essential part of safe working.

ROTATION

1. Slacken nut using integral handle.
2. Rotate tube.
3. Retighten nut.

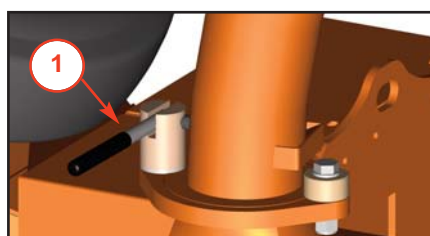

BUCKET ANGLE

4. Adjust the bucket to the desired angle using the handle provided.

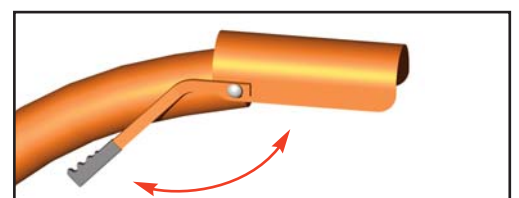



STARTING TO CHIP

WARNING

Do not use or attempt to start the chipper without the protective guarding and discharge unit securely in place. Failure to do so may result in personal injury or loss of life.



- CHECK that the chipper is running smoothly.
- RELEASE the catches on the feed tray and lower. Pull to release the red stop button.
- PERFORM the “before using the chipper” tests (see page 11).
- PRESS the green control button. The rollers will commence turning.
- STAND to one side of the feed funnel.
- PROCEED to feed material into the feed funnel.

CHIPPING

Wood up to the recommended diameter can be fed into the feed funnel. Put the butt end in first and engage it with the feed rollers. The hydraulic feed rollers will pull the branch into the machine quite quickly. Large diameter material will have its feed rate automatically controlled by the no stress unit.

Sometimes a piece of wood that is a particularly awkward shape is too strong for the feed rollers to break. This will cause the top roller to either bounce up and down on the wood, or both rollers to stall. If this occurs, press the **BLUE REVERSE** button until the material has been released. Pull the material out of the feed funnel and trim it so the chipper can handle it.

Both feed rollers should always turn at the same speed. If one or both rollers stop or suddenly slow down it may be that a piece of wood has become stuck behind one of the rollers. If this occurs, press the **BLUE REVERSE** button and hold for 2 seconds - then repress **GREEN FEED** button. This should enable the rollers to free the offending piece of material and continue rotating at the correct speed. If the rollers continue to stall in the 'forward feed' or 'reverse feed' position push the **RED STOP BUTTON**, turn the engine off, remove the ignition key and investigate.

BLOCKAGES

Always be aware that what you are putting into the chipper must come out. If the chips stop coming out of the discharge tube but the chipper is taking material in - **STOP IMMEDIATELY**. Continuing to feed material into a blocked machine may cause damage and will make it difficult to clear.

If the chipper becomes blocked, proceed as follows:

- STOP the engine and remove the ignition keys.
- REMOVE the discharge tube. Check that it is clear.
- WEARING gloves, reach into the rotor housing and scoop out the majority of the debris causing the blockage.

WARNING

Do not reach into the rotor housing with unprotected hands. There are sharp blades and any small movement of the rotor may cause serious injury.



- REPLACE the discharge tube.
- RESTART the engine and increase to full speed.
- ALLOW machine time to clear excess chips still remaining in rotor housing before you continue feeding brushwood. Feed in a small piece of wood while watching to make sure that it comes out of the discharge. If this does not clear it, repeat the process and carefully inspect the discharge tube to find any obstruction.

NOTE

Continuing to feed the chipper with brushwood once it has become blocked will cause the chipper to compact the chips in the rotor housing and it will be difficult and time consuming to clear.

AVOID THIS SITUATION - WATCH THE DISCHARGE TUBE AT ALL TIMES.



**THE FOLLOWING PAGES DETAIL ONLY
BASIC MAINTENANCE GUIDELINES SPECIFIC
TO YOUR CHIPPER.**



THIS IS NOT A WORKSHOP MANUAL.

THE FOLLOWING GUIDELINES ARE NOT EXHAUSTIVE AND DO NOT EXTEND TO GENERALLY ACCEPTED STANDARDS OF ENGINEERING/MECHANICAL MAINTENANCE THAT SHOULD BE APPLIED TO ANY PIECE OF MECHANICAL EQUIPMENT AND THE CHASSIS TO WHICH IT IS MOUNTED.

AUTHORISED TIMBERWOLF SERVICE AGENTS ARE FULLY TRAINED IN ALL ASPECTS OF TOTAL SERVICE AND MAINTENANCE OF TIMBERWOLF WOOD CHIPPERS. YOU ARE STRONGLY ADVISED TO TAKE YOUR CHIPPER TO AN AUTHORISED AGENT FOR ALL BUT THE MOST ROUTINE MAINTENANCE AND CHECKS.

TIMBERWOLF ACCEPTS NO RESPONSIBILITY FOR THE FAILURE OF THE OWNER/USER OF TIMBERWOLF CHIPPERS TO RECOGNISE GENERALLY ACCEPTED STANDARDS OF ENGINEERING/MECHANICAL MAINTENANCE AND APPLY THEM THROUGHOUT THE MACHINE.

**THE FAILURE TO APPLY GENERALLY ACCEPTED
STANDARDS OF MAINTENANCE, OR THE PERFORMANCE OF
INAPPROPRIATE MAINTENANCE, MAY INVALIDATE
WARRANTY IN WHOLE OR IN PART.**

**PLEASE REFER TO YOUR AUTHORISED
TIMBERWOLF SERVICE AGENT FOR
SERVICE AND MAINTENANCE.**





SERVICE SCHEDULE

WARNING

Always immobilise the machine by stopping the engine, removing the ignition key and disconnecting the battery before undertaking any maintenance work.



SERVICE SCHEDULE	Daily Check	50 Hours	100 Hours	500 Hours	1 Year
Check water.	✓				
Check radiator is clear.	✓				
Check engine oil - top up if necessary (10W-30).	✓				
Check for engine oil / hydraulic oil leaks.	✓				
Check fuel level.	✓				
Check feed funnel, feed roller cover, access covers, engine covers and discharge unit are securely fitted.	✓				
Check blades.	✓				
Clean air filter element.	DEPENDING ON WORKING ENVIRONMENT				
Check tyre pressure is 2.2 Bar (32 psi).	✓				
Check safety bar mechanism.	✓				
Check for tightness all nuts, bolts and fastenings making sure nothing has worked loose.		✓			
Grease discharge flange.		✓			
Check tension of main drive belts (and tension if necessary).		✓			
Grease the roller box slides.		✓ OR AS REQUIRED - SEE PAGE 20			
Grease the roller spline and bearing.		✓ OR AS REQUIRED - SEE PAGE 20			
Check anvils for wear.		✓			
Check safety bar mechanism.			✓		
Check fuel pipes and clamp bands.			✓		
Check battery electrolyte level.			✓		
Check for loose electrical wiring.			✓		
Replace hydraulic oil filter - every year or 100 hours after service or repair work to the hydraulic system.			✓	OR	✓
Replace hydraulic oil.			✓	OR	✓
Replace fuel pipes and clamp bands.] REFER TO YOUR ENGINE SUPPLIERS MANUAL				
Check coolant.					
Change engine oil.					
Replace engine oil filter cartridge.] RETURN TO DEALER FOR ANVIL CHANGE				
Check valve clearance.					
Replace anvils when worn.] REFER TO SUPPLIERS INSTRUCTION SHEET				
Axle maintenance.					
Tow head maintenance.					

NOTE: Your Timberwolf wood chipper is covered by a full 12 months parts and labour warranty. Subject to correct maintenance and proper machine usage, the bearings are guaranteed for 12 months regardless of hours worked by the machine. In conditions of 'heavy usage' - i.e. in excess of 500 hours per year - it is recommended that the bearings are changed annually to ensure that the machine retains optimum working performance.



SAFE MAINTENANCE

ALWAYS IMMOBILISE THE ENGINE BEFORE UNDERTAKING ANY MAINTENANCE WORK ON THE CHIPPER BY REMOVING THE KEY AND DISCONNECTING THE BATTERY.

- HANDLE blades with extreme caution to avoid injury. Gloves should always be worn when handling the cutter blades.
- THE drive belts should be connected while changing blades, as this will restrict sudden movement of the rotor.
- THE major components of this machine are heavy. Lifting equipment must be used for disassembly.
- CLEAN machines are safer and easier to service.
- AVOID contact with hydraulic oil.

SAFE LIFTING OF THE CHIPPER

The lifting eye is designed to lift the machine's weight only. Do not use hoist hook directly on the lifting eye, use a correctly rated safety shackle. Inspect the lifting eye prior to each use - DO NOT USE LIFTING EYE IF DAMAGED.

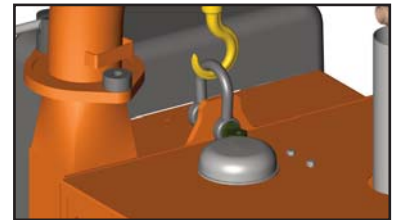

SPARES

Only fit genuine Timberwolf replacement blades, screws and chipper spares. Failure to do so will result in the invalidation of the warranty and may result in damage to the chipper, personal injury or even loss of life.

BATTERY REMOVAL AND MAINTENANCE

WARNING

Refer to the battery safety section on pages 16-17.



1. Open the battery / tool box lid.
2. Remove the negative lead first and then the positive lead.
3. Clean, charge and/or top up the battery as required.
4. Refitting is the reverse of removal. Apply a smear of vaseline to the terminals to prevent corrosion.

CHECK FITTINGS

The Timberwolf TW 150DHB is subject to large vibrations during the normal course of operation. Consequently there is always a possibility that nuts and bolts will work themselves loose. It is important that periodic checks are made to ensure the security of all fasteners. Fasteners should be tightened using a torque wrench to the required torque (see below). **Uncalibrated torque wrenches can be inaccurate by as much as 25%. It is therefore essential that a calibrated torque wrench is used to achieve the tightening torques listed below.**

	Size	Pitch	Head	Torque lbft	Torque Nm
Blade Bolts	M10	Standard	T50 Torx	45	61
Hyd Motor Retaining Nuts	M10	Standard	17mm Hex	34	46
Funnel Retaining Nuts	M12	Standard	17mm Hex	38	51
General	M8	Standard	13 mm Hex	17	23
General	M10	Standard	17 mm Hex	34	46
General	M12	Standard	19 mm Hex	60	80
Drain Bung in Fuel Tank	3/8" BSP	-	22 mm Hex	25	33.8



COPPER EASE SAFETY INFORMATION

Product name: Copper Ease.

Copper Ease contains no hazardous ingredients at or above regulatory disclosure limits, however, safety precautions should be taken when handling (use of oil-resistant gloves and safety glasses are recommended - respiratory protection is not required). Avoid direct contact with the substance and store in a cool, well ventilated area avoiding sources of ignition, strong oxidising agents and strong acids. Dispose of as normal industrial waste (be aware of the possible existence of regional or national regulations regarding disposal), do not discharge into drains or rivers.

In case of fire: in combustion the product emits toxic fumes, extinguish with alcohol or polymer foam, carbon dioxide or dry chemical powder. Wear self-contained breathing apparatus and protective clothing to prevent contact with skin and eyes.

FIRST AID

Skin contact: there may be mild irritation at the site of contact, wash immediately with plenty of soap and water.

Eye contact: there may be irritation and redness, bathe the eye with running water for 15 minutes.

Ingestion: there may be irritation of the throat, do not induce vomiting, wash out mouth with water.

A safety data sheet for this product can be obtained by writing to the manufacturer at the following address: Comma Oil and Chemicals Ltd., Deering Way, Gravesend, Kent DA12 2QX. Tel: 01474 564311, Fax: 01474 333000.

BATTERY SAFETY INFORMATION

WARNING NOTES AND SAFETY REGULATIONS FOR FILLED LEAD-ACID BATTERIES



For safety reasons, wear eye protection when handling a battery.



Keep children away from acid and batteries.



Fires, sparks, naked flames and smoking are prohibited.

-Avoid causing sparks when dealing with cables and electrical equipment, and beware of electrostatic discharges.

-Avoid short circuits, otherwise:



Explosion hazard:

-A highly explosive oxyhydrogen gas mixture is produced when batteries are charged.



Corrosive hazard:

-Battery acid is highly corrosive, therefore:
-Wear protective gloves and eye protection.
-Do not tilt the battery, acid may escape from the vent openings.



First aid:

-Rinse off acid splashed in the eyes immediately for several minutes with clear water! Then consult a doctor immediately.

-Neutralise acid splashes on the skin or clothes immediately with acid neutraliser (soda) or soap suds, and rinse with plenty of water.

-If acid is swallowed, consult a doctor immediately.

Warning notes: The battery case can become brittle, to avoid this:



-Do not store batteries in direct sunlight.

-Discharged batteries may freeze up, therefore store in an area free from frost.



Disposal:

-Dispose of old batteries at an authorised collection point.

-The notes listed under item 1 are to be followed for transport.



Pb

-Never dispose of old batteries in household waste.



BATTERY SAFETY INFORMATION...cont.

1. Storage and transport

- Batteries are filled with acid.
- Always store and transport batteries upright and prevent from tilting so that no acid can escape.
- Store in a cool and dry place.
- Do not remove the protective cap from the positive terminal.
- Run a FIFO (first in-first out) warehouse management system.

2. Initial operation

- The batteries are filled with acid at a density of 1.28g/ml during the manufacturing process and are ready for use.
- Recharge in case of insufficient starting power (cf. section 4).

3. Installation in the vehicle and removal from the vehicle

- Switch off the engine and all electrical equipment.
- When removing, disconnect the negative terminal first.
- Avoid short circuits caused by tools, for example.
- Remove any foreign body from the battery tray, and clamp battery tightly after installation.
- Clean the terminals and clamps, and lubricate slightly with battery grease.
- When installing, first connect the positive terminal, and check the terminal clamps for tight fit.
- After having fitted the battery in the vehicle, remove the protective cap from the positive terminal, and place it on the terminal of the replaced battery in order to prevent short circuits and possible sparks.
- Use parts from the replaced battery, such as the terminal covers, elbows, vent pipe connection and terminal holders (where applicable); use available or supplied filler caps.
- Leave at least one vent open, otherwise there is a danger of explosion. This also applies when old batteries are returned.

4. Charging

- Remove the battery from the vehicle; disconnect the lead of the negative terminal first.
- Ensure good ventilation.
- Use suitable direct current chargers only.
- Connect the positive terminal of the battery to

- the positive output of the charger. Connect the negative terminal accordingly.
- Switch on the charger only after the battery has been connected, and switch off the charger first after charging has been completed.
- Charging current-recommendation: 1/10 ampere of the battery capacity Ah.
- Use a charger with a constant charging voltage of 14.4V for re-charging.
- If the acid temperature rises above 55° Celsius, stop charging.
- The battery is fully charged when the charging voltage has stopped rising for two hours.

5. Maintenance

- Keep the battery clean and dry.
- Use a moist anti-static cloth only to wipe the battery, otherwise there is a danger of explosion.
- Do not open the battery.
- Recharge in case of insufficient starting power (cf. section 4).

6. Jump Starting

- Use the standardised jumper cable in compliance with DIN 72553 only, and follow the operating instructions.
- Use batteries of the same nominal voltage only.
- Switch off the engines of both vehicles.
- First connect the two positive terminals (1) and (2), then connect the negative terminal of the charged battery (3) to a metal part (4) of the vehicle requiring assistance away from the battery.
- Start the engine of the vehicle providing assistance, then start the engine of the vehicle requiring assistance for a maximum of 15 seconds.
- Disconnect the cables in reverse sequence (4-3-2-1).

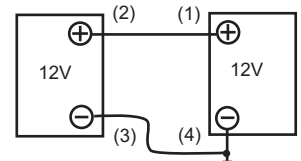

7. Taking the battery out of service

- Charge the battery; store in a cool place or in the vehicle with the negative terminal disconnected.
- Check the battery state of charge at regular intervals, and correct by recharging when necessary (cf. section 4).



CHANGE BLADES

WARNING

Wear riggers gloves for the blade changing operation.

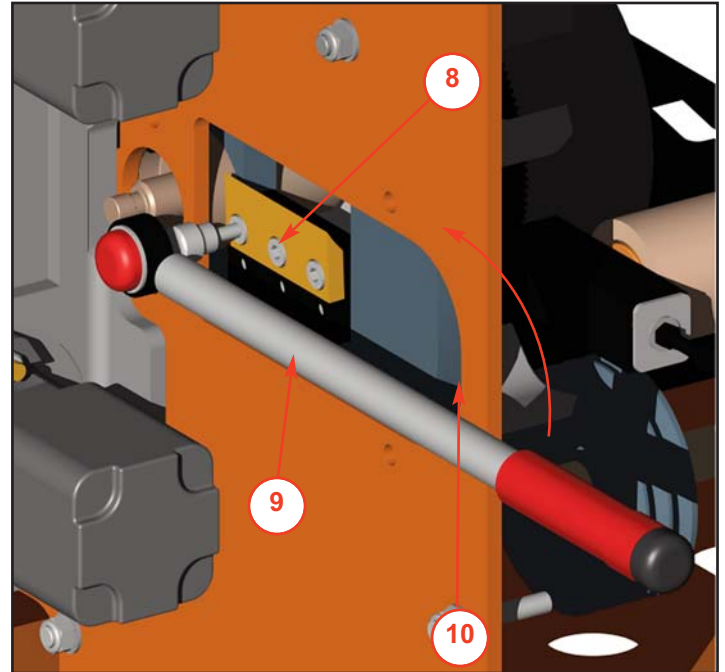
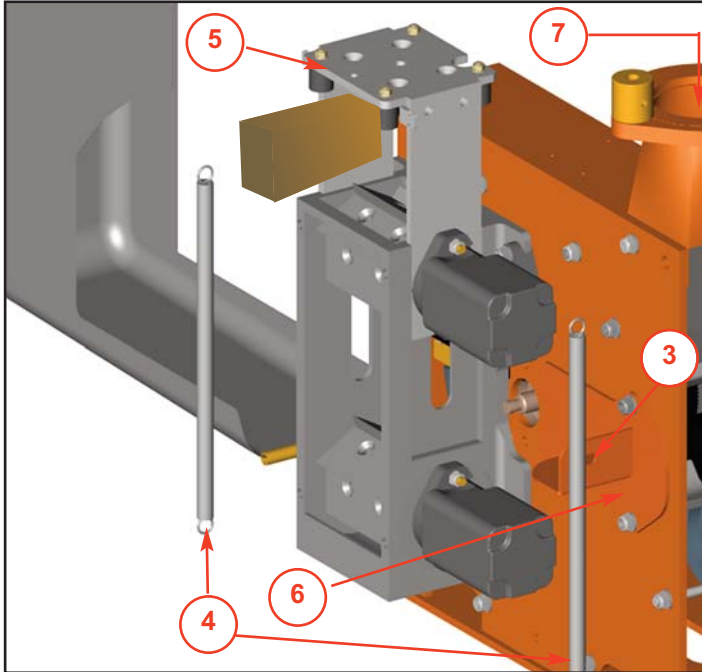

1. Turn the chipper off and remove the ignition keys.
2. Remove battery leads.
3. Remove bolt and washer retaining roller box guard and lift guard.
4. Remove the two springs on the roller box slide.
5. **NOTE: Rollerbox slide weighs in excess of 20kg.** Lift the roller box slide and wedge a suitably sized piece of wood to hold in place.
6. Remove blade access cover.
7. Remove discharge tube. Turn the rotor by hand by grasping fan section on rear of rotor disc until blade is visible through aperture.
8. Use a small screwdriver to remove sap and debris from Torx socket in screw - be particularly careful to ensure every last piece has been removed.
9. Undo blade screws using Torx socket drive provided. Rotor will turn until Torx socket has located on machine.
10. **Before fitting replacement blades carefully clean blade recess in rotor so that no debris is trapped between blade and rotor.**
11. When fitting blades replace any damaged screws with new and coat each screw with copperslip over the whole of the thread.
12. **Retighten each screw to 60Nm (45lbs ft).**
NOTE: This torque setting is vitally important to ensure your bolts come out at a later date and Timberwolf recommend you purchase a torque wrench for this and other jobs on the chipper.
13. Grease all surfaces of the roller box sliding mechanism (see diagram on page 20).
14. Replace blade access cover.
15. **NOTE: Rollerbox slide weighs in excess of 20kg.** Remove wedge, lower roller box slide and replace springs.
16. Close roller box guard making sure that it is located over the retaining bracket, and ensure bolt and washer (as note 3) are tightened.
17. Refit battery leads.

WARNING



Always sharpen blades on a regular basis. Failure to do so will cause the machine to under perform and will overload engine and bearings causing machine breakdown. Blades must not be sharpened beyond the wear mark (see diagram). Failure to comply with this could result in machine damage, injury or loss of life.

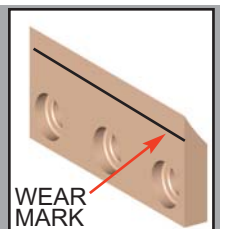



TENSION DRIVE BELTS

NOTE: There will normally be a rapid drop in tension during run-in period for new belts. When new belts are fitted, check the tension every 2 - 3 hours and adjust until the tension remains constant.

Belt failures due to lack of correct tensioning will not be covered under your Timberwolf warranty.

1. Remove side panel.
2. Loosen bolt in centre of tensioner pulley with a 19 mm spanner so that pulley is able to slide with minimal wobble.
3. Turn nut in end of tensioner pulley slider until correct belt tension is achieved. For instructions on checking belt tension & correct belt tension values, please refer to the Timberwolf V-Belt Tensioning Data Table at the end of the manual.
5. Re-tighten bolt in centre of tensioner pulley.
6. Run machine and test, recheck belt tension.
7. **NOTE:** Slack drive belts will cause poor performance and excess belt and pulley wear.

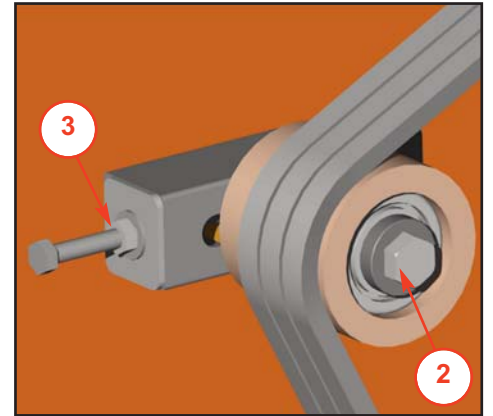

CHANGE HYDRAULIC OIL AND FILTER

WARNING

Use plastic gloves to keep oil off skin and dispose of the used oil and filter in an ecologically sound way. The oil and filter should be changed once a year or at any time it becomes contaminated. Before starting check that the chipper is standing level and brush away loose chips.

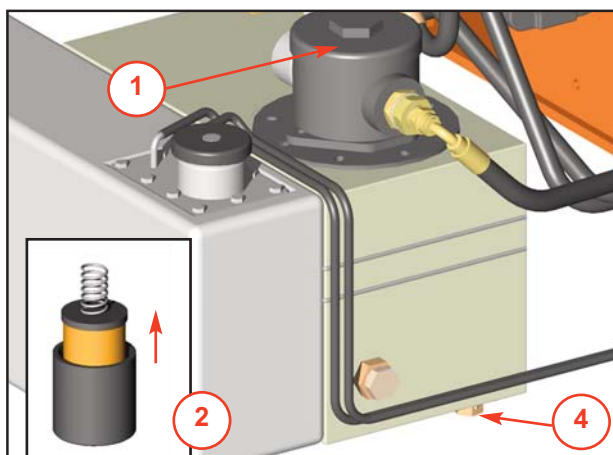

NOTE: This is a non-adjustable air breather filter.

1. Remove the black screw cap from the top of the filter housing.
2. Partially remove filter element from inner cup. Leave filter to drain for 15 minutes.
3. Remove filter element from cup when clear of hydraulic oil.
4. Remove drain plug and drain oil into a suitable container.
5. Replace drain plug.
6. Refill with VG 32 hydraulic oil until the level is between the min and max lines on the tank (about 15 litres).
7. Refit the filter cup, install a new filter element and refit the black screw cap, to the filter housing, ensuring o-ring remains in place.

GREASE THE DISCHARGE FLANGE

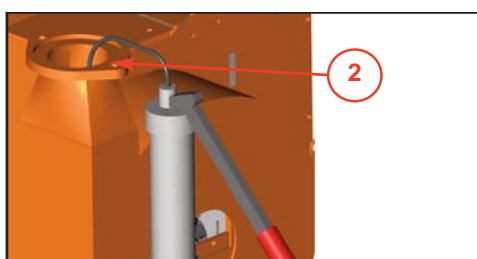

1. Remove the discharge tube.
2. Apply multipurpose grease to surface shown.
3. Refit discharge tube.



GREASE THE ROLLER SPLINE AND BEARING

NOTE: This should be done regularly. In dirty and dusty conditions or during periods of hard work it should be weekly. If the bearings and splines are allowed to run dry premature wear will occur resulting in a breakdown and the need for replacement parts. This failure is not warranty. Early signs of insufficient grease includes squeaking or knocking rollers.

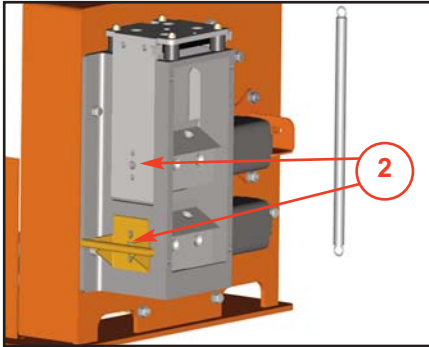

1. Remove bolt and washer retaining roller box guard and lift guard (see diagram on page 18).
2. Locate two grease nipples; one in the centre of each roller shaft.
3. Use a pump action grease gun to apply a generous amount of grease to each roller drive. **DO NOT USE GRAPHITE BASED GREASE.** After applying grease, to penetrate all the bearing surfaces thoroughly, start the machine and operate the rollers for 20 seconds. Switch off the machine. Repeat this greasing/running procedure a further 3 times.
4. Close roller box guard making sure that it is located over the retaining bracket, and ensure bolt and washer are tightened.

GREASE THE ROLLER BOX SLIDES

NOTE: This should be done regularly. In dirty or dusty conditions or during periods of hard work it should be done weekly. If the slides become dry the top roller will tend to hang up and the pulling-in power of the rollers will be much reduced. Excessive wear will ensue.

1. Turn the chipper off and remove the ignition keys.
2. Ensure machine has come to a complete stop - remove battery leads.
3. Remove the bolt and washer retaining roller box guard and lift guard.
4. Remove the two springs on the roller box slide.
5. **NOTE: Rollerbox slide weighs in excess of 20kg.** Lift the top roller and wedge a suitably sized piece of wood to hold in place.
6. Apply thin grease with a brush to each slide on roller box and on inner cheeks of slider. **DO NOT USE GRAPHITE BASED GREASE.**
7. **NOTE: Rollerbox slide weighs in excess of 20kg.** Remove wedge, lower roller box slide and replace springs.
8. Close roller box guard making sure that it is located over the retaining bracket, and ensure bolt and washer (as note 3) are tightened.
9. Refit battery leads.

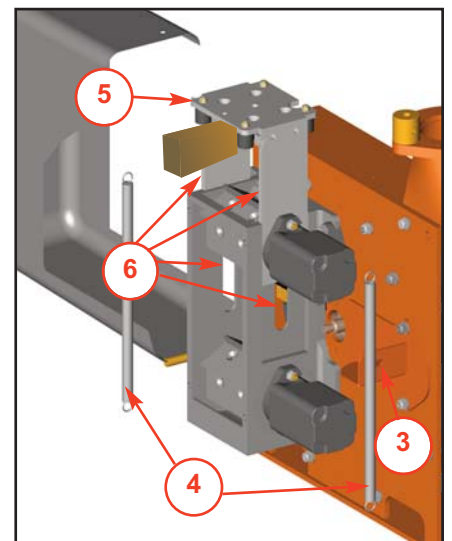

GREASING ROTOR BEARINGS

Both front and rear bearings are sealed and do not need greasing.

ENGINE SERVICING

All engine servicing must be performed in accordance with the Engine Manufacturer's Handbook provided with the machine. **FAILURE TO ADHERE TO THIS MAY INVALIDATE WARRANTY AND/OR SHORTEN ENGINE LIFE.**

CHECK HOSES

All the hydraulic hoses should be regularly inspected for chafing and leaks. The hydraulic system is pressurized to 130 Bar and thus the equipment containing it must be kept in good condition.

Identify the hoses that run to the top motor. These have the highest chance of damage as they are constantly moving. If any hydraulic components are changed new seals should be installed during reassembly. Fittings should then be retightened.



ENVIRONMENTAL MANUFACTURING LLP 12 MONTH CHIPPER WARRANTY

WARRANTY PERIOD

The warranty period for the woodchipper commences on the date of sale to the first end user and continues for a period of 12 months. This guarantee is to the first end user only and is not transferable except when an authorised Timberwolf Dealer has a woodchipper registered with Environmental Manufacturing LLP as a hire chipper or long term demonstrator – in these situations they are duly authorised to transfer any remaining warranty period to their first end user. Any warranty offered by the Timberwolf Dealer beyond the original 12 month period will be wholly covered by said Dealer.

LIABILITY

Our obligation under this warranty is limited to repair at Environmental Manufacturing LLP premises or at our option an Environmental Manufacturing LLP approved Timberwolf dealer. No liability will be accepted for special, indirect, incidental, or consequential loss or damages of any kind.

WARRANTY STATEMENT

Environmental Manufacturing LLP warrants to the first end user that;

- Your woodchipper shall be designed, built and equipped, at the point of sale, to meet all current applicable regulations.
- Your chipper shall be free from manufacturing defects both in materials and workmanship in normal service for the period mentioned above.

Warranty will not apply to a failure where normal use has exhausted the life of a component.

Engine units are covered independently by their respective manufacturer warranties.

OWNERS WARRANTY RESPONSIBILITIES

As the owner of an Environmental Manufacturing LLP woodchipper you are responsible for the following;

- Operation of the woodchipper in accordance with the Environmental Manufacturing LLP instruction manual.
- Performance of the required maintenance listed in your Environmental Manufacturing LLP instruction manual.
- In the event of a failure the Environmental Manufacturing LLP authorised Timberwolf dealer is to be notified within 10 days of failure and the equipment is to be made available for unmolested inspection by the dealer technician.

WARRANTY RESTRICTIONS

The Environmental Manufacturing LLP warranty is restricted to the first end user only and is not transferable except when an authorised Timberwolf Dealer has a woodchipper registered with Environmental Manufacturing LLP as a hire chipper or long term demonstrator – in these situations they are duly authorised to transfer any remaining warranty period to their first end user.

The Environmental Manufacturing LLP warranty may be invalidated if any of the following apply;

- The failed parts or assembly is interfered with in any way.
- Normal maintenance has not been performed.
- Incorrect reassembly of components.
- The machine has undergone modifications not approved in writing by Environmental Manufacturing LLP.
- In the case of tractor driven equipment, use has been on an unapproved tractor.
- Conditions of use can be deemed abnormal.
- The machine has been used to perform tasks contrary to those stated in the Environmental Manufacturing LLP instruction manual.

WARRANTY SERVICE

To obtain warranty service please contact your nearest Environmental Manufacturing LLP approved Timberwolf dealer. To obtain details of the nearest facility please contact Environmental Manufacturing LLP at the address on the front of this manual.

These warranty terms are in addition to and not in substitution for and do not affect any right and remedies which an owner might have under statute or at common law against the seller of the goods under the contract by which the owner acquired the goods.



CERTIFICATE OF CONFORMITY

Environmental Manufacturing LLP

Entec House,
Tomo Industrial Estate,
Stowmarket,
Suffolk IP14 5AY

Tel: 01449 765800 Fax: 01449 765801

EC Declaration of Conformity



Environmental Manufacturing LLP as the designer and manufacturer, certifies that the machine stipulated below complies with all the relevant provisions of the:

Machinery Directive; 2006/42/EC (& other relevant directives)

and the National Laws and Regulations adopting these directives.

Designer/Manufacturer : Environmental Manufacturing LLP
Description of Machinery : Self-powered portable machine intended to chip up tree waste prior to disposal.
Model : TW 150DH & DHB
Serial No. : Serial Manufacture

BSI Transposed Harmonised Standards applied: (including parts/clauses of):

BS EN 12100-1: 2003 Safety of Machinery- Basic concepts, BS EN 13857-1: 2008 Safety of Machinery-Safety distances to danger zones, BS EN 60204-1: 1998 Safe electrical practices, BS EN 13732-1:2006 Safety of Machinery – Temperatures of touchable surfaces, BS EN 13849-1: 2008 – Safety of Machinery – Safety related parts of control systems, BS EN 982: 1996 – Safety of Machinery – Hydraulics, BS EN 1088: 1995 – Safety of Machinery – Interlocking devices, BS EN 13525: 2005 – Forestry Machinery – Wood chippers – Safety.



“Responsible” Person empowered to sign:  Mr. Jeff Haines

Position in Company: Technical Director

Date: 1st December 2009



IDENTIFICATION PLATE

		TIMBERWOLF ENVIRONMENTAL MANUFACTURING LLP Entec House, Tomo Industrial Estate, Stowmarket, Suffolk IP14 5AY - UK			
MODEL					
SERIAL NO.					
CARR. TYP/SN.			GROSS WEIGHT		
NOM. PWR			DATE		
			ENVIRONMENTAL MANUFACTURING LLP		
			KG		
			0 - KG		
			1 - KG		
			2 - KG		

EXAMPLE

DECALS



TIMBERWOLF TW 150DHB 24



616 617 670 671 1258

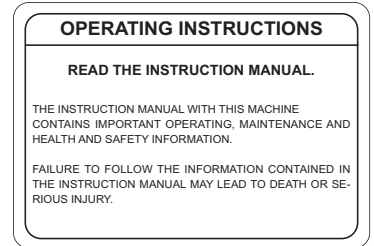

1363 1399 1661 1662

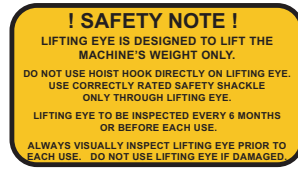
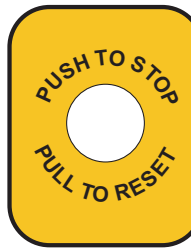
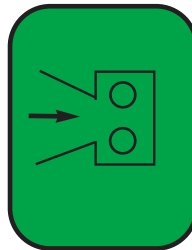
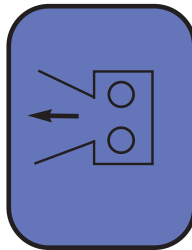
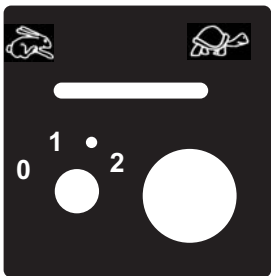

1756 2800 2801 2802 2949 2998

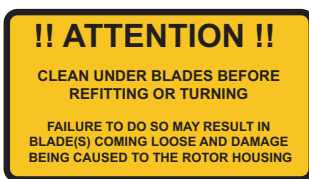

3004 3022 4099 X 2 4138 18393











TIMBERWOLF TW 150DHB

18438 19517 P0000150 x 2



671 - these individual decals are supplied as a set, they may not all apply to your machine.

<p>DANGER</p> <p>DO NOT OPERATE WITHOUT THIS COVER IN PLACE</p> 	<p>DANGER</p> <p>AUTOFEED SYSTEM FITTED. ROLLERS MAY TURN WITHOUT WARNING! WHEN ENGINE IS SWITCHED OFF THE ROLLERS WILL TURN DURING THE RUN DOWN PERIOD</p> 	<p>CAUTION</p> <p>WHEN TRANSPORTING DISCHARGE CLAMPS MAY WORK LOOSE. CHECK FREQUENTLY</p>
<p>DANGER</p> <p>DO NOT OPERATE WITHOUT THIS COVER IN PLACE</p> 	<p>FUEL HERE </p> <p>RISK OF FIRE</p> <p>ALLOW ENGINE TO COOL FOR 1 MINUTE BEFORE REFUELING. USE UNLEADED PETROL</p>	<p>CAUTION</p> <p>AVOID STANDING DIRECTLY IN FRONT OF FEED FUNNEL TO REDUCE EXPOSURE TO NOISE, DUST AND RISK FROM EJECTED PARTICLES</p>
<p>DANGER</p> <p>DO NOT OPERATE WITHOUT THIS COVER IN PLACE</p> 	<p>CAUTION</p> <p>DO NOT PUT ROAD SWEEPINGS IN MACHINE AS GRIT WILL DAMAGE BLADES</p>	<p>DANGER</p> <p>ROTATING BLADES</p> 
<p>DANGER</p> <p>DO NOT OPERATE WITHOUT THIS COVER IN PLACE</p> 	<p>DANGER</p> <p>STOP ENGINE AND REMOVE KEY BEFORE REMOVING DISCHARGE UNIT. ROTATING BLADES INSIDE.</p> 	<p>DANGER</p> <p>DO NOT USE THIS MACHINE WITHOUT THE DISCHARGE UNIT FITTED FAILURE TO COMPLY MAY RESULT IN SERIOUS INJURY OR DAMAGE</p> 

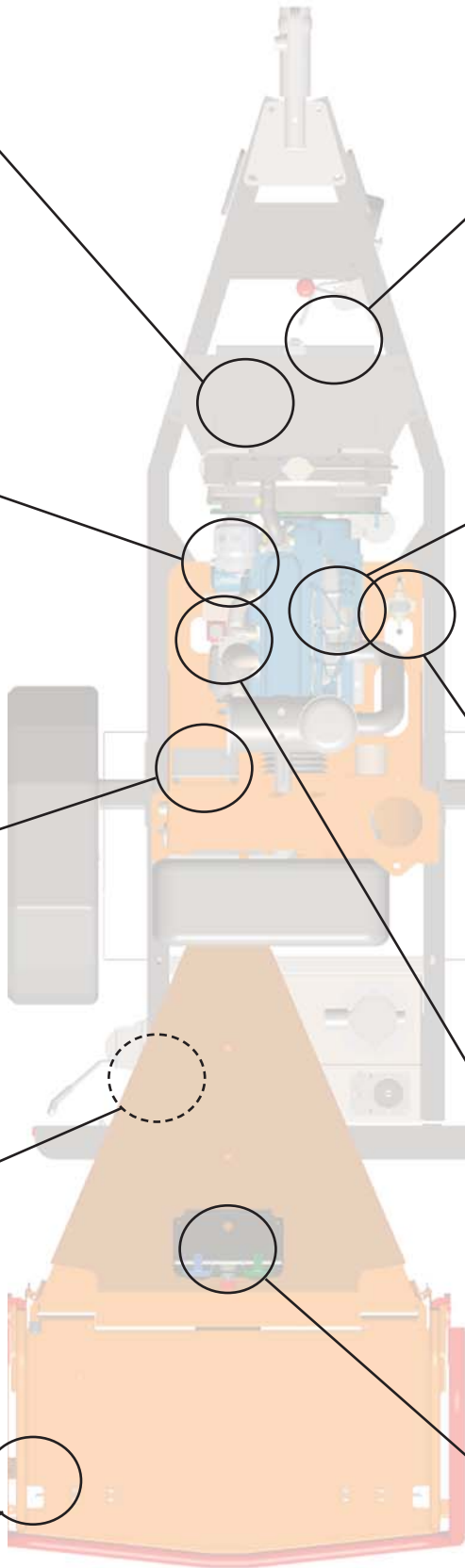
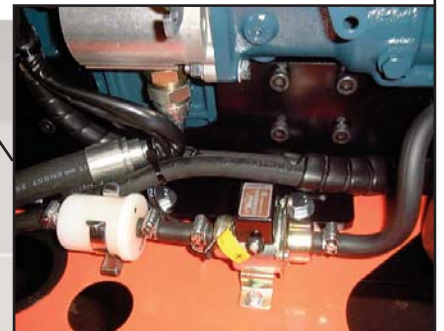
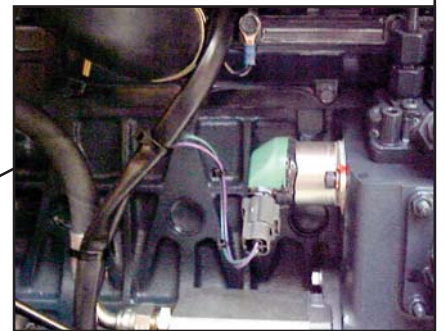

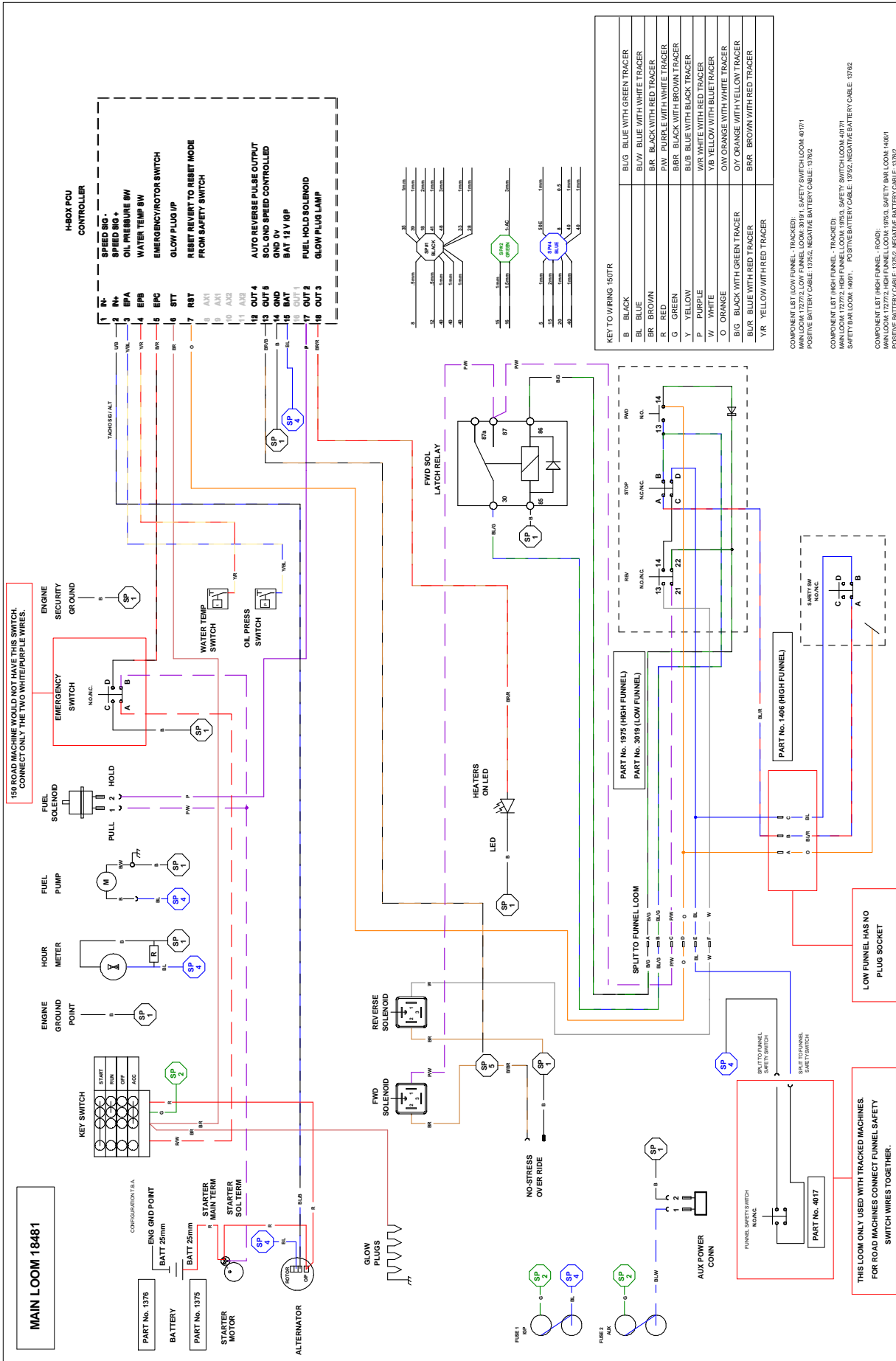

CIRCUIT DIAGRAM FOR: 150 (WITH H-BOX) HIGH AND LOW FUNNEL VERSIONS



Hose Kit 4330

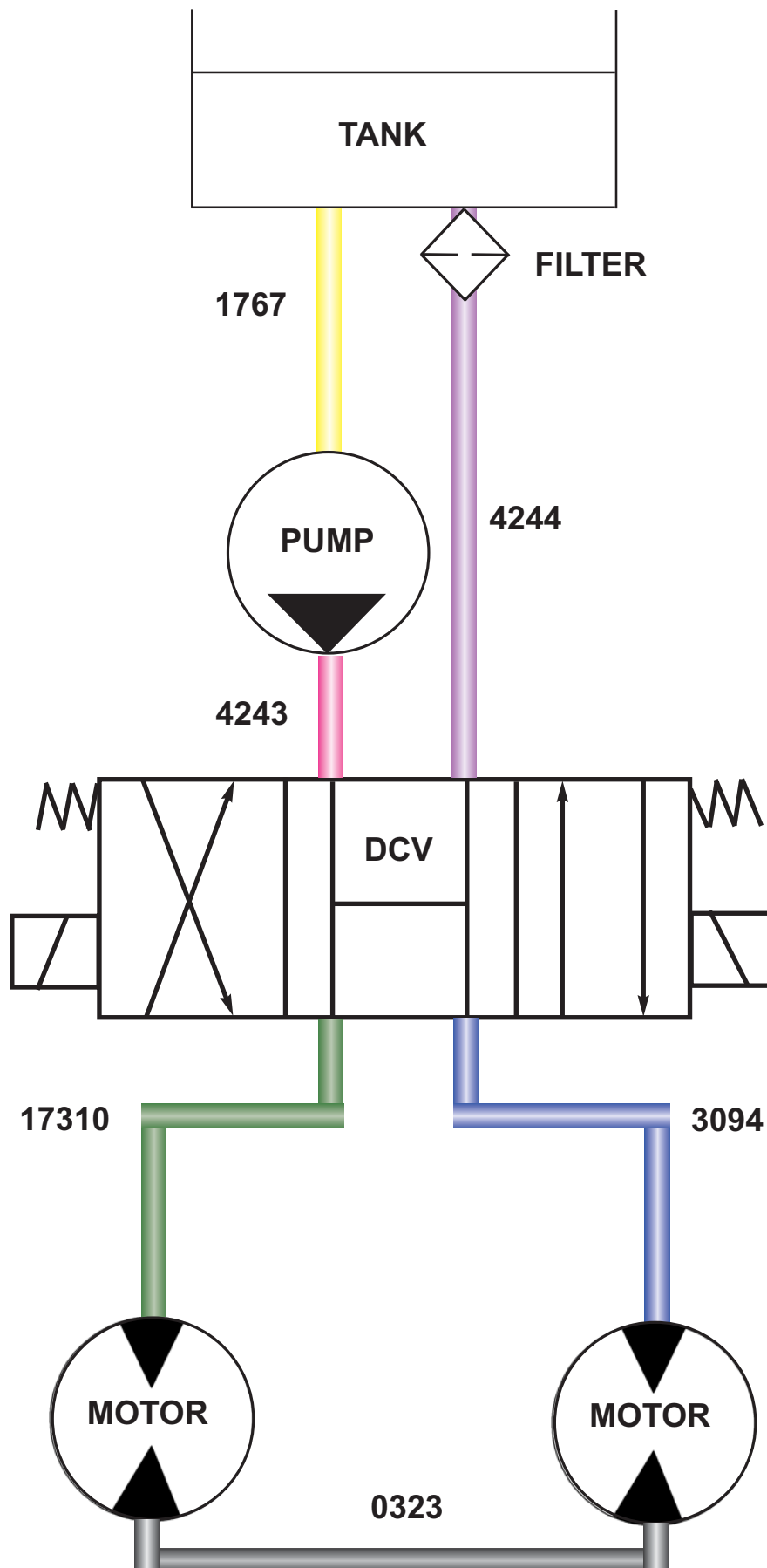

(blank page)



PARTS LISTS

The following illustrations are for parts identification only. The removal or fitting of these parts may cause a hazard and should only be carried out by trained personnel.

	<i>Page No.</i>
BELT TENSIONER	31
CHASSIS (1)	32
CHASSIS (2)	33
CONTROL BOX	34
CONTROL PANEL	35
DECALS	See pages 24 - 25
DISCHARGE	36
DRIVE TRAIN	37
ELECTRICAL LAYOUT	38
ELECTRICAL PANEL	39
ENGINE	40
ENGINE BAY	41
FUEL TANK	42
FUNNEL	43
HYDRAULICS	44
ROLLER BOX	45
ROTOR	46
ROTOR HOUSING	47
V- BELT TENSIONING TABLE	48

31 BELT TENSIONER



TIMBERWOLF
TW 150DHB

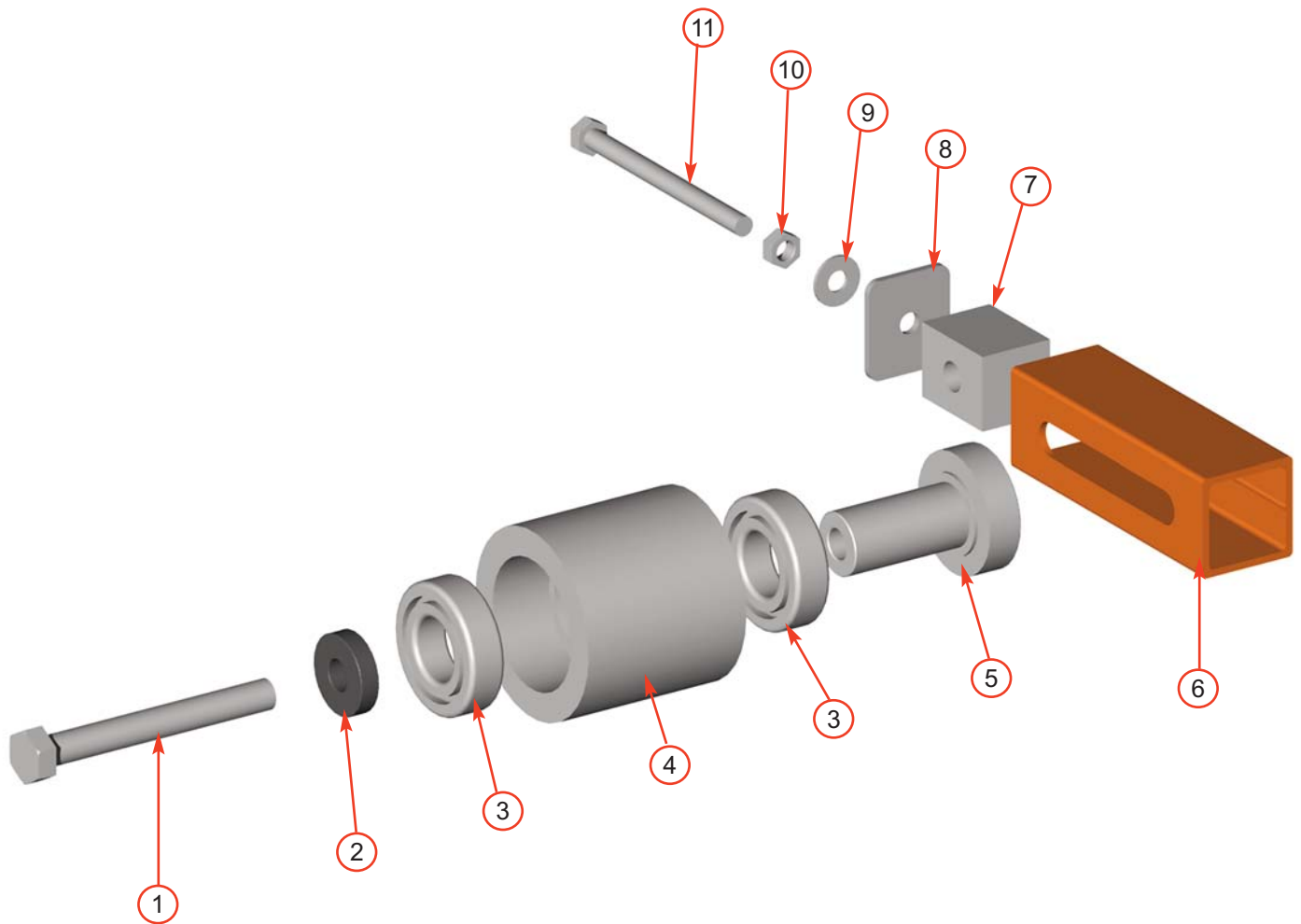

Item	Part No	Part Name	Q'ty
1	0313	M12/100 Bolt	1
2	0415	Heavy Washer	1
3	0491	Bearing 6205	2
4	0411M	Pulley	1
5	0472M	Pulley Boss	1
6	<i>N/A to purchase</i>	Slider	1
7	0469MS	Slider Block	1
8	1342PS	End Plate	1
9	<i>made in production</i>	Washer	1
10	0476	Plain M8 Nut	1
11	2988	M8/90 Bolt	1

Date Last Modified: 17th Aug 05

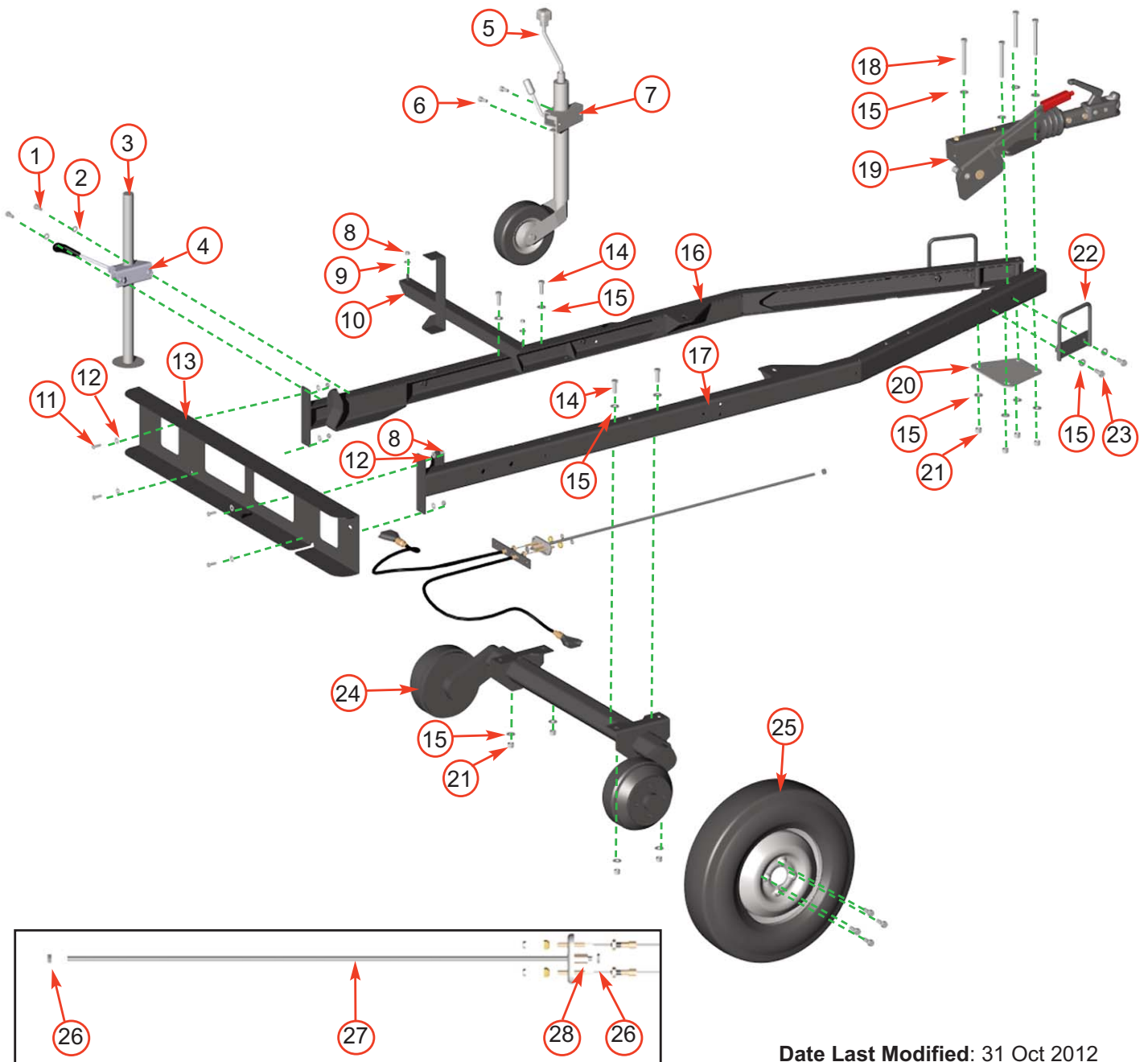

Date Last Modified: 31 Oct 2012

Item	Part No	Part Name	Q'ty	Item	Part No	Part Name	Q'ty
1	0309	M10/40 Bolt	2	15	0704	M12 C Washer	24
2	0701	M10 A Washer	2	16	19802FB	Beam N/S	1
3	0012	Prop Stand	1	17	19803FB	Beam O/S	1
4	0017	34 mm Prop Clamp	1	18	0314	M12/110 Bolt	4
5	P*75	Jockey Wheel Assy	1	19	17479	Tow Head	1
6	0305	M10/25 Caphead	2	20	17509	Brace Plate	1
7	18083	Jockey Wheel Clamp	1	21	0644	M12 P Nyloc Nut	8
8	0479	M8 P Nyloc Nut	6	22	3045FS	Chassis Handle	2
9	0712	M8 C Washer	3	23	1581	M12/35 Caphead	4
10	1701FB	Tank Support	1	24	17483	Axle	1
11	0350	M8/25 Bolt	4	25	19663	Wheel (inc spare)	3
12	0711	M8 A Washer	4	26	1036	M10 Plain Nut	2
13	19804FB	Lightboard Bracket	1	27	4010	Brake Rod	1
14	0430	M12/35 Bolt	4	28	0079F	Nut Ball	1

33 CHASSIS (2)



**TIMBERWOLF
TW 150DHB**

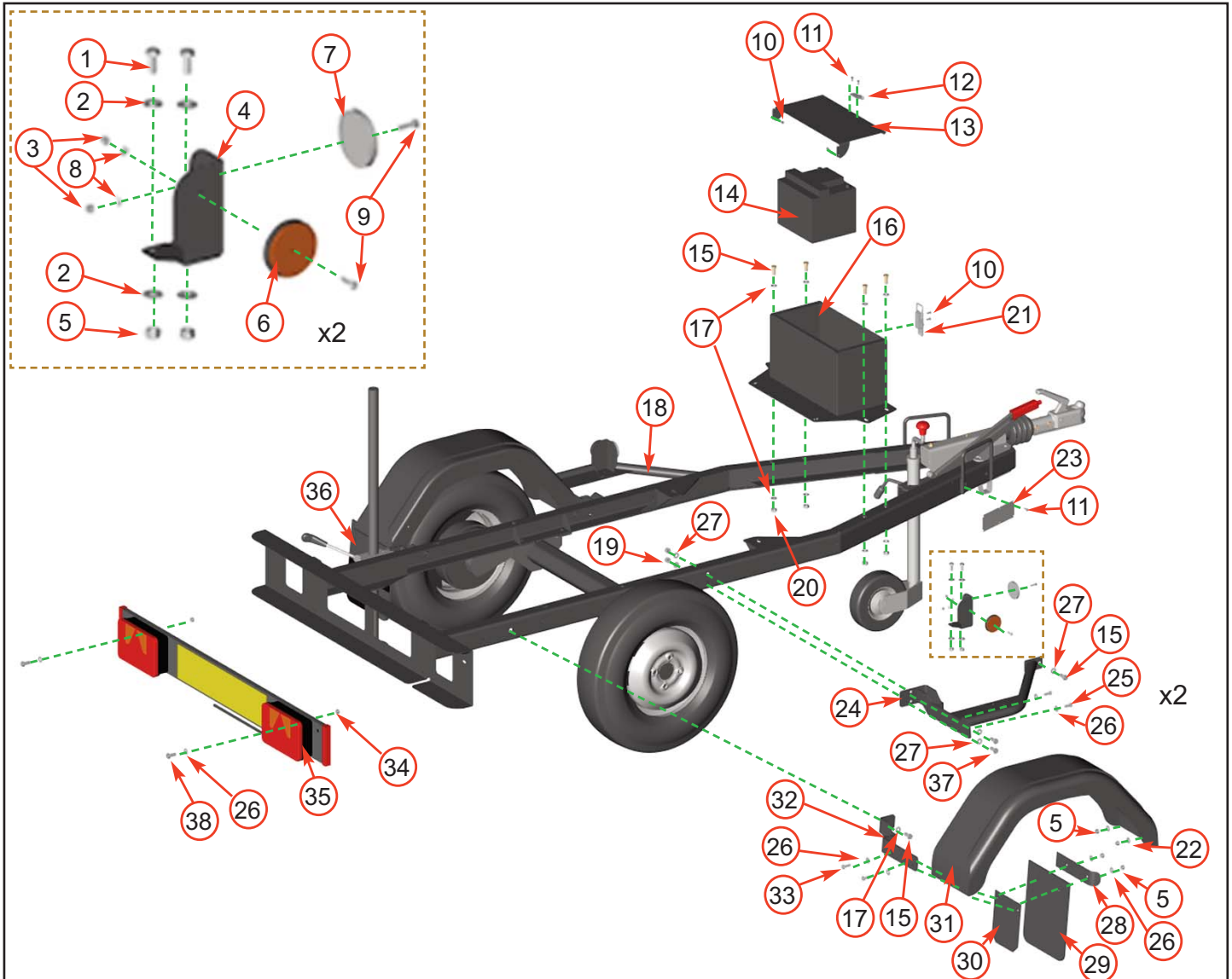

Date Last Modified: 14th June 2012

Item	Part No	Part Name	Q'ty	Item	Part No	Part Name	Q'ty
1	0346	M8/20 Bolt	4	20	0052	M10 T Nyloc Nut	4
2	0711	M8 A Washer	8	21	2963	Catch	1
3	0236	M5 P Nyloc Nut	4	22	0714	M8 Mudguard Washer	4
4	18919	Reflector Support Bracket	2	23	19600	ID Plate	1
5	0481	M8 P Nyloc Nut	12	24	19683	Anti Trap Bar O/S	1
6	18923	Reflector Amber	2	25	0350	M8/25 Bolt	4
7	18922	Reflector Clear	2	26	0712	M8 C Washer	14
8	0857	M5 A Washer	4	27	0701	M10 A Washer	6
9	0435	M5/16 Pan Pozi	4	28	19681	Rain Flap Clamp	2
10	0066	Pop Rivet 4.8 x 6	4	29	19691	Rain Flap	2
11	0067	Pop Rivet 4.8 x 12	6	30	19689	Rain Flap Support	2
12	4088	Catch Plate	1	31	19664	Mudguard	2
13	19645FB	Battery/Tool Box Lid	1	32	19655	Rear Mudguard Bracket O/S	1
14	4210	Battery	1	33	18113	M8/35 Bolt	4
15	0360	M10/25 Bolt	6	34	0479	M8 P Nyloc Nut	2
16	19640FB	Battery/Tool Box	1	35	19795	Lightboard	1
17	0839	M10 C Washer	10	36	19654	Rear Mudguard Bracket N/S	1
18	19682	Anti Trap Bar N/S	1	37	0382	M10/30 Bolt	4
19	4345	M10 P Nyloc Nut	4	38	0352	M8/40 Bolt	2

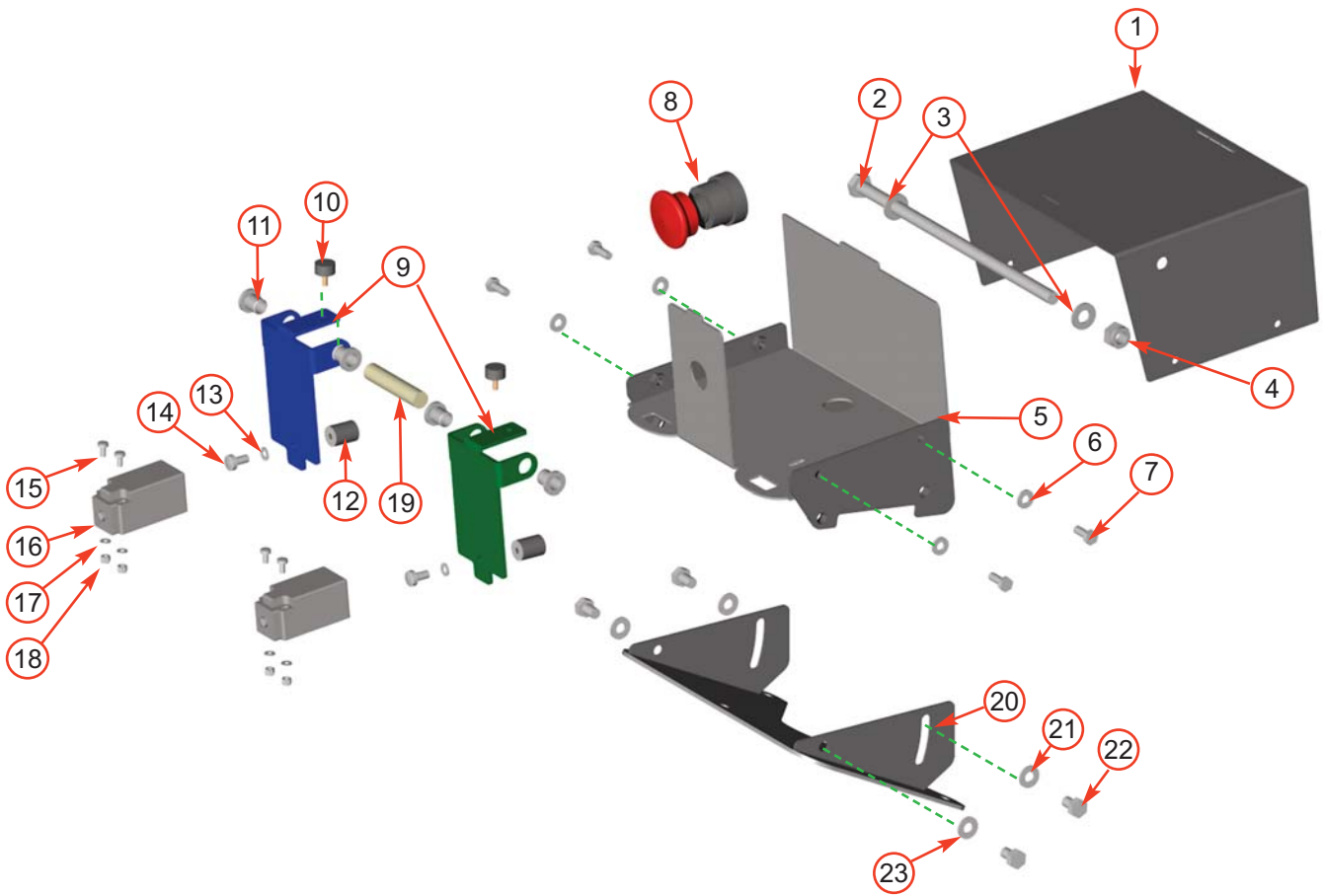

Date Last Modified: 21st July 04

Item	Part No	Part Name	Q'ty	Item	Part No	Part Name	Q'ty
1	2794FB	Control Box Cover	1	13	0857	M5 A Washer	2
2	2803	M10/240 Bolt	1	14	18103	M5/8 Pan Pozi	2
3	0839	M10 C Washer	2	15	18168	M4/35 Pan Pozi	4
4	4345	M10 P Nyloc Nut	1	16	1348	Limit Switch	2
5	2795FB	Control Box Base	1	17	18100	M4 Washer	6
6	0709	M6 C Washer	4	18	18235	M4 P Nyloc Nut	6
7	1658	M6/12 Bolt	4	19	made in production	65mm Spacer	1
8	2853	Stop Switch	1	20	2793FB	Bracket Mounting Control Box	1
9	2796FS	Finger Plate	2	21	0712	M8 C Washer	2
10	2834	AV Mount	2	22	0344	M8/16 Bolt	4
11	2804	Bush M10 Top Hat	4	23	0711	M8 A Washer	2
12	2807	AV Mount 20 x 16	2				

35 CONTROL PANEL



TIMBERWOLF
TW 150DHB

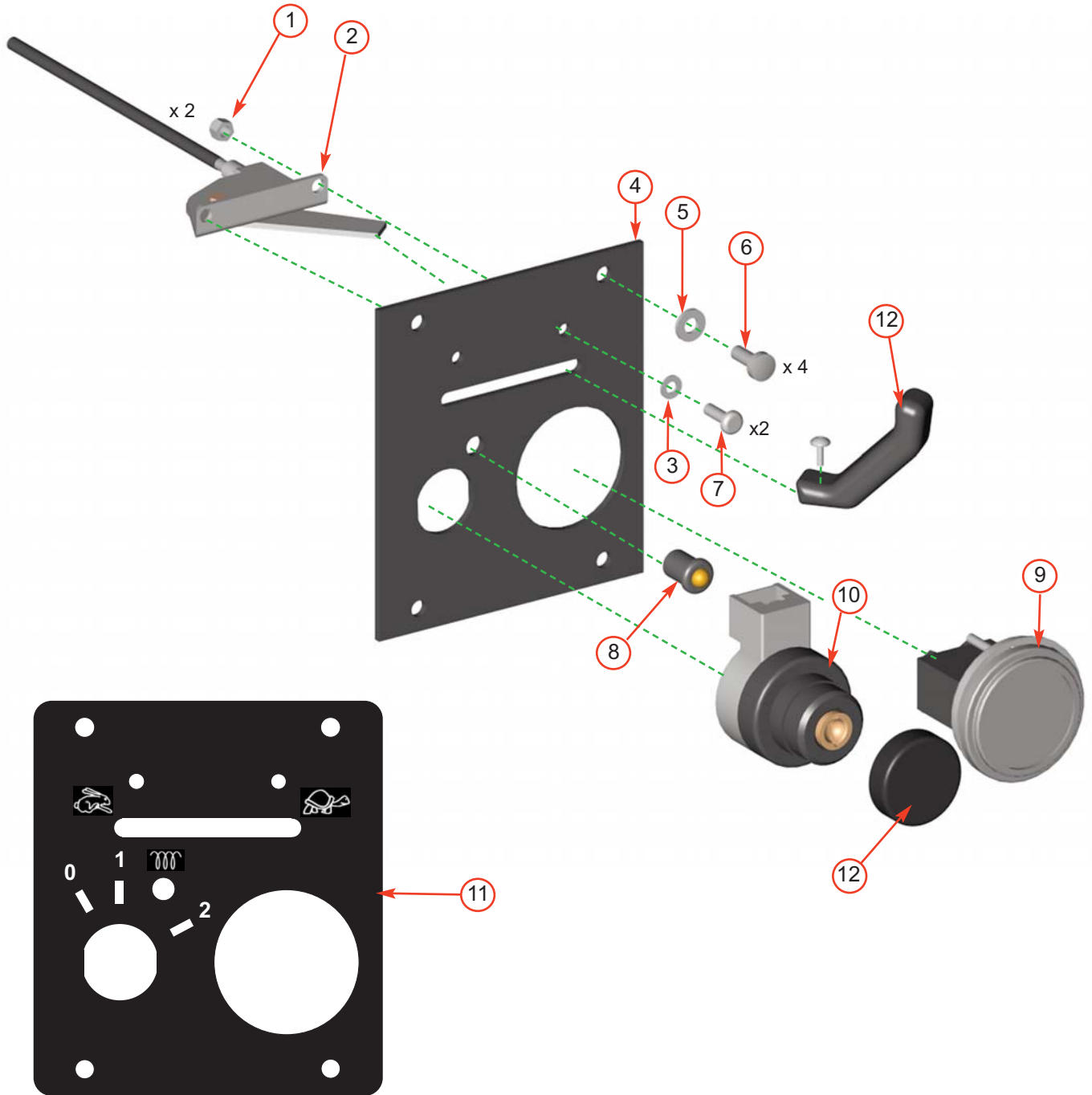

Date Last Modified: 9th July 10

Item	Part No	Part Name	Q'ty	Item	Part No	Part Name	Q'ty
1	0236	M5 P Nyloc Nut	2	8	1757	Amber LED	1
2	0911	Throttle Cable	1	9	0327	Hours Counter	1
3	0708	M5 C Washer	2	10	Supp'd with engine	Ignition Switch	1
4	1758S	Control Panel	1	11	1756	Control Panel Decal	1
5	0709	M6 C Washer	4	12	1397	Throttle Lever	1
6	0438	M6/16 Pan Pozi	4	13	1470	Rubber Protector	1
7	0435	M5/16 Pan Pozi	4				

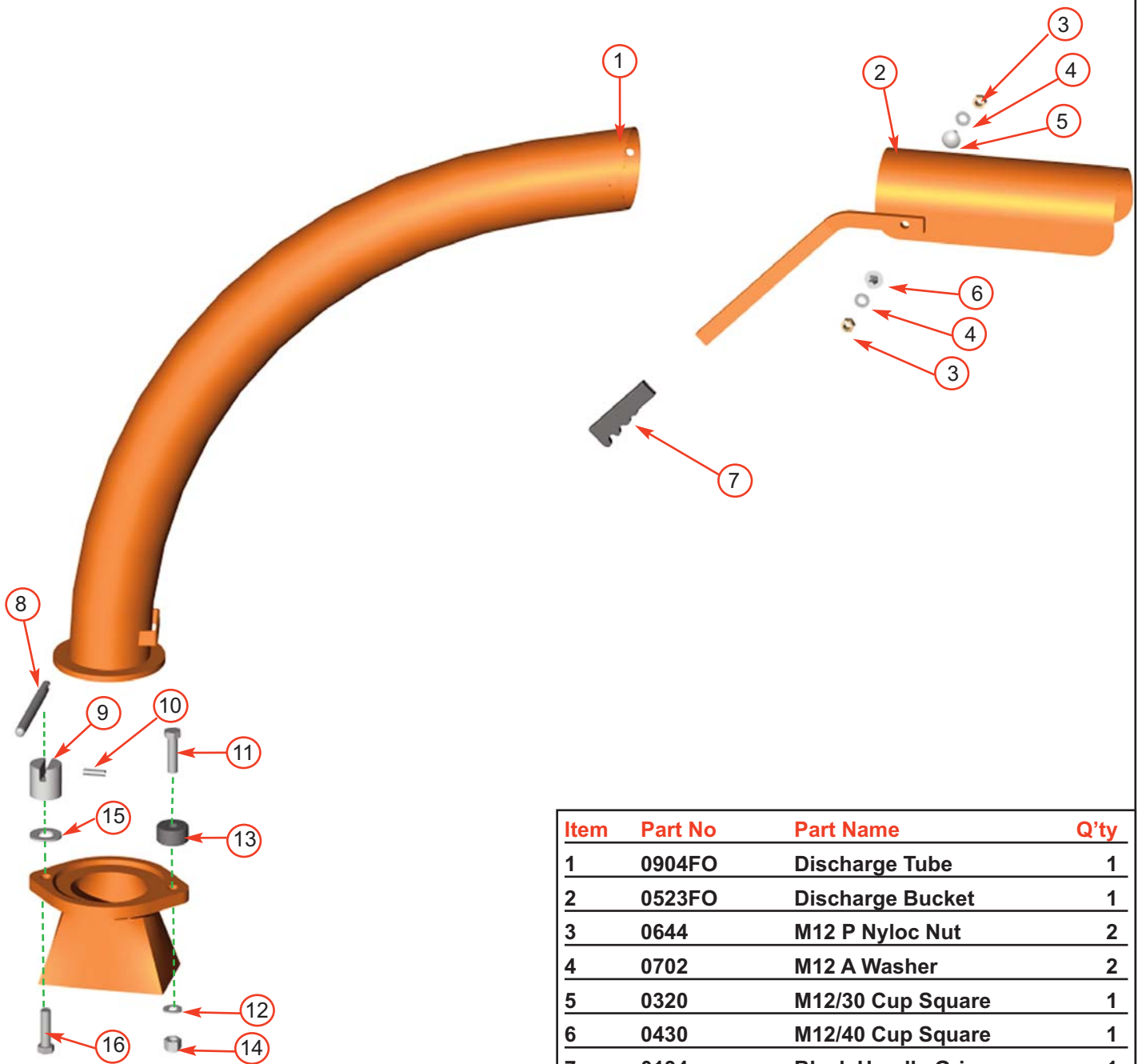

Item	Part No	Part Name	Q'ty
1	0904FO	Discharge Tube	1
2	0523FO	Discharge Bucket	1
3	0644	M12 P Nyloc Nut	2
4	0702	M12 A Washer	2
5	0320	M12/30 Cup Square	1
6	0430	M12/40 Cup Square	1
7	0134	Black Handle Grip	1
8	1649MS	Discharge Clamp Handle	1
9	4109M	M16 Clamp Nut	1
10	4131	Roll Pin	1
11	0434	M16/70 Hex Bolt	1
12	1354	M16 C Washer	1
13	2837M	Clamp Nut Small	1
14	1511	M16 P Nyloc Nut	1
15	0832	M24 Washer	1
16	0333	M16/60 Hex Bolt	1

37 DRIVE TRAIN



TIMBERWOLF
TW 150DHB

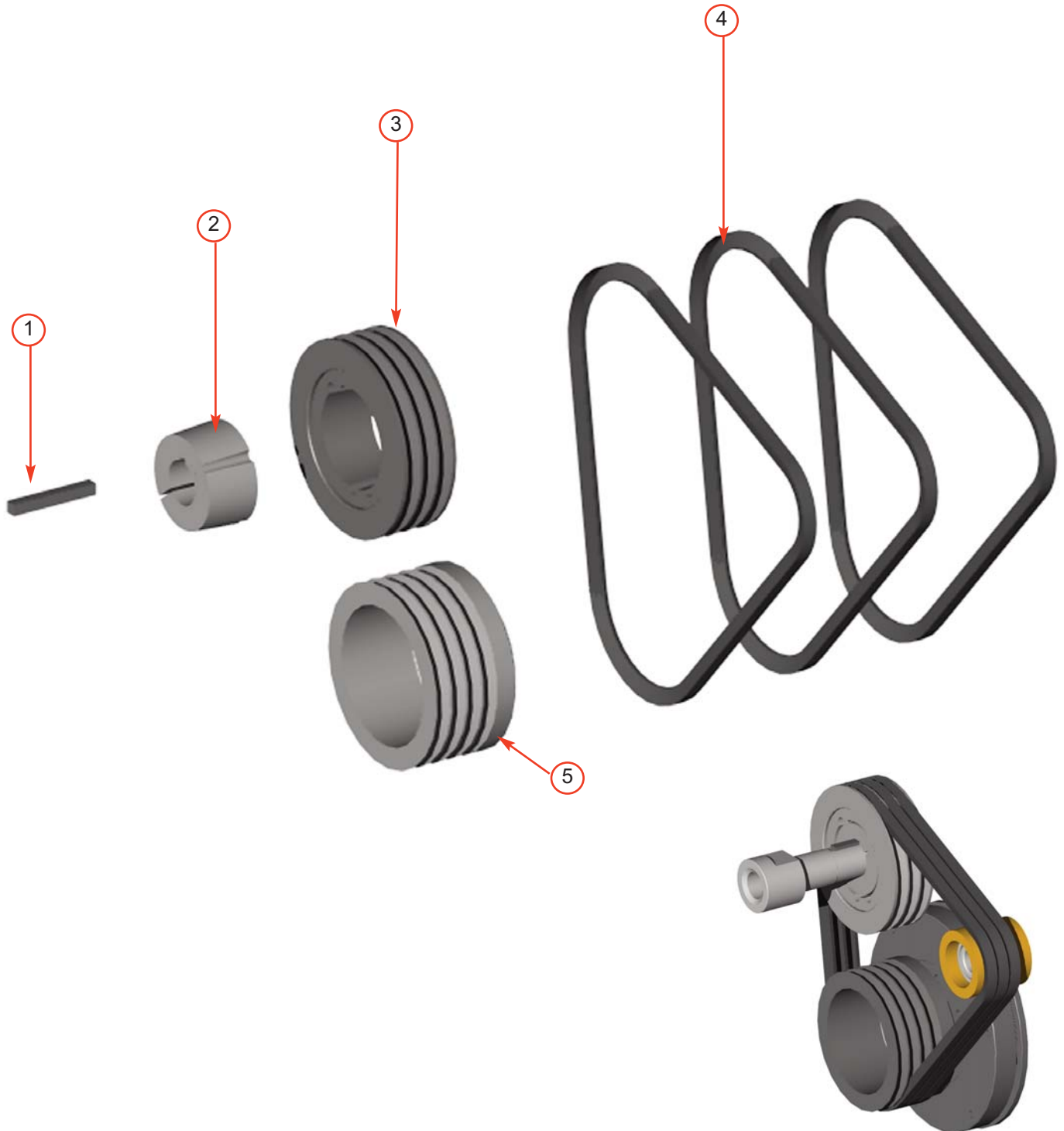

Date Last Modified: 10th Sept 09

Item	Part No	Part Name	Q'ty	Item	Part No	Part Name	Q'ty
1	18961M	Key	1	4	0310	Belt SPA 1060	3
2	0410	Taper Lock Bush 2517	1	5	1170M	Engine Pulley	1
3	1175	Rotor Pulley	1				

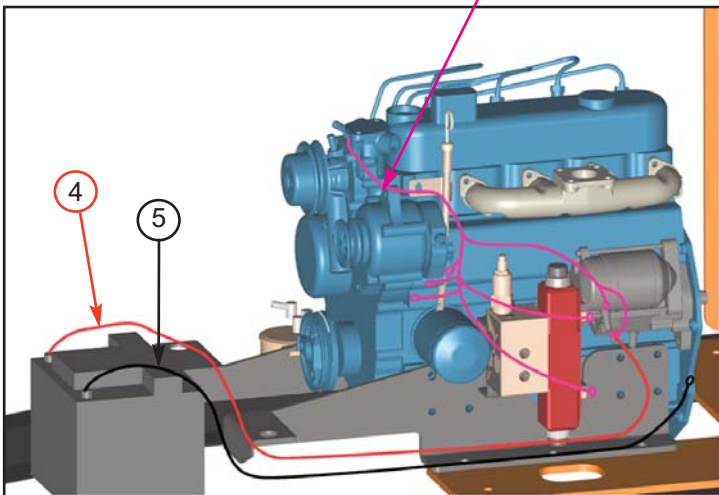
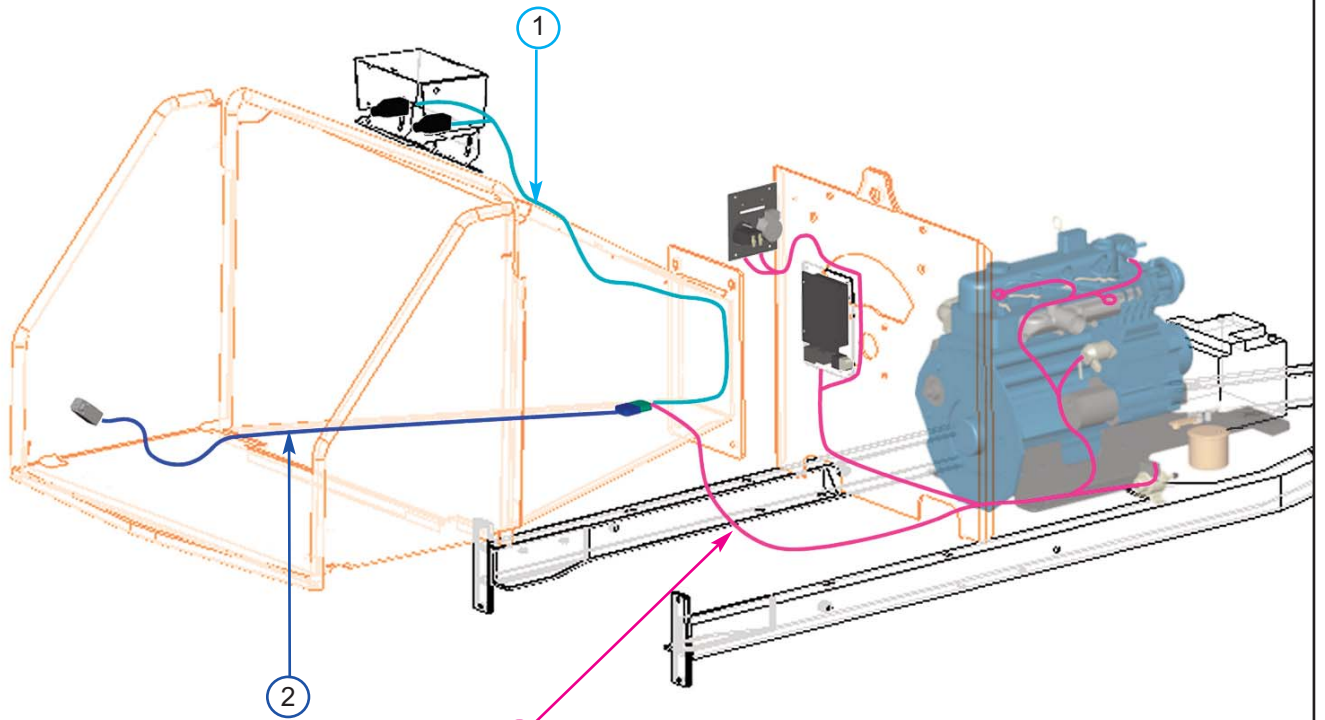

Date Last Modified: 11th March 08

Item	Part No	Part Name	Q'ty	Item	Part No	Part Name	Q'ty
1	1975	Funnel Loom	1	4	1375	+VE Battery Cable	1
2	1406	Safety Bar Loom	1	5	1376	-VE Battery Cable	1
3	18481	Main Engine Loom	1				

39 ELECTRICAL PANEL



TIMBERWOLF
TW 150DHB

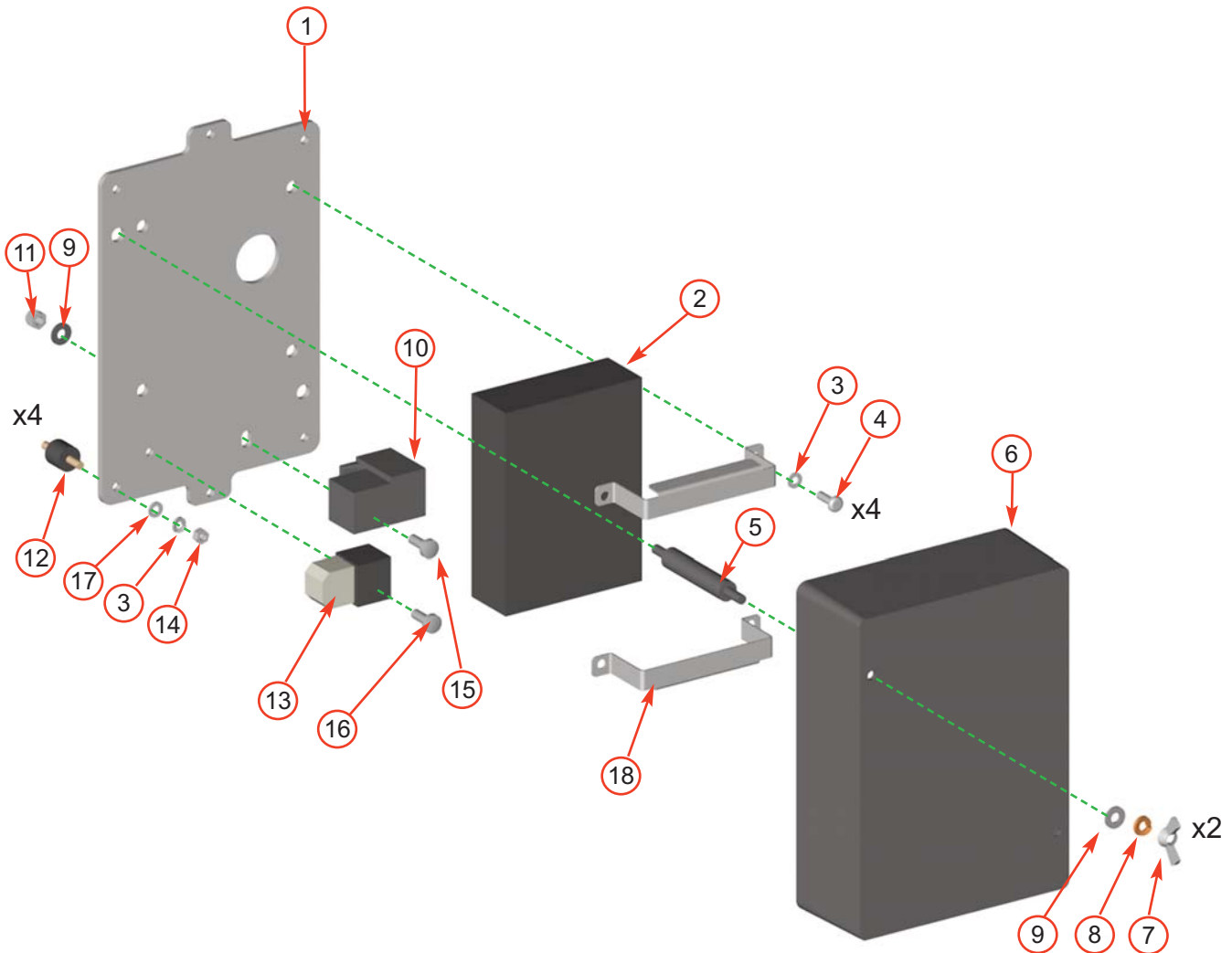

Date Last Modified: 11th March 08

Item	Part No	Part Name	Q'ty	Item	Part No	Part Name	Q'ty
1	3038FS	Electrical Panel	1	10	Supp'd with loom	Relay	1
2	18405	H-Box	1	11	0391	M6 T Nyloc Nut	2
3	0857	M5 A Washer	8	12	4033	M5 AV Mount	4
4	0435	M5/16 Pan Pozi	4	13	Supp'd with loom	Fuse	2
5	2725	Electrical Cover Stand Off	3	14	18291	M5 Plain Nut	4
6	1930	Electrical Cover	1	15	0438	M6/16 Pan Pozi	1
7	18107	M6 Wing Nut	2	16	1151	Countersunk Pop Rivet	1
8	18106	M6 Spring Washer	2	17	3024	M5 Spring Washer	4
9	0709	M6 C Washer	4	18	18398	Mounting Bracket	4

ENGINE



TIMBERWOLF 40
TW 150DHB

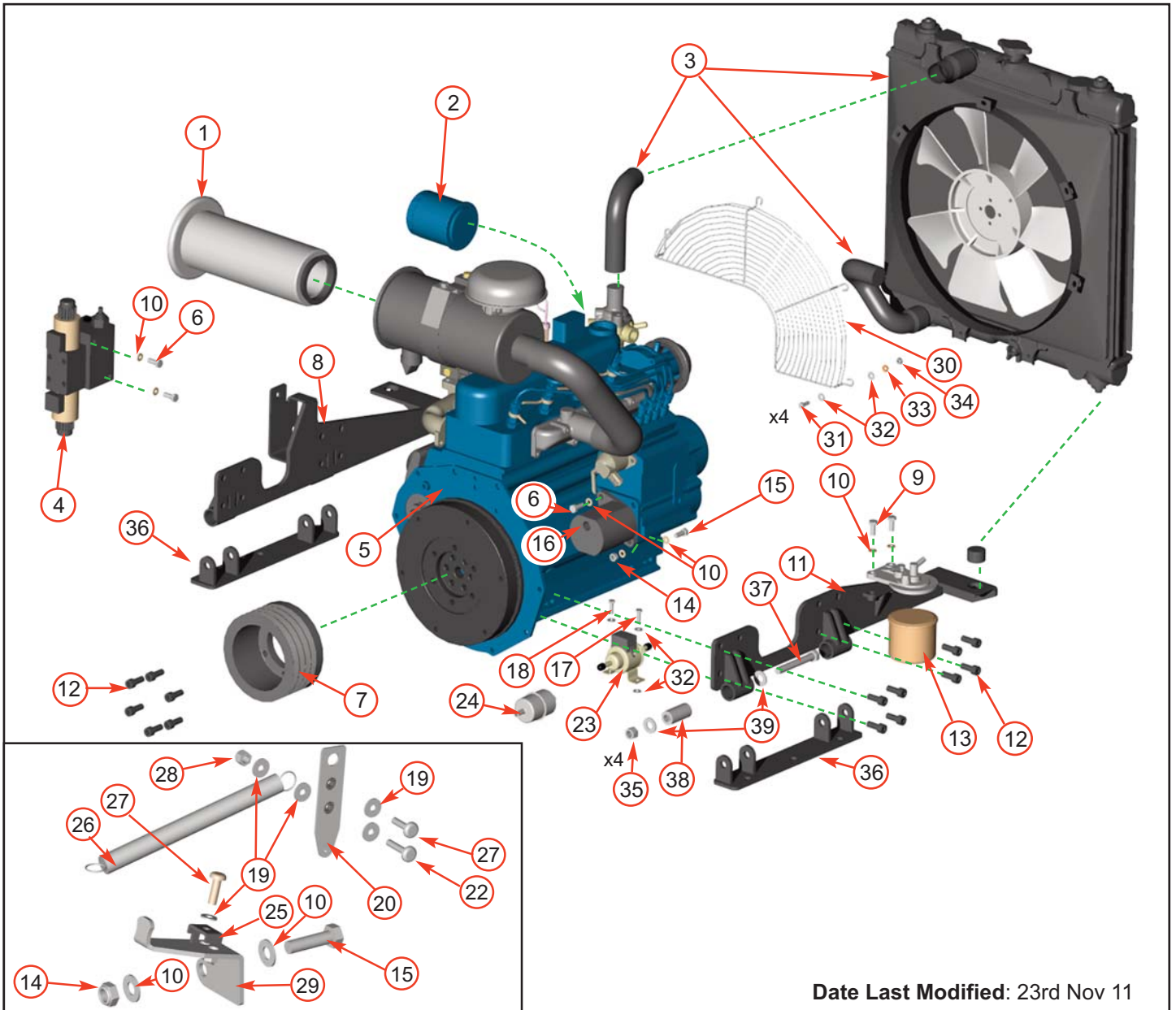

Date Last Modified: 23rd Nov 11

Item	Part No	Part Name	Q'ty	Item	Part No	Part Name	Q'ty
1	0086	Air Filter	1	21	0712	M8 C Washer	3
2	0095	Oil Filter	1	22	0856	M5/20 Pan Pozi	1
3	4319	Radiator Kit	1	23	0807	Fuel Pump	1
4	1613	Directional Control Valve (DCV)	1	24	4315	In-Line Fuel Filter	1
5	0879	Engine	1	25	0699	Throttle Clamp	1
6	0346	M8/20 Bolt	3	26	1304	Spring	1
7	1170M	Pulley Engine 150 x 4	1	27	0435	M5/16 Pan Pozi	2
8	19156FB	Bracket Engine Mount	1	28	0236	M5 P Nyloc Nut	1
9	0350	M8/25 Bolt	2	29	2814FS	Throttle Cable Clamp	1
10	0711	M8 A Washer	8	30	4335	Radiator Fan Guard	1
11	19155FB	Bracket Engine Mount	1	31	0437	M6/16 Bolt	4
12	0304	M10/25 Fine Thread Socket Cap	22	32	0709	M6 C Washer	11
13	0085	Fuel Filter	1	33	18106	M6 Spring Washer	4
14	0481	M8 T Nyloc Nut	2	34	0392	M6 Plain Nut	4
15	0352	M8/40 Bolt	2	35	0644	M12 P Nyloc Nut	4
16	1660	Hydraulic Pump	1	36	18338FS	Engine Bracket Base	2
17	3	M6/25 Bolt	1	37	0332	M12/90 Bolt	4
18	1236	M6/20 Bolt	1	38	18332	AV Mount	4
19	0708	M5 C Washers	5	39	0704	M12 C Washer	8
20	1090F	Throttle Arm Extension	1				

41 ENGINE BAY



TIMBERWOLF
TW 150DHB

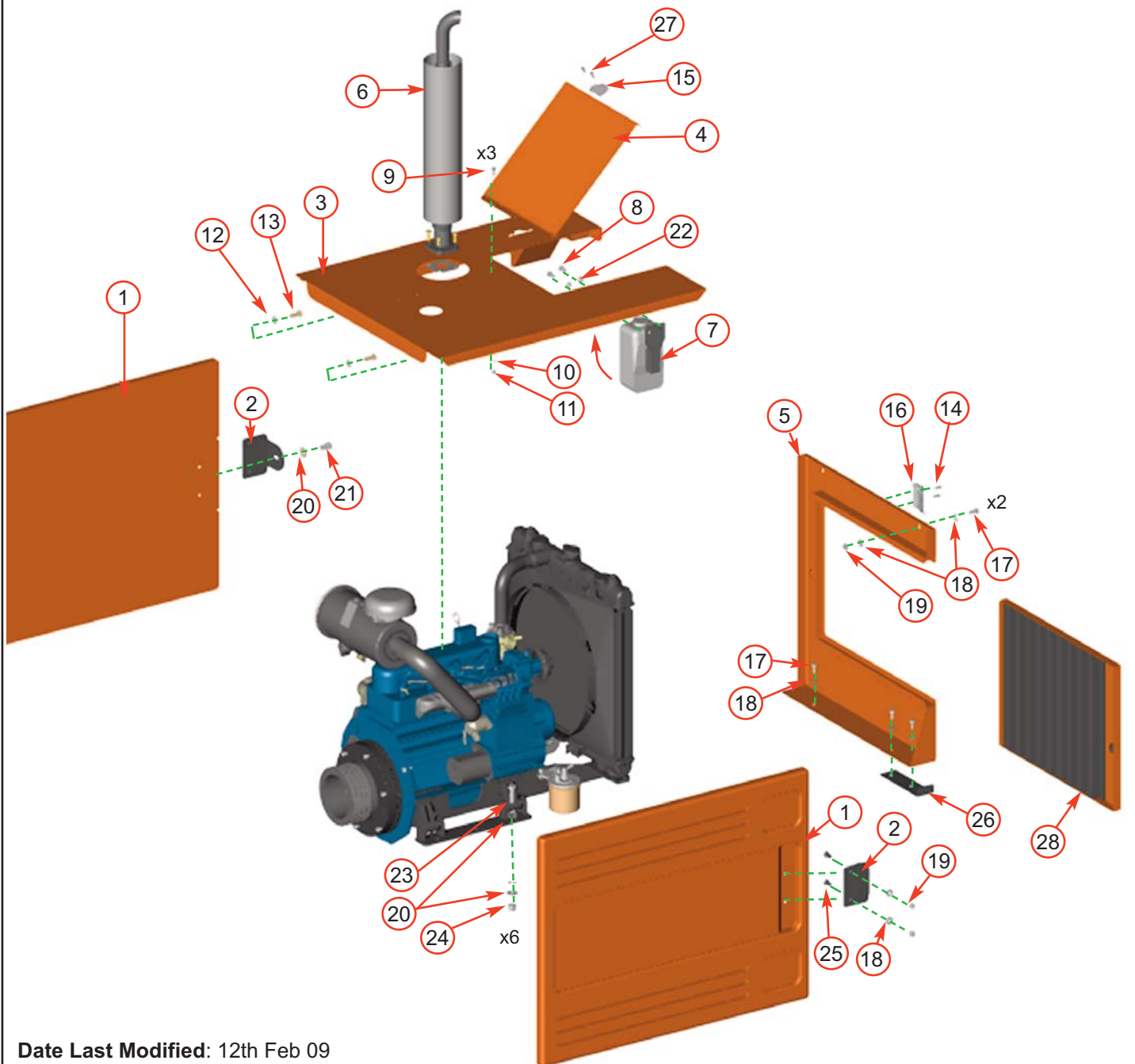

Date Last Modified: 12th Feb 09

Item	Part No	Part Name	Q'ty	Item	Part No	Part Name	Q'ty
1	0765O	Side Panel	2	15	4088	Catch Plate	1
2	0825FS	Handle Side Plastic	2	16	0235	Catch	1
3	17292FO	Top Bonnet	1	17	0346	M8/20 Bolt	5
4	0607FO	Access Cover	1	18	0712	M8 C Washer	14
5	18580FO	Guard Front Engine Bay	1	19	0479	M8 P Nyloc Nut	8
6	18327FB	Exhaust Muffler Complete	1	20	0704	M12 C Washer	14
7	4320	Reserve Tank	1	21	0318	M12/20 Bolt	2
8	0344	M8/16 Bolt	2	22	0711	M8 A Washer	2
9	0438	M6/16 Pozi	3	23	0431	M12/40 Bolt	6
10	0709	M6 C Washer	3	24	0644	M12 P Nyloc Nut	6
11	0391	M6 T Nyloc Nut	3	25	0348	M8/20 Skt Csk Bolt	4
12	0701	M10 A Washer	2	26	17312FB	Side Panel Retainer	1
13	0360	M10/25 Bolt	2	27	0066	Pop Rivet 5 x 6	2
14	0067	Pop Rivet 4.8 x 12	2	28	18581FO	Front Filter Grill	1

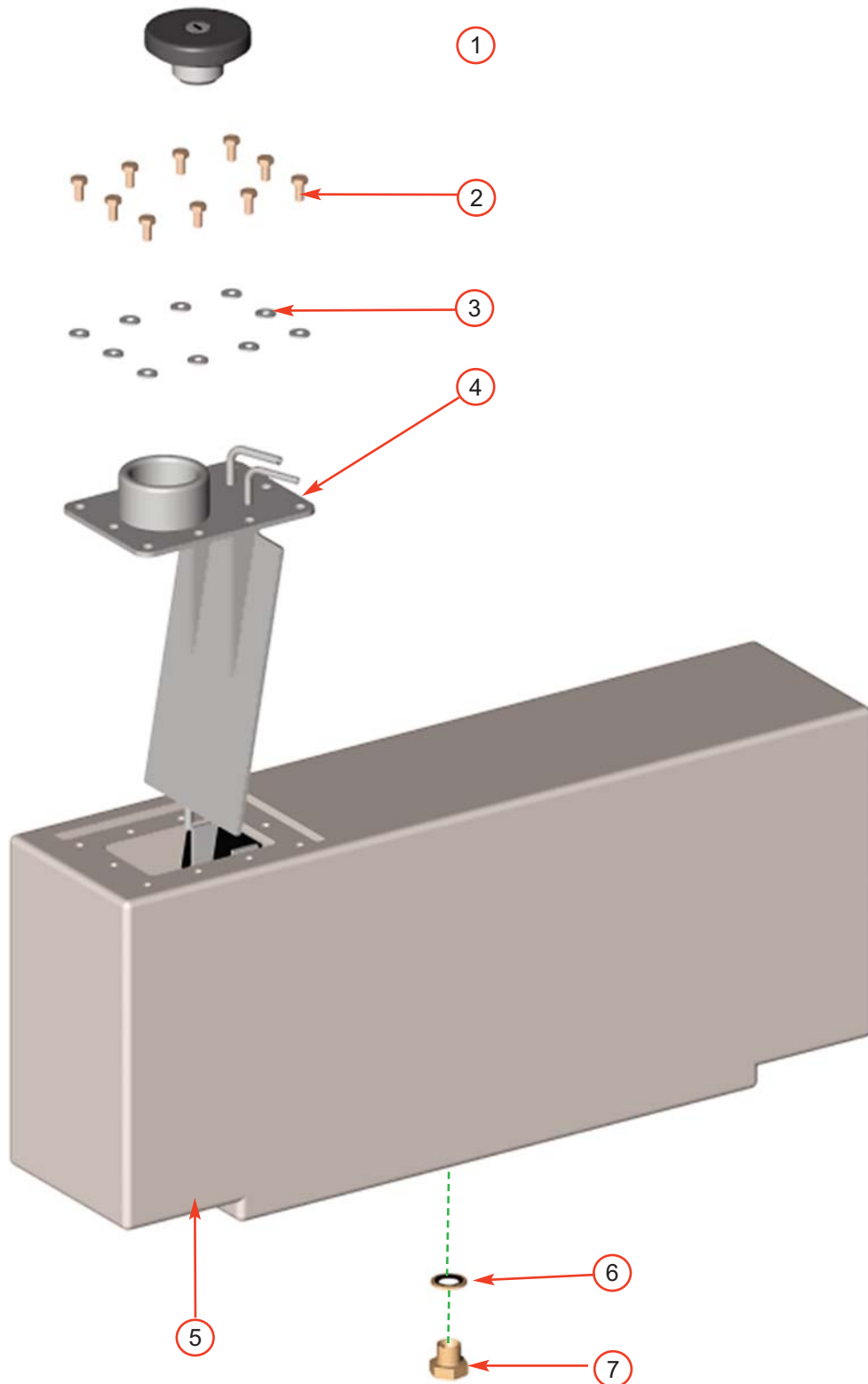

Date Last Modified: 5th Dec 07

Item	Part No	Part Name	Q'ty	Item	Part No	Part Name	Q'ty
1	1374	Locking Tank Cap	1	5	18391K	Fuel Tank Kit (inc. parts 6 & 7)	1
2	1658	M6/12 Bolt	10	6	0396	3/8" Dowty Washer	1
3	0709	M6 C Washer	10	7	0211	3/8" Drain Plug	1
4	1576FS	Tank Top	1				

43 FUNNEL



TIMBERWOLF
TW 150DHB

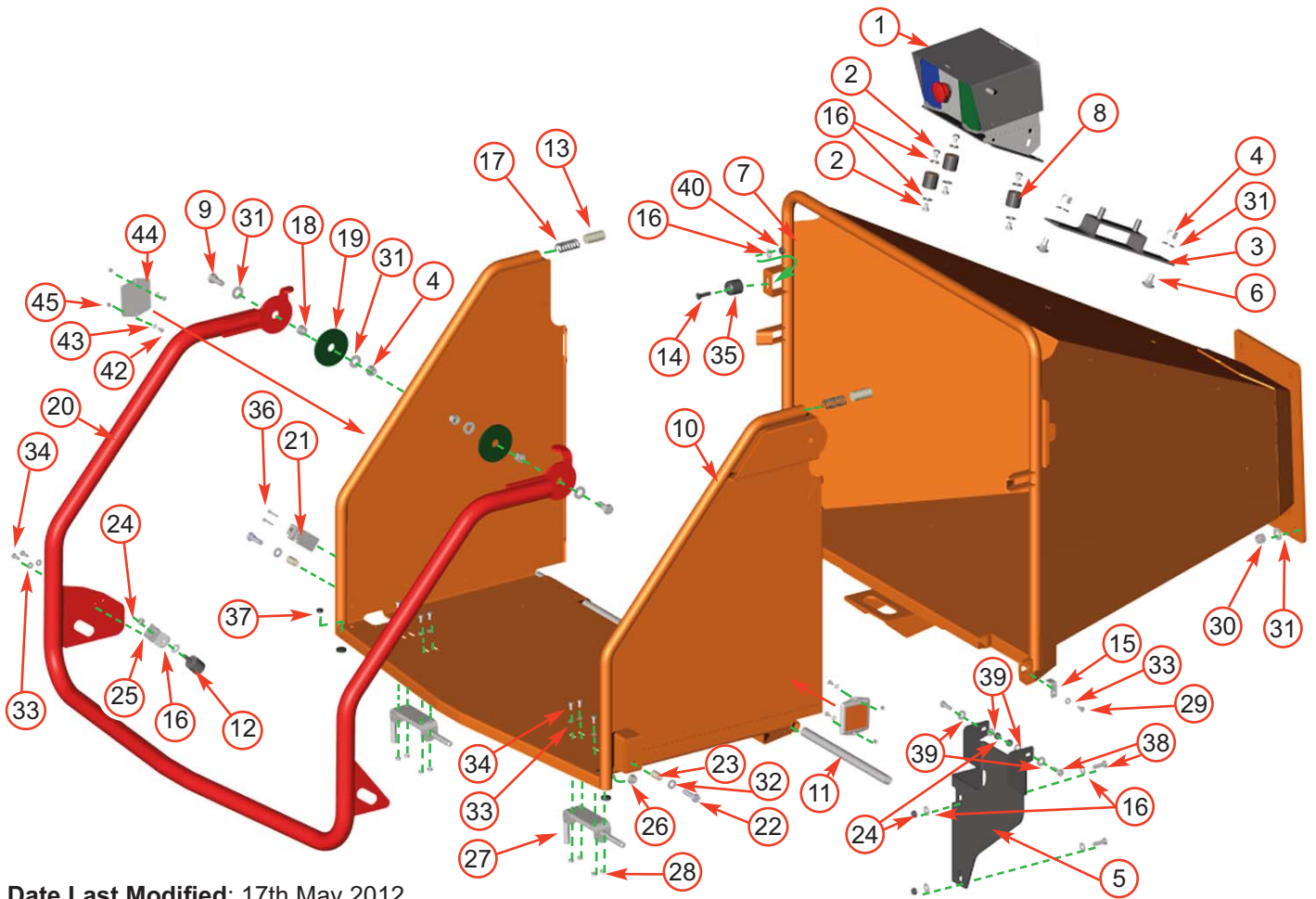

Date Last Modified: 17th May 2012

Item	Part No	Part Name	Q'ty	Item	Part No	Part Name	Q'ty
1	2809F	Control Box (detail on pg 34)	1	24	0479	M8 P Nyloc Nut	5
2	1721	M8/10 Bolt	6	25	2727FS	Bracket Actuator	1
3	0289FS	Spare Wheel Bracket	1	26	4345	M10 P Nyloc Nut	2
4	0045	M12 T Nyloc	4	27	2986	1/2" Spring Bolt	2
5	17451FB	Funnel Support Bracket	1	28	0391	M6 T Nyloc Nut	8
6	0320	M12/25 Cup Square	2	29	1236	M6/20 Bolt	2
7	4238FO	Funnel	1	30	0046	M12 Plain Nut	4
8	1644	M8 Anti-Vibration Mount	3	31	0704	M12 C Washer	8
9	0429	M12/35 Bolt	2	32	4344	M10 Repair Washer	2
10	2919FO	Feed Tray	1	33	0709	M6 C Washer	12
11	2922FS	Hinge Pin	2	34	0437	M6/16 Bolt	10
12	0178	Rubber End Stop	1	35	4206	Nylon Bush	1
13	1600	Nylon Pistons	2	36	1006	M4/30 Pan Pozi	2
14	0353	M8/50 Csk Soc.	1	37	2493	Rubber Cap	2
15	4018S	Pin Bracket	2	38	0350	M8/25 Bolt	4
16	0712	M8 C Washer	12	39	0711	M8 A Washer	4
17	1603	Die Springs	2	40	0481	M8 T Nyloc Nut	1
18	1605M	Stainless Spacer	2	41	19169	M14 C Washer	2
19	1599	Bearing Washer	2	42	18104	M5/12 Pan Pozi	4
20	1570FR	Safety Bar	1	43	0857	M5 A Washer	4
21	1348	Limit Switch	1	44	18924	Square Reflector	2
22	1520	M10/45 Bolt	2	45	18102	M5 T Nyloc Nut	2
23	1591	Nylon Spacer	2				



Date Last Modified: 6th Nov 06

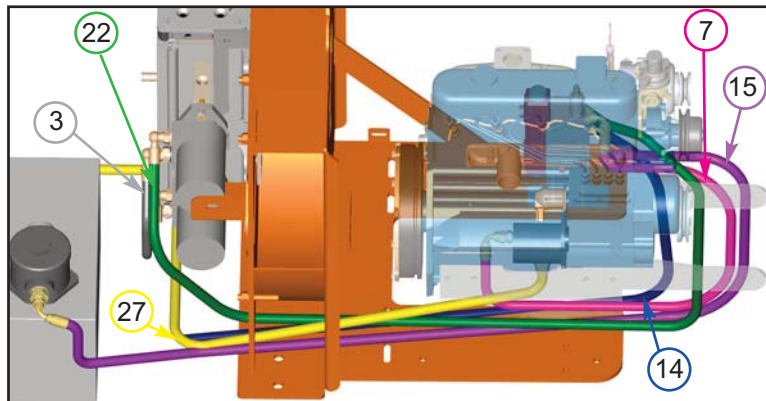
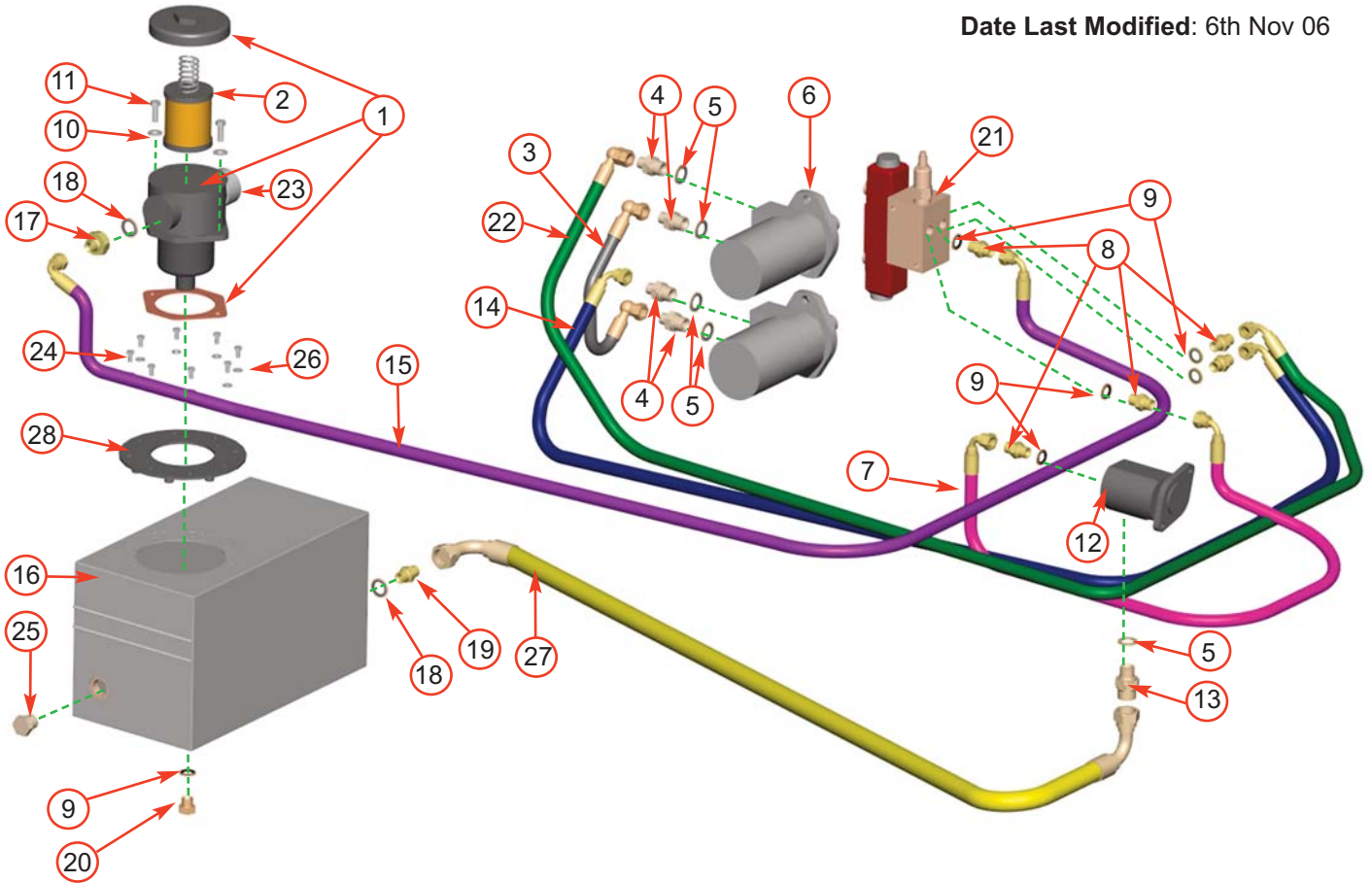

Item	Part No	Part Name	Q'ty	Item	Part No	Part Name	Q'ty
1	1434	Tank Top Filter Housing	1	15	4244	3/8" Hose, Hyd Filter to DCV	1
2	0100	Filter	1	16	1703	Hydraulic Oil Tank	1
3	0323	3/8" Hose, Top Motor to Btm Motor	1	17	0225	Adaptor 3/4" - 3/8"	1
4	0026	Adaptor mm 1/2" - 3/8" BSP	4	18	0152	Washer Dowty 3/4"	2
5	0398	Washer Dowty 1/2"	5	19	1766	Adapter 3/4" - 3/4" BSP	2
6	2982B	Hydraulic Motor	2	20	0211	3/8" BSP Plug	1
7	4243	3/8" Hose, Pump to DCV	1	21	1613	Directional Control Valve (DCV)	1
8	0161	Adaptor mm 3/8" - 3/8" BSP	5	22	17310	3/8" Hose, DCV to Top Motor	1
9	0396	Washer Dowty 3/8"	6	23	1067	Breather Filter	1
10	0711	M8 A Washer	2	24	1658	M6/12 Bolt	8
11	0350	M8/25 Bolt	2	25	4219	3/4" Tapered Blanking Plug	1
12	1660	Hydraulic Pump	1	26	0709	M6 C Washer	8
13	1583	Adaptor 1/2" - 3/4" BSP	1	27	1767	3/4" Hose, Hyd Tank to Pump	1
14	3094	3/8" Hose, Bottom Motor to DCV	1	28	1702F	Tank Top Plate	1

45 ROLLER BOX



TIMBERWOLF
TW 150DHB

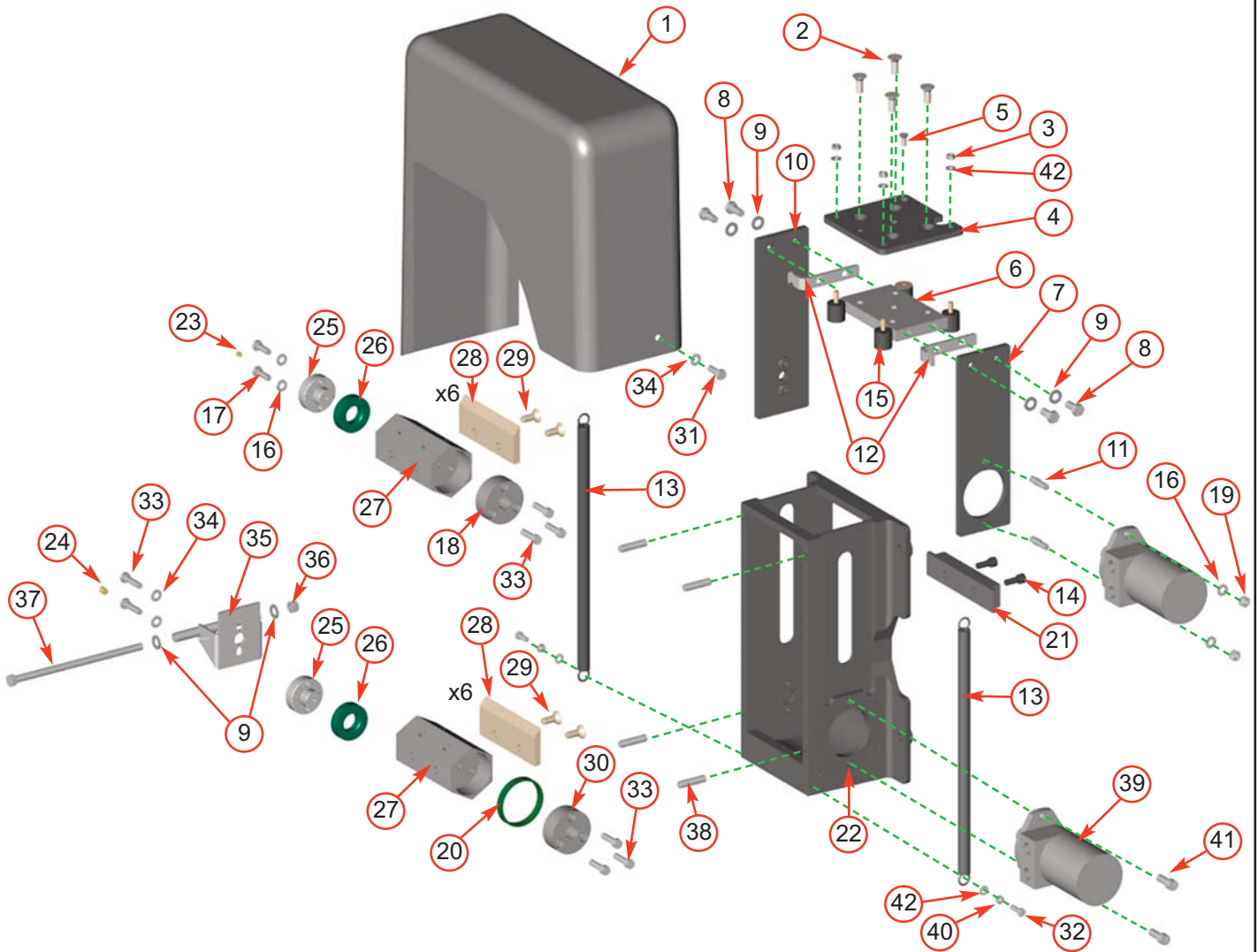

Date Last Modified: 21st June 12

Item	Part No	Part Name	Q'ty	Item	Part No	Part Name	Q'ty
1	0672	Rollerbox Cover	1	22	0228MS	Roller Box	1
2	4340	M12/50 Caphead	4	23	0985	Straight Grease Nipple	1
3	0481	M8 T Nyloc Nut	3	24	0986	45° Grease Nipple	1
4	18027M	Plate Top Damper Carrier	1	25	0055	Bearing Boss	2
5	P0000146	M8/18 Csk Screw	1	26	0788	Plastic Bush	2
6	1962MS	Block Top Damped	1	27	1362M	Roller Body	2
7	18024M	Drive Side Plate	1	28	0325M	Roller Blade	12
8	0429	M12/35 Bolt	4	29	0428	M12/30 Csk Soc.	24
9	0702	M12 A Washer	6	30	4100M	Spline 6B Retro Bottom	1
10	18025M	Non Drive Side Plate	1	31	0360	M10/25 Bolt	1
11	1162S	Motor Studs	2	32	0350	M8/25 Bolt	2
12	18028FS	Bracket Spring Hanger	2	33	4068	M10/40 Cap Head Bolt	8
13	18070	Roller Box Spring	2	34	0839	M10 C Washer	3
14	0305	M10/25 Caphead	2	35	0534FS	Cover Bracket	1
15	1768	AV Mount 30x30	4	36	0045	M12 T Nyloc Nut	1
16	0701	M10 A Washer	2	37	0319	M12/220 Bolt	1
17	0382	M10/30 Bolt	4	38	0356	Funnel Studs M12/50	4
18	1361M	Drive Spline	1	39	2982B	Motor	2
19	4345	M10 P Nyloc Nut	2	40	0476	M8 Plain Nut	2
20	2757	Bush Bearing Spline	1	41	1985	M12/30 Caphead	2
21	0103MH	Anvil	1	42	0711	M8 A Washer	5

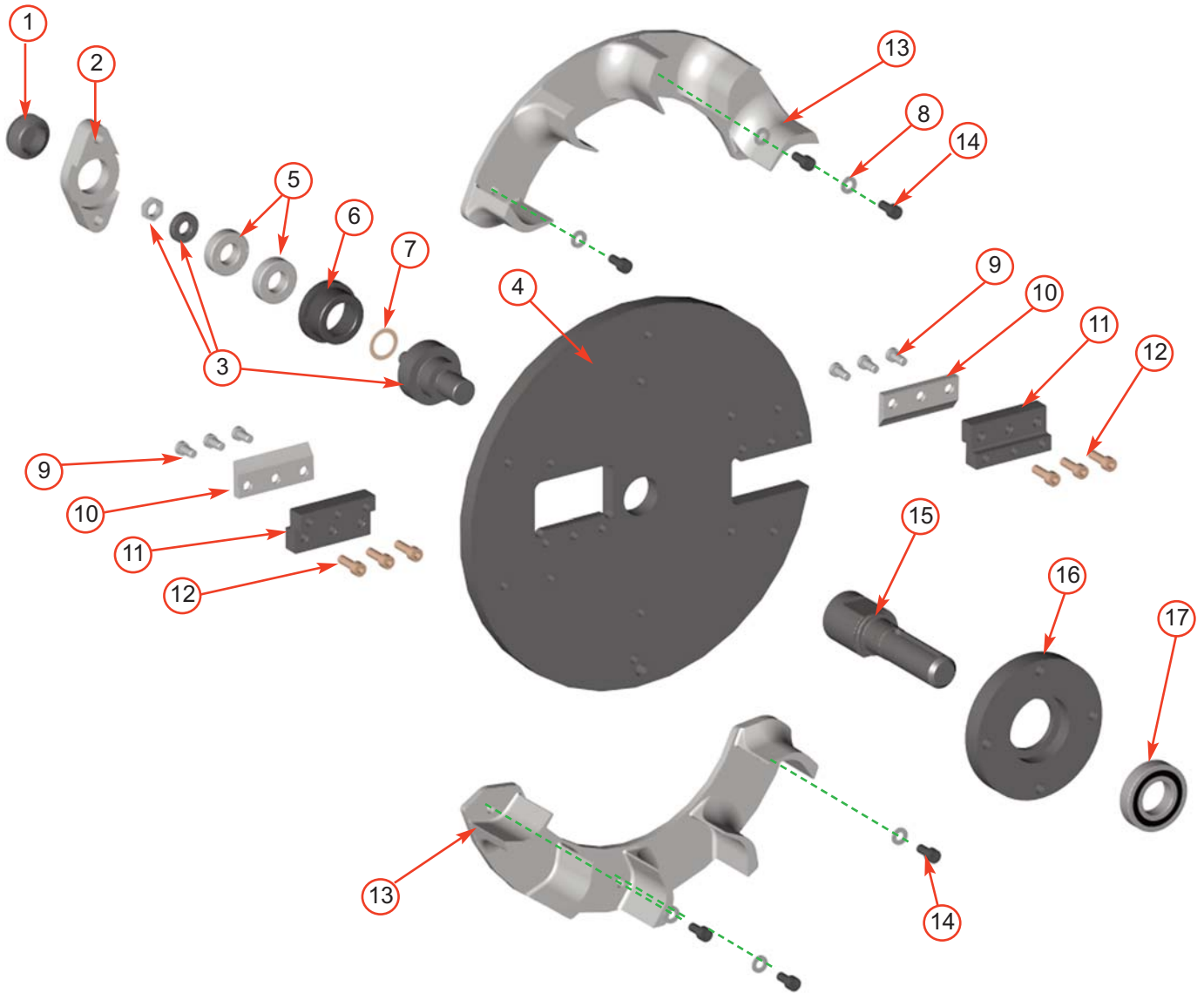

Date Last Modified: 10th Sept 09

Item	Part No	Part Name	Q'ty
1	0959	Plastic Cap	1
2	0884MS	Bearing Housing Front	1
3	18479K	Rotor Nose Shaft Kit	1
4	0880M	Rotor	1
5	0491	Bearing 6205	2
6	0883MCB	Bearing Cup	1
7	0796	20 Thou Shim	As Req'd
8	0701	M10 A Washer	6
9	0900	M10/20 Star Cap Screw	6

Item	Part No	Part Name	Q'ty
10	083MH	Cutter Blade 4"	2
11	18275M	Blade Pocket	2
12	0386	M10/30 Cap Screw	6
13	1571	Fan Section	2
14	0386	M10/30 Caphead	6
15	18912M	Rear Shaft	1
16	4063MCB	Bearing Housing Rear	1
17	0495	Bearing 6208	1

47 ROTOR HOUSING



TIMBERWOLF
TW 150DHB

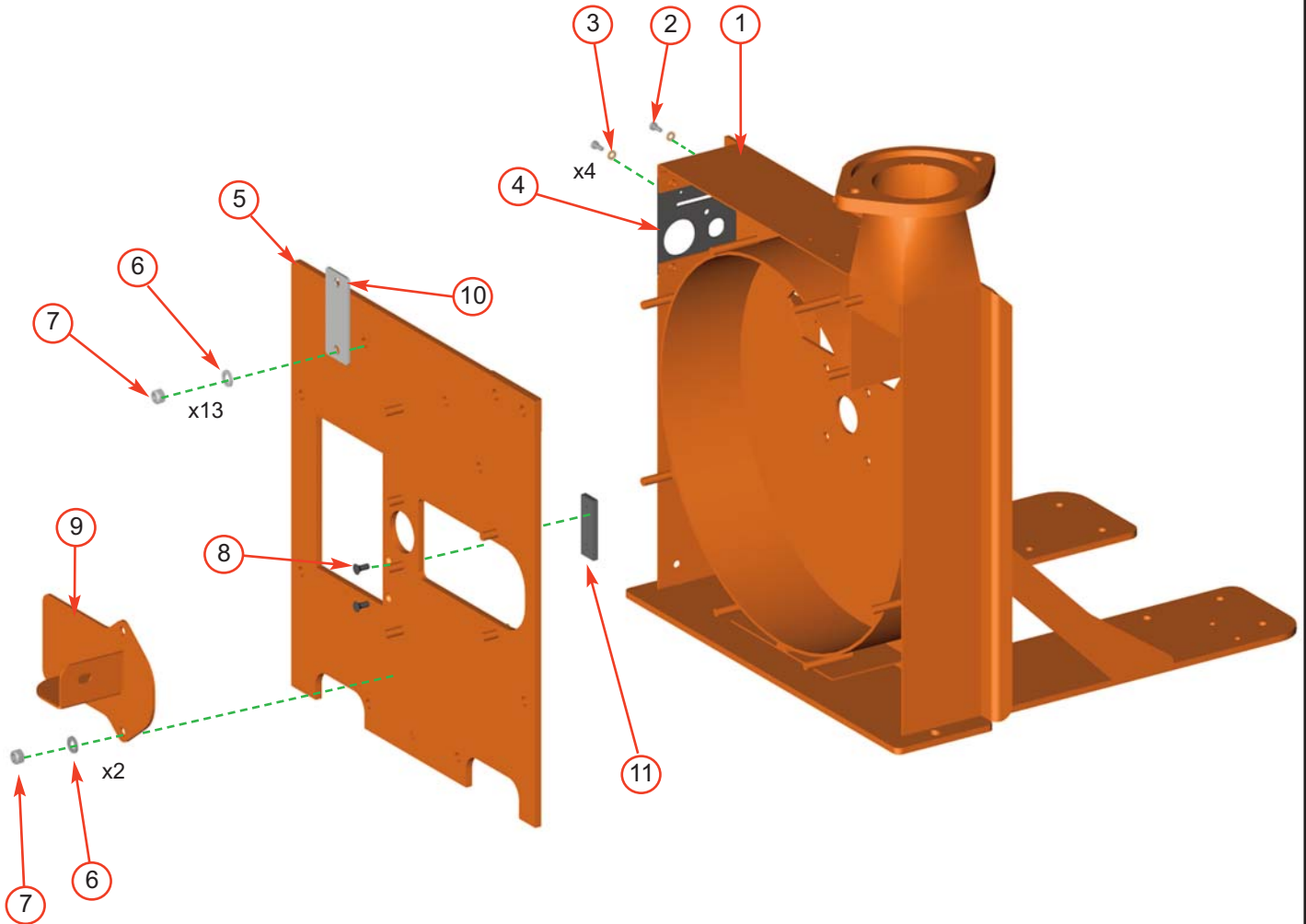

Date Last Modified: 24th Jan 08

Item	Part No	Part Name	Q'ty	Item	Part No	Part Name	Q'ty
1	18436FO	Rotor Housing	1	7	0045	M12 T Nyloc Nut	15
2	0438	M6/16 Pozi Pan	4	8	0355	M8/16 C/Sunk Bolt	2
3	0709	M6 C Washer	4	9	1268FO	Access Cover	1
4	1758S	Control Panel	1	10	18023PS	Guard Stand-Off Plate	1
5	1267FO	Front Plate	1	11	0101MH	Anvil Vertical	1
6	0702	M12 A Washer	15				



TIMBERWOLF V-BELT TENSIONING DATA TABLE

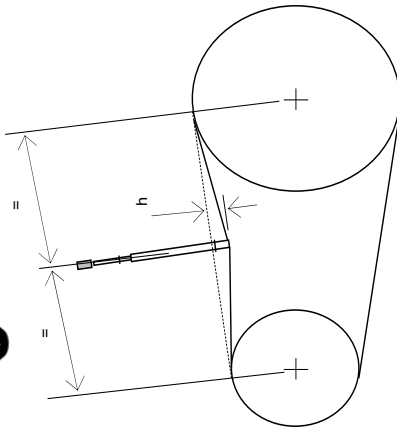

METHOD:

1. SET THE DEFLECTION DISTANCE ON THE LOWER SCALE OF THE TENSION GAUGE SO THAT THE UNDERSIDE OF THE 'O'-RING EQUALS THE 'h' VALUE GIVEN IN THE TABLE BELOW
2. ENSURE THAT THE DEFLECTION FORCE SCALE IS ZERO'D BY PUSHING THE UPPER 'O'-RING ALL THE WAY DOWN
3. PLACE THE TENSION GAUGE IN THE CENTRE OF THE BELT SPAN AS SHOWN IN THE DIAGRAM LEFT
4. PRESS DOWNWARDS ON THE RUBBER BUFFER, DEFLECTING THE BELT UNTIL THE UNDERSIDE OF THE LOWER O-RING IS LEVEL WITH THE BELT BEHIND (USE A STRAIGHT EDGE IF THERE IS ONLY 1 BELT)
5. TAKE THE READING FROM THE DEFLECTION SCALE OF THE TENSION METER (READ AT THE LOWER EDGE OF THE 'O'-RING) & COMPARE THIS VALUE WITH THAT GIVEN IN THE TABLE BELOW
6. TIGHTEN OR LOOSEN BELTS AS REQUIRED FOLLOWING PROCEDURE GIVEN IN THE OPERATOR'S MANUAL

TENSION GAUGES ARE AVAILABLE FROM TIMBERWOLF SPARES, QUOTING PART No. 18091

TIPS ON BELT TIGHTENING:

- A) THERE WILL NORMALLY BE A RAPID DROP IN TENSION DURING THE RUN-IN PERIOD FOR NEW BELTS. WHEN NEW BELTS ARE FITTED, CHECK THE TENSION EVERY 2-3 HOURS & ADJUST UNTIL THE TENSION REMAINS CONSTANT
- B) THE BEST TENSION FOR V-BELT DRIVES IS THE LOWEST TENSION AT WHICH THE BELTS DO NOT SLIP OR RATCHET UNDER THE HIGHEST LOAD CONDITION
- C) TOO MUCH TENSION SHORTENS BELT & BEARING LIFE
- D) TOO LITTLE TENSION WILL AFFECT THE PERFORMANCE OF YOUR MACHINE ESPECIALLY IN RESPECT OF NO-STRESS DEVICES
- E) ENSURE THAT BELT DRIVES ARE KEPT FREE OF ANY FOREIGN MATERIALS
- F) IF A BELT SLIPS - TIGHTEN IT!

TW MODEL No.:		13/75G	18/100G	125PH	150DHB	150VTR	190TDHB	190TFTIR 190TVGTR	350DHB(f)	PTO100	PTO150	S426 SHREDDER	S426TFTIR SHREDDER	PTO S426 SHREDDER	SX200PHB(c)
Rotor Belts	Belt Mfr / Type	Gates Super HC-MN SPA	Gates Super HC-MN SPA	Gates Super HC-MN SPA	Gates Super HC-MN SPA	Gates Super HC-MN SPA	Gates Super HC-MN SPA	Gates Super HC-MN SPA	Gates Super HC-MN SPA	Gates Super HC-MN SPA	Gates Super HC-MN SPA	Gates Super HC-MN SPA	Gates Super HC-MN SPA	Gates Super HC-MN SPA	Gates Super HC-MN SPA
	Belt Length	900.0	1060.0	1060.0	1060.0	1060.0	1232.0	1232.0	2530.0	900.0	900.0	2120.0	2120.0	1700.0	1272.0
	Belt deflection	h 4.0	h 4.0	h 3.5	h 4.0	h 4.0	h 4.0	h 4.0	h 8.0	h 4.0	h 4.0	h 8.0	h 8.0	h 6.0	h 5.0
Pump Belt	Force reading (Kgf)	New belt 3.4 - 3.6	New belt 3.1 - 3.3	New belt 3.3 - 3.6	New belt 4.3 - 4.5	New belt 4.3 - 4.5	New belt 3.9 - 4.1	New belt 3.9 - 4.1	New belt 3.3 - 3.6	New belt 3.3 - 3.5	New belt 3.8 - 4.0	New belt 3.3 - 3.5*	New belt 3.3 - 3.5	New belt 6.5 - 6.9	New belt 1.9 - 2.1
	Belt Mfr / Type	N/A	N/A	Gates Super HC-MN SPA	Gates Super HC-MN SPA	Gates Super HC-MN SPA	Gates Super HC-MN SPA	Gates Super HC-MN SPA	N/A	N/A	Gates Super HC-MN SPA	N/A	Gates Super HC-MN SPA	N/A	Gates Super HC-MN SPA
	Belt Length			925.0		900.0		925.0			925.0		1060.0		950.0
Rotor Belts	Belt deflection	h 4.0	h 4.0	h 4.0	h 4.0	h 4.0	h 4.0	h 4.0	h 4.0	h 4.0	h 4.0	h 4.0	h 4.0	h 4.0	h 4.0
	Force reading (Kgf)	New belt 3.0 - 3.2	New belt 2.8 - 3.0	New belt 2.8 - 3.1	New belt 3.7 - 4.0	New belt 3.7 - 4.0	New belt 3.4 - 3.6	New belt 3.4 - 3.6	New belt 2.9 - 3.1	New belt 2.9 - 3.0	New belt 3.3 - 3.5	New belt 2.9 - 3.1*	New belt 2.9 - 3.1	New belt 5.6 - 6.0	New belt 1.7 - 1.8
	Belt Mfr / Type	N/A	N/A	Gates Super HC-MN SPA	Gates Super HC-MN SPA	Gates Super HC-MN SPA	Gates Super HC-MN SPA	Gates Super HC-MN SPA	N/A	N/A	Gates Super HC-MN SPA	N/A	Gates Super HC-MN SPA	N/A	Gates Super HC-MN SPA
Pump Belt	Belt Length			925.0		900.0		925.0			925.0		1060.0		950.0
	Belt deflection	h 4.0	h 4.0	h 4.0	h 4.0	h 4.0	h 4.0	h 4.0	h 4.0	h 4.0	h 4.0	h 4.0	h 4.0	h 4.0	h 4.0
	Force reading (Kgf)	New belt 1.9 - 2.0	New belt 1.7 - 1.8	New belt 1.9 - 2.0	New belt 2.3 - 2.4	New belt 2.3 - 2.4	New belt 2.3 - 2.4	New belt 2.3 - 2.4	New belt 2.0 - 2.2	New belt 2.0 - 2.2	New belt 2.0 - 2.2	New belt 2.0 - 2.2	New belt 2.7 - 2.9	New belt 2.3 - 2.5	New belt 3.1 - 3.3
Rotor Belts	Belt Length			925.0		900.0		925.0			925.0		1060.0		950.0
	Belt deflection	h 4.0	h 4.0	h 4.0	h 4.0	h 4.0	h 4.0	h 4.0	h 4.0	h 4.0	h 4.0	h 4.0	h 4.0	h 4.0	h 4.0
	Force reading (Kgf)	New belt 1.7 - 1.8	New belt 1.7 - 1.8	New belt 1.9 - 2.0	New belt 2.3 - 2.4	New belt 2.3 - 2.4	New belt 2.3 - 2.4	New belt 2.3 - 2.4	New belt 2.0 - 2.2	New belt 2.0 - 2.2	New belt 2.0 - 2.2	New belt 2.0 - 2.2	New belt 2.7 - 2.9	New belt 2.3 - 2.5	New belt 3.1 - 3.3
Pump Belt	Belt Length			925.0		900.0		925.0			925.0		1060.0		950.0
	Belt deflection	h 4.0	h 4.0	h 4.0	h 4.0	h 4.0	h 4.0	h 4.0	h 4.0	h 4.0	h 4.0	h 4.0	h 4.0	h 4.0	h 4.0
	Force reading (Kgf)	New belt 1.7 - 1.8	New belt 1.7 - 1.8	New belt 1.9 - 2.0	New belt 2.3 - 2.4	New belt 2.3 - 2.4	New belt 2.3 - 2.4	New belt 2.3 - 2.4	New belt 2.0 - 2.2	New belt 2.0 - 2.2	New belt 2.0 - 2.2	New belt 2.0 - 2.2	New belt 2.7 - 2.9	New belt 2.3 - 2.5	New belt 3.1 - 3.3